

- This is a controlled product that may be subject to export licence. Consult your local Customs authority.
- Ceci est un produit contrôlé qui peut être soumis à licence d'exportation. Consultez les autorités douanières locales.
- Este es un producto controlado que podría estar sujeto a una licencia para su exportación. Consulte a su autoridad local de aduanas.
- Dieses Produkt unterliegt den Ausfuhrkontrollbestimmungen und benötigt ggf. eine Exportlizenz. Konsultieren Sie Ihre örtliche Zollbehörde.
- Questo è un prodotto controllato che potrebbe essere soggetto a licenza di esportazione. Consultate la vostra Dogana locale.

## *User Guide*

---

### ***Unidrive HS70***

### ***Unidrive HS71***

### ***Unidrive HS72***

---

Universal Variable Speed AC drive for High Speed induction and permanent magnet motors

Part Number: 0478-0231-01

Issue: 1



**Control Techniques™**

[www.controltechniques.com](http://www.controltechniques.com)

# Original Instructions

For the purposes of compliance with the EU Machinery Directive 2006/42/EC

## General information

The manufacturer accepts no liability for any consequences resulting from inappropriate, negligent or incorrect installation or adjustment of the optional operating parameters of the equipment or from mismatching the variable speed drive with the motor.

The contents of this guide are believed to be correct at the time of printing. In the interests of a commitment to a policy of continuous development and improvement, the manufacturer reserves the right to change the specification of the product or its performance, or the contents of the guide, without notice.

All rights reserved. No parts of this guide may be reproduced or transmitted in any form or by any means, electrical or mechanical including photocopying, recording or by an information storage or retrieval system, without permission in writing from the publisher.

## Drive firmware version

This product is supplied with the latest firmware version. If this drive is to be connected to an existing system or machine, all drive firmware versions should be verified to confirm the same functionality as drives of the same model already present. This may also apply to drives returned from a Control Techniques Service Centre or Repair Centre. If there is any doubt please contact the supplier of the product.

The firmware version of the drive can be checked by looking at Pr **11.029**.

The firmware version of the Ethernet interface can be checked by looking at Pr **24.002**

## Environmental statement

Control Techniques is committed to minimising the environmental impacts of its manufacturing operations and of its products throughout their life cycle. To this end, we operate an Environmental Management System (EMS) which is certified to the International Standard ISO 14001. Further information on the EMS, our Environmental Policy and other relevant information is available on request, or can be found at [www.greendrives.com](http://www.greendrives.com).

The electronic variable-speed drives manufactured by Control Techniques have the potential to save energy and (through increased machine/process efficiency) reduce raw material consumption and scrap throughout their long working lifetime. In typical applications, these positive environmental effects far outweigh the negative impacts of product manufacture and end-of-life disposal.

Nevertheless, when the products eventually reach the end of their useful life, they must not be discarded but should instead be recycled by a specialist recycler of electronic equipment. Recyclers will find the products easy to dismantle into their major component parts for efficient recycling. Many parts snap together and can be separated without the use of tools, while other parts are secured with conventional fasteners. Virtually all parts of the product are suitable for recycling.

Product packaging is of good quality and can be re-used. Large products are packed in wooden crates, while smaller products come in strong cardboard cartons which themselves have a high recycled fibre content. If not re-used, these containers can be recycled. Polythene, used on the protective film and bags for wrapping product, can be recycled in the same way. Control Techniques' packaging strategy prefers easily-recyclable materials of low environmental impact, and regular reviews identify opportunities for improvement.

When preparing to recycle or dispose of any product or packaging, please observe local legislation and best practice.

## REACH legislation

EC Regulation 1907/2006 on the Registration, Evaluation, Authorisation and restriction of Chemicals (REACH) requires the supplier of an article to inform the recipient if it contains more than a specified proportion of any substance which is considered by the European Chemicals Agency (ECHA) to be a Substance of Very High Concern (SVHC) and is therefore listed by them as a candidate for compulsory authorisation.

For current information on how this requirement applies in relation to specific Control Techniques products, please approach your usual contact in the first instance. Control Techniques position statement can be viewed at:

<http://www.controltechniques.com/REACH>

Copyright © February 2015 Control Techniques Ltd

Issue Number: 1

Drive Firmware: 02.09.01 onwards

Ethernet Firmware: 01.04.00.00 onwards

*For patent and intellectual property related information please go to: [www.ctpatents.info](http://www.ctpatents.info)*

# How to use this guide

This user guide provides complete information for installing and operating the drive from start to finish.

The information is in logical order, taking the reader from receiving the drive through to fine tuning the performance.

## NOTE

There are specific safety warnings throughout this guide, located in the relevant sections. In addition, Chapter 1 *Safety information* contains general safety information. It is essential that the warnings are observed and the information considered when working with or designing a system using the drive.

This map of the user guide helps to find the right sections for the task you wish to complete, but for specific information, refer to *Contents* on page 4:

	Quick Start / bench testing	Familiarisation	System design	Programming and commissioning	Troubleshooting
1 Safety information	●	●	●	●	●
2 Product information		●	●		
3 Electrical installation			●		
4 Getting started		●	●		
5 Basic parameters		●	●	●	
6 Running the motor	●	●	●	●	
7 Optimization			●	●	
8 NV media card operation			●	●	
9 Onboard PLC			●	●	
10 Advanced parameters			●	●	
11 Technical data		●	●	●	
12 Diagnostics					●
13 UL listing information			●	●	



# Contents

<b>1</b>	<b>Safety information .....</b>	<b>6</b>	<b>Optimization .....</b>	<b>77</b>	
1.1	Warnings, Cautions and Notes.....	6	7.1	Motor map parameters .....	77
1.2	Electrical safety - general warning .....	6	7.2	Maximum motor rated current .....	86
1.3	System design and safety of personnel .....	6	7.3	Current limits .....	86
1.4	Environmental limits.....	6	7.4	Motor thermal protection.....	86
1.5	Access.....	6	7.5	Switching frequency .....	87
1.6	Fire protection.....	6	7.6	High speed operation.....	87
1.7	Compliance with regulations.....	6	<b>8</b>	<b>NV Media Card Operation.....</b>	<b>89</b>
1.8	Motor .....	6	8.1	Introduction .....	89
1.9	Mechanical brake control .....	6	8.2	NV Media Card support .....	89
1.10	Adjusting parameters .....	6	8.3	Transferring data .....	90
1.11	Electrical installation .....	7	8.4	Data block header information .....	91
<b>2</b>	<b>Product information.....</b>	<b>8</b>	8.5	NV Media Card parameters .....	92
2.1	Introduction.....	8	8.6	NV Media Card trips .....	93
2.2	Model number.....	8	<b>9</b>	<b>Onboard PLC.....</b>	<b>94</b>
2.3	Ratings .....	9	9.1	Onboard PLC and Machine Control Studio.....	94
2.4	Operating modes .....	10	9.2	Benefits.....	94
2.5	Compatible position feedback devices.....	11	9.3	Features.....	94
2.6	Nameplate description .....	12	9.4	Onboard PLC parameters.....	95
2.7	Options .....	13	9.5	Onboard PLC trips.....	95
<b>3</b>	<b>Electrical installation .....</b>	<b>15</b>	<b>10</b>	<b>Advanced parameters .....</b>	<b>96</b>
3.1	Communications connections.....	15	10.1	Menu 1: Frequency / speed reference.....	108
3.2	Control connections .....	16	10.2	Menu 2: Ramps .....	112
3.3	Position feedback connections .....	23	10.3	Menu 3: Frequency slaving, speed feedback and speed control .....	115
3.4	SAFE TORQUE OFF (STO).....	29	10.4	Menu 4: Torque and current control .....	126
<b>4</b>	<b>Getting started .....</b>	<b>32</b>	10.5	Menu 5: Motor control.....	130
4.1	Understanding the display.....	32	10.6	Menu 6: Sequencer and clock.....	137
4.2	Keypad operation.....	32	10.7	Menu 7: Analog I/O / Temperature Monitoring .	141
4.3	Menu structure.....	34	10.8	Menu 8: Digital I/O.....	144
4.4	Menu 0 .....	35	10.9	Menu 9: Programmable logic, motorized pot, binary sum and timers.....	150
4.5	Advanced menus .....	35	10.10	Menu 10: Status and trips.....	156
4.6	Changing the operating mode .....	37	10.11	Menu 11: General drive set-up.....	158
4.7	Saving parameters.....	37	10.12	Menu 12: Threshold detectors, variable selectors and brake control function.....	160
4.8	Restoring parameter defaults .....	37	10.13	Menu 13: Standard motion controller .....	168
4.9	Parameter access level and security .....	37	10.14	Menu 14: User PID controller.....	172
4.10	Displaying parameters with non-default values only.....	38	10.15	Menus 15, 16 and 17: Option module set-up .....	176
4.11	Displaying destination parameters only .....	38	10.16	Menu 18: Application menu 1.....	177
4.12	Communications .....	38	10.17	Menu 19: Application menu 2.....	177
<b>5</b>	<b>Basic parameters .....</b>	<b>41</b>	10.18	Menu 20: Application menu 3.....	177
5.1	Menu 0: Basic parameters .....	41	10.19	Menu 21: Second motor parameters .....	178
5.2	Parameter descriptions .....	48	10.20	Menu 22: Additional Menu 0 set-up.....	180
5.3	Full descriptions .....	50	10.21	Menu 24: Ethernet status and monitoring (Unidrive HS70 / HS72) .....	181
<b>6</b>	<b>Running the motor.....</b>	<b>61</b>	<b>11</b>	<b>Technical data.....</b>	<b>191</b>
6.1	Quick start connections.....	61	11.1	Drive technical data.....	191
6.2	Changing the operating mode .....	61			
6.3	Quick start commissioning / start-up.....	66			
6.4	Setting up a feedback device .....	70			
6.5	Encoder Simulation Output Set-up .....	74			

<b>12</b>	<b>Diagnostics .....</b>	<b>194</b>
12.1	Status modes (Keypad and LED status) .....	194
12.2	Trip indications.....	194
12.3	Identifying a trip / trip source .....	195
12.4	Trips, Sub-trip numbers.....	196
12.5	Internal / Hardware trips.....	222
12.6	Alarm indications.....	223
12.7	Status indications.....	223
12.8	Programming error indications.....	223
12.9	Displaying the trip history .....	224
12.10	Behaviour of the drive when tripped .....	224
<b>13</b>	<b>UL listing information.....</b>	<b>225</b>
13.1	General.....	225
13.2	Mounting.....	225
13.3	Environment .....	225
13.4	Electrical installation.....	225
13.5	UL listed accessories .....	225
13.6	Motor overload protection.....	225
13.7	Motor overspeed protection.....	225
13.8	Thermal memory retention .....	225
13.9	Electrical Ratings .....	225
13.10	cUL requirements for 575 V frame size 7 and 8	225

# 1 Safety information

## 1.1 Warnings, Cautions and Notes



A Warning contains information which is essential for avoiding a safety hazard.

**WARNING**



A Caution contains information which is necessary for avoiding a risk of damage to the product or other equipment.

**CAUTION**

### NOTE

A Note contains information which helps to ensure correct operation of the product.

## 1.2 Electrical safety - general warning

The voltages used in the drive can cause severe electrical shock and/or burns, and could be lethal. Extreme care is necessary at all times when working with or adjacent to the drive.

Specific warnings are given at the relevant places in this User Guide.

## 1.3 System design and safety of personnel

The drive is intended as a component for professional incorporation into complete equipment or a system. If installed incorrectly, the drive may present a safety hazard.

The drive uses high voltages and currents, carries a high level of stored electrical energy, and is used to control equipment which can cause injury.

Close attention is required to the electrical installation and the system design to avoid hazards either in normal operation or in the event of equipment malfunction. System design, installation, commissioning/start-up and maintenance must be carried out by personnel who have the necessary training and experience. They must read this safety information and this User Guide carefully.

The STOP and Safe Torque Off functions of the drive do not isolate dangerous voltages from the output of the drive or from any external option unit. The supply must be disconnected by an approved electrical isolation device before gaining access to the electrical connections.

**With the sole exception of the Safe Torque Off function, none of the drive functions must be used to ensure safety of personnel, i.e. they must not be used for safety-related functions.**

Careful consideration must be given to the functions of the drive which might result in a hazard, either through their intended behavior or through incorrect operation due to a fault. In any application where a malfunction of the drive or its control system could lead to or allow damage, loss or injury, a risk analysis must be carried out, and where necessary, further measures taken to reduce the risk - for example, an over-speed protection device in case of failure of the speed control, or a fail-safe mechanical brake in case of loss of motor braking.

The Safe Torque Off function may be used in a safety-related application. The system designer is responsible for ensuring that the complete system is safe and designed correctly according to the relevant safety standards.

## 1.4 Environmental limits

Instructions in this User Guide regarding transport, storage, installation and use of the drive must be complied with, including the specified environmental limits. Drives must not be subjected to excessive physical force.

## 1.5 Access

Drive access must be restricted to authorized personnel only. Safety regulations which apply at the place of use must be complied with.

## 1.6 Fire protection

The drive enclosure is not classified as a fire enclosure. A separate fire enclosure must be provided. For further information, refer to the *Drive Installation Guide*.

## 1.7 Compliance with regulations

The installer is responsible for complying with all relevant regulations, such as national wiring regulations, accident prevention regulations and electromagnetic compatibility (EMC) regulations. Particular attention must be given to the cross-sectional areas of conductors, the selection of fuses or other protection, and protective ground (earth) connections.

This User Guide contains instruction for achieving compliance with specific EMC standards.

Within the European Union, all machinery in which this product is used must comply with the following directives:

- 2006/42/EC Safety of machinery.
- 2004/108/EC: Electromagnetic Compatibility.

## 1.8 Motor

Ensure the motor is installed in accordance with the manufacturer's recommendations. Ensure the motor shaft is not exposed.

Standard squirrel cage induction motors are designed for single speed operation. If it is intended to use the capability of the drive to run a motor at speeds above its designed maximum, it is strongly recommended that the manufacturer is consulted first.

Low speeds may cause the motor to overheat because the cooling fan becomes less effective. The motor should be installed with a protection thermistor. If necessary, an electric forced vent fan should be used.

The values of the motor parameters set in the drive affect the protection of the motor. The default values in the drive should not be relied upon.

It is essential that the correct value is entered in Pr **00.046** motor rated current. This affects the thermal protection of the motor.

## 1.9 Mechanical brake control

The brake control functions are provided to allow well co-ordinated operation of an external brake with the drive. While both hardware and software are designed to high standards of quality and robustness, they are not intended for use as safety functions, i.e. where a fault or failure would result in a risk of injury. In any application where the incorrect operation of the brake release mechanism could result in injury, independent protection devices of proven integrity must also be incorporated.

## 1.10 Adjusting parameters

Some parameters have a profound effect on the operation of the drive. They must not be altered without careful consideration of the impact on the controlled system. Measures must be taken to prevent unwanted changes due to error or tampering.

## 1.11 Electrical installation

### 1.11.1 Electric shock risk

The voltages present in the following locations can cause severe electric shock and may be lethal:

AC supply cables and connections

Output cables and connections

Many internal parts of the drive, and external option units

Unless otherwise indicated, control terminals are single insulated and must not be touched.

### 1.11.2 Stored charge

The drive contains capacitors that remain charged to a potentially lethal voltage after the AC supply has been disconnected. If the drive has been energized, the AC supply must be isolated at least ten minutes before work may continue.

## 2 Product information

### 2.1 Introduction

#### Universal AC and servo drive

This product family consists of *Unidrive HS70*, *Unidrive HS71* and *Unidrive HS72*, these deliver maximum machine performance.

#### Common features (Unidrive HS70, HS71 and HS72)

- Universal high performance open and closed loop control for induction, servo, permanent magnet and linear motors
- Automation and motion option module for direct migration of SyPTPro / SM-Applications programs
- Onboard IEC 61131-3 programmable automation and motion control
- Flexibility with speed and position measurement, supporting multiple devices and all common interfaces
- NV Media Card for parameter copying and data storage

#### Optional features (Unidrive HS70, HS71 and HS72)

- Select up to three option modules including programmable automation and motion control.

#### Unidrive HS70

- Ethernet fieldbus communications
- Single channel Safe Torque Off (STO) input

#### Unidrive HS71

- Provides a direct replacement / upgrade for Unidrive SP
- 485 serial communications interface
- Single channel Safe Torque Off (STO) input

#### Unidrive HS72

- Ethernet fieldbus communications
- Dual channel Safe Torque Off (STO) input

### 2.2 Model number

The way in which the model numbers for the *Unidrive HS70* range are formed is illustrated below:

Figure 2-1 Model number

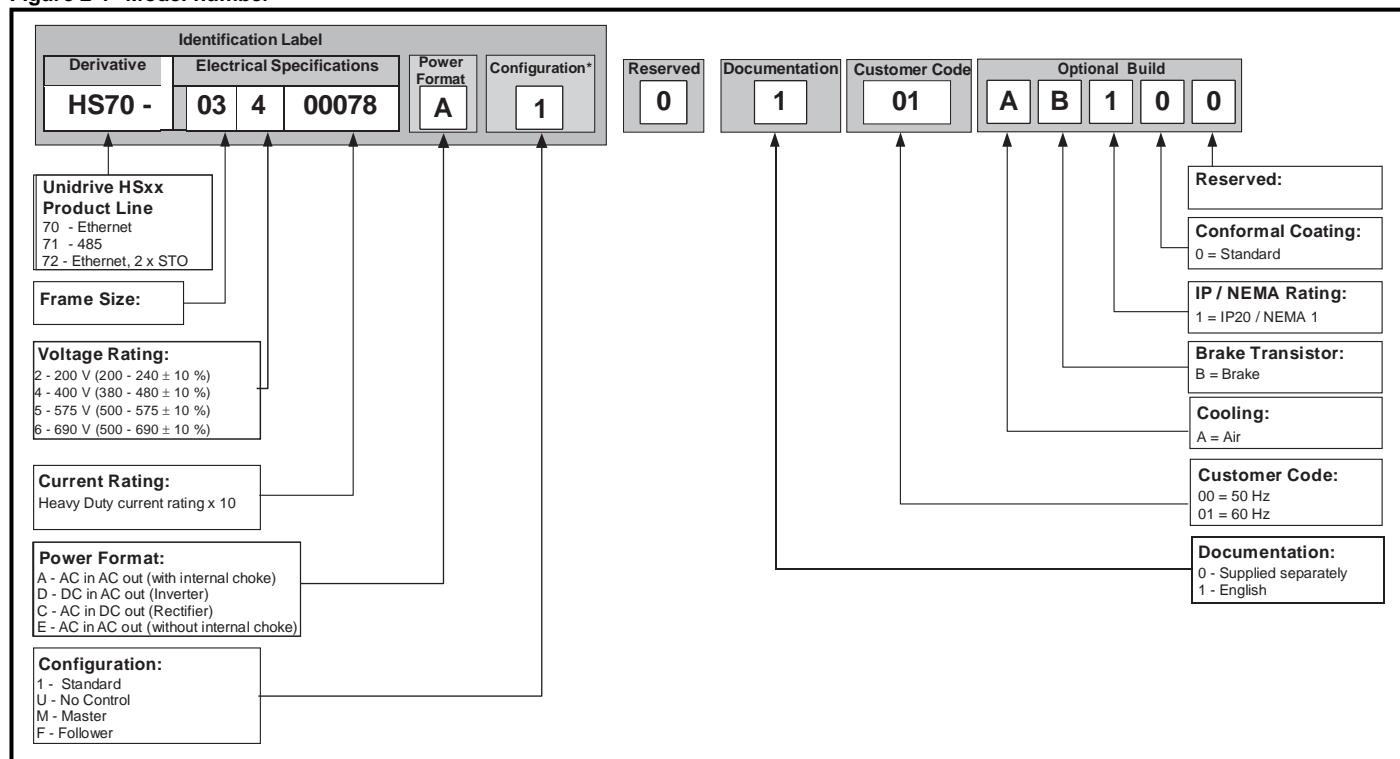

\* Only shown on Frame size 9E and 10 identification label.

#### NOTE

For simplicity a Frame 9 drive with no internal choke (i.e. model 09xxxxxE) is referred to as a Frame 9E and a Frame 9 drive with an internal choke (i.e. model 09xxxxxA) is referred to as a Frame 9A. Any reference to Frame 9 is applicable to both sizes 9E and 9A.

## 2.3 Ratings

The drive is dual rated.  
 The setting of the motor rated current determines which rating applies - Heavy Duty or Normal Duty.  
 The two ratings are compatible with motors designed to IEC60034.  
 The graph aside illustrates the difference between Normal Duty and Heavy Duty with respect to continuous current rating and short term overload limits.

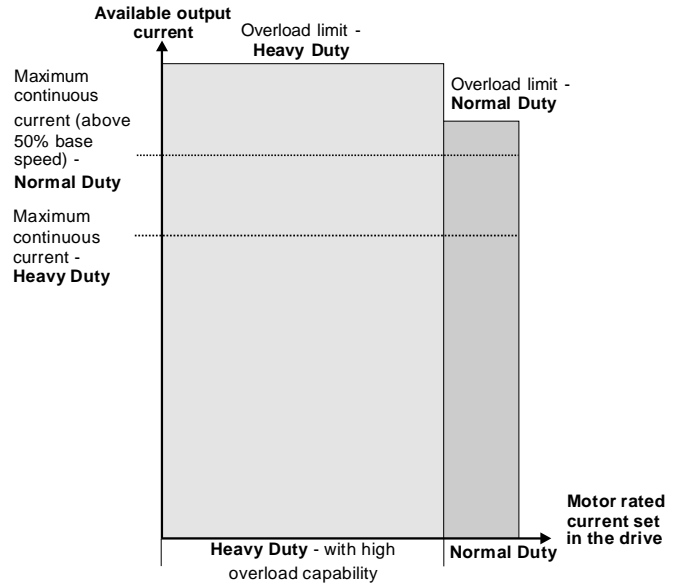

### Normal Duty

For applications which use Self ventilated (TENV/TEFC) induction motors and require a low overload capability, and full torque at low speeds is not required (e.g. fans, pumps).  
 Self ventilated (TENV/TEFC) induction motors require increased protection against overload due to the reduced cooling effect of the fan at low speed. To provide the correct level of protection the I<sup>2</sup>t software operates at a level which is speed dependent. This is illustrated in the graph below.

#### NOTE

The speed at which the low speed protection takes effect can be changed by the setting of *Low Speed Thermal Protection Mode* (04.025). The protection starts when the motor speed is below 15 % of base speed when Pr 04.025 = 0 (default) and below 50 % when Pr 04.025 = 1.

### Heavy Duty (default)

For constant torque applications or applications which require a high overload capability, or full torque is required at low speeds (e.g. winders, hoists).  
 The thermal protection is set to protect force ventilated induction motors and permanent magnet servo motors by default.

#### NOTE

If the application uses a self ventilated (TENV/TEFC) induction motor and increased thermal protection is required for speeds below 50 % base speed, then this can be enabled by setting *Low Speed Thermal Protection Mode* (04.025) = 1.

### Operation of motor I<sup>2</sup>t protection

Motor I<sup>2</sup>t protection is fixed as shown below and is compatible with:

- Self ventilated (TENV/TEFC) induction motors

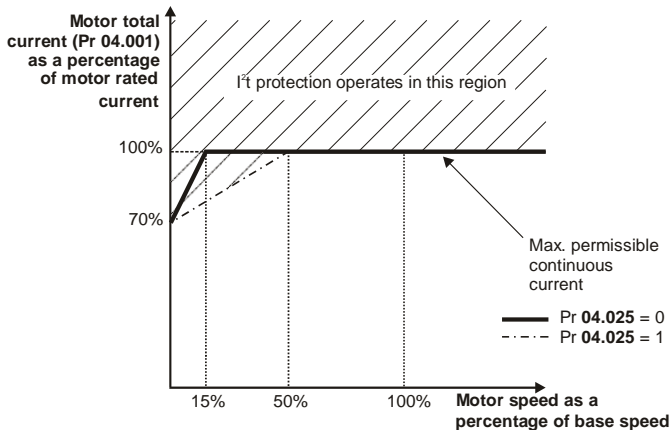

Motor I<sup>2</sup>t protection defaults to be compatible with:

- Forced ventilation induction motors
- Permanent magnet servo motors

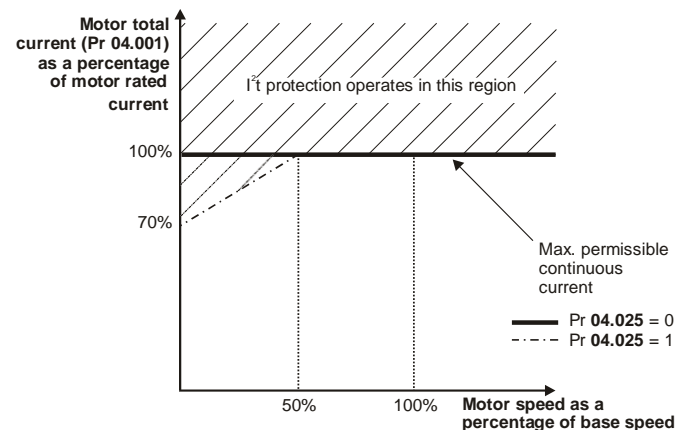

### 2.3.1 Typical short term overload limits

The maximum percentage overload limit changes depending on the selected motor. Variations in motor rated current, motor power factor and motor leakage inductance all result in changes in the maximum possible overload. The exact value for a specific motor can be calculated using the equations detailed in Menu 4 in the *Parameter Reference Guide*.

Typical values are shown in the table below for RFC (RFC-A or RFC-S) and open loop (OL) modes:

**Table 2-1 Typical overload limits**

Operating mode	RFC from cold	RFC from 100 %	Open loop from cold	Open loop from 100 %
Normal Duty overload with motor rated current = drive rated current	110 % for 165 s	110 % for 9 s	110 % for 165 s	110 % for 9 s
Heavy Duty overload with motor rated current = drive rated current (size 8 and below)	200 % for 28 s	200 % for 3 s	150 % for 60 s	150 % for 7 s
Heavy Duty overload with motor rated current = drive rated current (size 9E and 10)	170 % for 42 s	170 % for 5 s	150 % for 60 s	150 % for 7 s

Generally the drive rated current is higher than the matching motor rated current allowing a higher level of overload than the default setting.

The time allowed in the overload region is proportionally reduced at very low output frequency on some drive ratings.

#### NOTE

The maximum overload level which can be attained is independent of the speed.

## 2.4 Operating modes

The drive is designed to operate in any of the following modes:

1. Open loop mode
  - Open loop vector mode
  - Fixed V/F mode (V/Hz)
  - Quadratic V/F mode (V/Hz)
2. RFC - A
  - With position feedback sensor
  - Without position feedback sensor (Sensorless)
3. RFC - S
  - With position feedback sensor
  - Without position feedback sensor (Sensorless)

### 2.4.1 Open loop mode

The drive applies power to the motor at frequencies varied by the user. The motor speed is a result of the output frequency of the drive and slip due to the mechanical load. The drive can improve the speed control of the motor by applying slip compensation. The performance at low speed depends on whether V/F mode or open loop vector mode is selected.

#### Open loop vector mode

The voltage applied to the motor is directly proportional to the frequency except at low speed where the drive uses motor parameters to apply the correct voltage to keep the flux constant under varying load conditions.

Typically 100 % torque is available down to 1 Hz for a 50 Hz motor.

#### Fixed V/F mode

The voltage applied to the motor is directly proportional to the frequency except at low speed where a voltage boost is provided which is set by the user. This mode can be used for multi-motor applications.

Typically 100 % torque is available down to 4 Hz for a 50 Hz motor.

#### Quadratic V/F mode

The voltage applied to the motor is directly proportional to the square of the frequency except at low speed where a voltage boost is provided which is set by the user. This mode can be used for running fan or pump applications with quadratic load characteristics or for multi-motor applications. This mode is not suitable for applications requiring a high starting torque.

### 2.4.2 RFC-A mode

Rotor Flux Control for Asynchronous (induction) motors (**RFC-A**) encompasses closed loop vector control with a position feedback device

#### With position feedback

For use with induction motors with a feedback device installed. The drive directly controls the speed of the motor using the feedback device to ensure the rotor speed exactly as demanded. Motor flux is accurately controlled at all times to provide full torque all the way down to zero speed.

#### Without position feedback (Sensorless)

Sensorless mode provides closed loop control without the need for position feedback by using current, voltages and key motor parameters to estimate the motor speed. It can eliminate instability traditionally associated with open loop control such as operating large motors with light loads at low frequencies.

### 2.4.3 RFC- S

Rotor Flux Control for Synchronous (permanent magnet brushless) motors (**RFC-S**) provides closed loop control with position feedback device.

#### With position feedback

For use with permanent magnet brushless motors with a feedback device installed.

The drive directly controls the speed of the motor using the feedback device to ensure the rotor speed is exactly as demanded. Flux control is not required because the motor is self excited by the permanent magnets which form part of the rotor.

Absolute position information is required from the feedback device to ensure the output voltage is accurately matched to the back EMF of the motor. Full torque is available all the way down to zero speed.

## 2.5 Compatible position feedback devices

**Table 2-2 Supported feedback devices**

Encoder type	Pr 3.038 setting
Quadrature incremental encoders with or without marker pulse	AB (0)
Quadrature incremental encoders with UVW commutation signals for absolute position for permanent magnet motors with or without marker pulse	AB Servo (3)
Forward / reverse incremental encoders with or without marker pulse	FR (2)
Forward / reverse incremental encoders with UVW commutation signals for absolute position for permanent magnet motors with or without marker pulse	FR Servo (5)
Frequency and direction incremental encoders with or without marker pulse	FD (1)
Frequency and direction incremental encoders with UVW commutation signals for absolute position for permanent magnet motors with or without marker pulse	FD Servo (4)
Sincos incremental encoders	SC (6)
Sincos incremental with commutation signals	SC Servo (12)
Heidenhain sincos encoders with EnDat comms for absolute position	SC EnDat (9)
Stegmann sincos encoders with Hiperface comms for absolute position	SC Hiperface (7)
Sincos encoders with SSI comms for absolute position	SC SSI (11)
Sincos incremental with absolute position from single sin and cosine signals	SC SC (15)
SSI encoders (Gray code or binary)	SSI (10)
EnDat communication only encoders	EnDat (8)
BiSS communication only encoders* (not currently supported)	BiSS (13)
Resolver	Resolver (14)
UVW commutation only encoders** (not currently supported)	Commutation only (16)

\* Only BiSS type C encoders are supported.

\*\* This feedback device provides very low resolution feedback and should not be used for applications requiring a high level of performance.

## 2.6 Nameplate description

See *Drive Installation Guide* for location of rating labels.

Figure 2-2 Typical drive rating labels

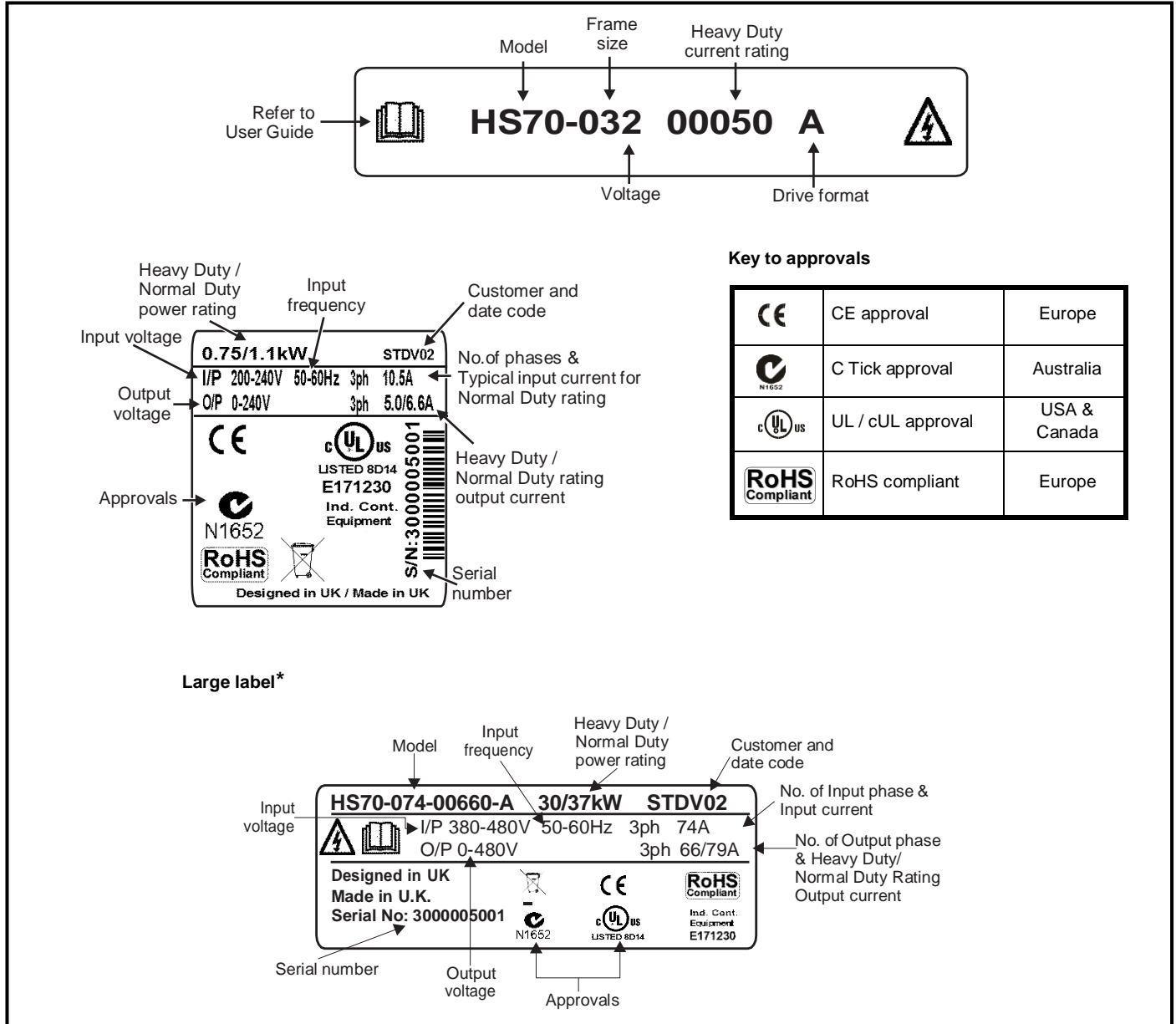

\* This label is only applicable to Size 7 and above.

Refer to Figure 2-1 *Model number* on page 8 for further information relating to the labels.

## 2.7 Options

Figure 2-3 Options available with the drive

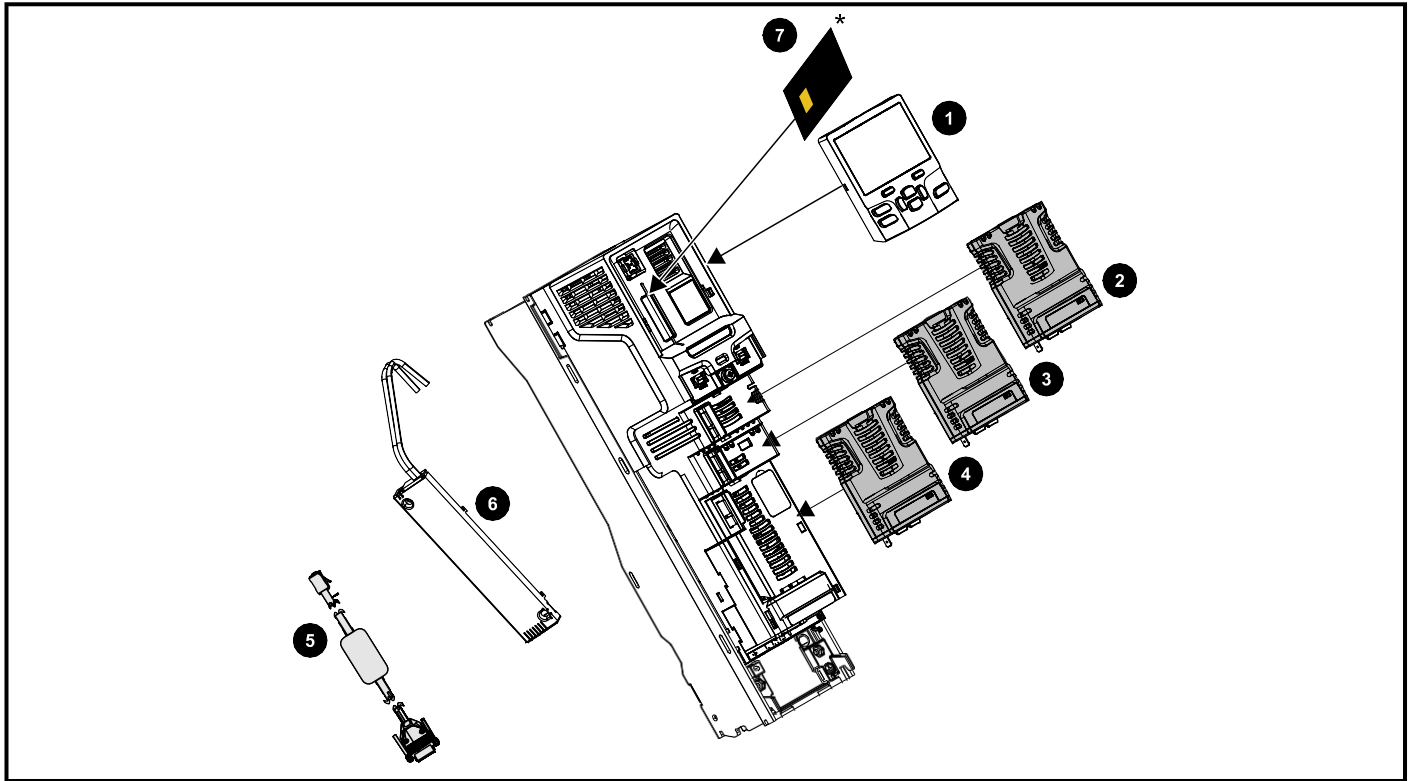

- |                         |                                                             |
|-------------------------|-------------------------------------------------------------|
| 1. Keypad               | 6. Internal braking resistor (available on size 3, 4 and 5) |
| 2. Option module slot 1 | 7. NV media card                                            |
| 3. Option module slot 2 |                                                             |
| 4. Option module slot 3 |                                                             |
| 5. CT Comms cable       |                                                             |





\* For further information, refer to Chapter 8 *NV Media Card Operation* on page 89.

Unidrive HS option modules come in two different formats, a standard option module and a large option module. All standard option modules are color-coded in order to make identification easy, whereas the larger option module is black. All modules have an identification label on top of the module. Standard option modules can be installed to any of the available option slots on the drive, whereas the large option modules can only be installed to option slot 3. The following tables shows the color-code key and gives further details on their function.

Table 2-3 Option module identification

Type	Option module	Color	Name	Further Details
Feedback		N/A	15-way D-type converter	<b>Drive encoder input converter</b> Provides screw terminal interface for encoder wiring and spade terminal for shield
		N/A	Single ended encoder interface (15V or 24V)	<b>Single ended encoder interface</b> Provides an interface for single ended ABZ encoder signals, such as those from hall effect sensors. 15 V and 24 V versions are available
Fieldbus		N/A	KI-485 Adaptor	<b>485 Comms Adaptor</b> 485 Comms adaptor provides 485 communication interface. This adaptor supports 115 k Baud, node addresses between 1 to 16 and 8 1 NP M serial mode.
		Purple	SI-PROFIBUS	<b>Profibus option</b> PROFIBUS adapter for communications with the drive
		Medium Grey	SI-DeviceNet	<b>DeviceNet option</b> DeviceNet adapter for communications with the drive
		Light Grey	SI-CANopen	<b>CANopen option</b> CANopen adapter for communications with the drive



**Table 2-3 Option module identification**

Type	Option module	Color	Name	Further Details
Automation (I/O expansion)		Orange	SI-I/O	<b>Extended I/O</b> Increases the I/O capability by adding the following combinations: <ul style="list-style-type: none"> <li>• Digital I/O</li> <li>• Digital Inputs</li> <li>• Analog Inputs (differential or single ended)</li> <li>• Analog Output</li> <li>• Relays</li> </ul>
Automation (Applications)		Moss Green	MCi200	<b>Machine Control Studio Compatible Applications Processor</b> 2nd processor for running pre-defined and/or customer created application software.
		Moss Green	MCi210	<b>Machine Control Studio Compatible Applications Processor (with Ethernet communications)</b> 2nd processor for running pre-defined and/or customer created application software with Ethernet communications.
		Black	SI-Applications Plus	<b>SyPTPro Compatible Applications Processor (with CTNet)</b> 2nd processor for running pre-defined and/or customer created application software with CTNet support (can only be used on Slot 3).
	SI-Register		<b>SyPTPro Compatible Applications Processor</b> 2nd processor for running position capture functionality with CTNet support (can only be used on Slot 3).	

**Table 2-4 Keypad identification**

Type	Keypad	Name	Further Details
Keypad		KI-Keypad	<b>LCD keypad option</b> Keypad with a LCD display
		KI-Keypad RTC	<b>LCD keypad option</b> Keypad with a LCD display and real time clock

**Table 2-5 Additional options**

Type	Option	Name	Further Details
Back-up		SD Card Adaptor	<b>SD Card Adaptor</b> Allows the drive to use an SD card for drive back-up
		SMARTCARD	<b>SMARTCARD</b> Used for parameter back-up with the drive

## 3 Electrical installation

Many cable management features have been incorporated into the product and accessories, this chapter shows how to optimize them. Key features include:

- SAFE TORQUE OFF function
- Internal EMC filter
- EMC compliance with shielding / grounding accessories
- Product rating, fusing and cabling information
- Brake resistor details (selection / ratings)

**Electric shock risk**

The voltages present in the following locations can cause severe electric shock and may be lethal:

- AC supply cables and connections
- DC and brake cables, and connections
- Output cables and connections
- Many internal parts of the drive, and external option units

Unless otherwise indicated, control terminals are single insulated and must not be touched.

**Isolation device**

The AC and / or DC power supply must be disconnected from the drive using an approved isolation device before any cover is removed from the drive or before any servicing work is performed.

**STOP function**

The STOP function does not remove dangerous voltages from the drive, the motor or any external option units.

**SAFE TORQUE OFF function**

The SAFE TORQUE OFF function does not remove dangerous voltages from the drive, the motor or any external option units.

**Stored charge**

The drive contains capacitors that remain charged to a potentially lethal voltage after the AC and / or DC power supply has been disconnected. If the drive has been energized, the AC and / or DC power supply must be isolated at least ten minutes before work may continue. Normally, the capacitors are discharged by an internal resistor. Under certain, unusual fault conditions, it is possible that the capacitors may fail to discharge, or be prevented from being discharged by a voltage applied to the output terminals. If the drive has failed in a manner that causes the display to go blank immediately, it is possible the capacitors will not be discharged. In this case, consult Control Techniques or their authorized distributor.

**Equipment supplied by plug and socket**

Special attention must be given if the drive is installed in equipment which is connected to the AC supply by a plug and socket. The AC supply terminals of the drive are connected to the internal capacitors through rectifier diodes which are not intended to give safety isolation. If the plug terminals can be touched when the plug is disconnected from the socket, a means of automatically isolating the plug from the drive must be used (e.g. a latching relay).



**WARNING**

### Permanent magnet motors

Permanent magnet motors generate electrical power if they are rotated, even when the supply to the drive is disconnected. If that happens then the drive will become energized through its motor terminals.

If the motor load is capable of rotating the motor when the supply is disconnected, then the motor must be isolated from the drive before gaining access to any live parts.

If the heatsink mounted resistor is used, an overload protection device is not required. The resistor is designed to fail safely under fault conditions.

For further information on ground connections, refer to the *Drive Installation Guide*.

## 3.1 Communications connections

The *Unidrive HS70 / HS72* drive offers Ethernet fieldbus communications and the *Unidrive HS71* drive offers a 2 wire 485 interface. This enables the drive set-up, operation and monitoring to be carried out with a PC or controller if required.

**Figure 3-1 Location of the comms connectors**

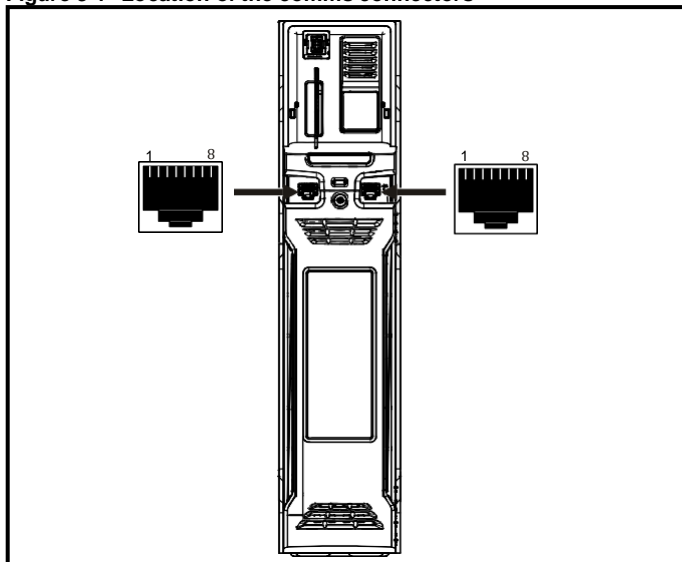

### 3.1.1 Unidrive HS70 / HS72 Ethernet fieldbus communications

The Ethernet option provides two RJ45 connections with an Ethernet switch for easy network creation.

Standard UTP (unshielded twisted pair) or STP (shielded twisted pair) cables are supported. It is recommended that a minimum specification CAT5e is used in new installations. As the drive supports the 'Auto cross-over detection' a cross-over cable is not required.

**NOTE**

The shell of the RJ45 connector is isolated from the 0 V of the drive control terminals but it is connected to ground.

### 3.1.2 Unidrive HS71 485 serial communications

The 485 option provides two parallel RJ45 connectors allowing easy daisy chaining. The drive only supports Modbus RTU protocol. See Table 3-1 for the connection details.

**NOTE**

Standard Ethernet cables are not recommended for use when connecting drives on a 485 network as they do not have the correct twisted pairs for the pinout of the serial comms port.

**Table 3-1 Serial communication port pin-outs**

Pin	Function
1	120 $\Omega$ Termination resistor
2	RX TX
3	Isolated 0 V
4	+24 V (100 mA)
5	Isolated 0 V
6	TX enable
7	RX\ TX\
8	RX\ TX\ (if termination resistors are required, link to pin 1)
Shell	Isolated 0 V

Minimum number of connections are 2, 3, 7 and shield.

### 3.1.3 Unidrive HS71 Isolation of the 485 serial communications port

The serial PC communications port is double insulated and meets the requirements for SELV in EN 50178:1998.



**WARNING** In order to meet the requirements for SELV in IEC60950 (IT equipment) it is necessary for the control computer to be grounded. Alternatively, when a lap-top or similar device is used which has no provision for grounding, an isolation device must be incorporated in the communications lead.

An isolated serial communications lead has been designed to connect the drive to IT equipment (such as laptop computers), and is available from the supplier of the drive. See below for details:

**Table 3-2 Isolated serial comms lead details**

Part number	Description
4500-0096	CT USB Comms cable

The "isolated serial communications" lead has reinforced insulation as defined in IEC60950 for altitudes up to 3,000 m.

## 3.2 Control connections

### 3.2.1 24 Vdc supply

The 24 Vdc supply connected to control terminals 1 & 2 provides the following functions:

- It can be used to supplement the drive's own internal 24 V supply when multiple option modules are being used and the current drawn by these module is greater than the drive can supply.
- It can be used as a back-up power supply to keep the control circuits of the drive powered up when the line power supply is removed. This allows any fieldbus modules, application modules, encoders or serial communications to continue to operate.
- It can be used to commission the drive when the line power supply is not available, as the display operates correctly. However, the drive will be in the Under voltage trip state unless either line power supply or low voltage DC operation is enabled, therefore diagnostics may not be possible. (Power down save parameters are not saved when using the 24 V back-up power supply input).
- If the DC bus voltage is too low to run the main SMPS in the drive, then the 24 V supply can be used to supply all the low voltage power requirements of the drive. *Low Under Voltage Threshold Select* (06.067) must also be enabled for this to happen.

**NOTE**

On size 6 and larger, if the power 24 Vdc supply is not connected none of the above mentioned functions can be used and "Waiting For Power Systems" will be displayed on the keypad. The location of the power 24 Vdc terminals can be identified from the Drive Installation Guide.

**Table 3-3 24 Vdc Supply connections**

Function	Terminal number*
Supplement the drive's internal supply	1, 2
Back-up supply for the control circuit	1, 2

\*Please note that frame sizes 6 and higher also require the 24 V to be connected to the power stage via terminals 51 and 52. See the *Drive Installation Guide* for connection details.

Minimum and maximum voltage values include ripple and noise. Ripple and noise values must not exceed 5 %.

### 3.2.2 Unidrive HS70 / HS71 control connections

**Table 3-4 The control connections consist of:**

Function	Qty	Control parameters available	Terminal number
Differential analog input	1	Mode, offset, invert, scaling	5, 6
Single ended analog input	2	Mode, offset, invert, scaling, destination	7, 8
Analog output	2	Source, scaling	9, 10
Digital input	3	Destination, invert, logic select	27, 28, 29
Digital input / output	3	Input / output mode select, destination / source, invert, logic select	24, 25, 26
Relay	1	Source, invert	41, 42
Drive enable (SAFE TORQUE OFF)	1		31
+10 V User output	1		4
+24 V User output	1	Source, invert	22
0V common	6		1, 3, 11, 21, 23, 30
+24V External input	1	Destination, invert	2

**Key:**

Destination parameter:	Indicates the parameter which is being controlled by the terminal / function
Source parameter:	Indicates the parameter being output by the terminal
Mode parameter:	Analog - indicates the mode of operation of the terminal, i.e. voltage 0-10 V, current 4-20 mA etc. Digital - indicates the mode of operation of the terminal, i.e. positive / negative logic (the Drive Enable terminal is fixed in positive logic), open collector.

All analog terminal functions can be programmed in menu 7.

All digital terminal functions (including the relay) can be programmed in menu 8.



**WARNING** The control circuits are isolated from the power circuits in the drive by basic insulation (single insulation) only. The installer must ensure that the external control circuits are insulated from human contact by at least one layer of insulation (supplementary insulation) rated for use at the AC supply voltage.



**WARNING** If the control circuits are to be connected to other circuits classified as Safety Extra Low Voltage (SELV) (e.g. to a personal computer), an additional isolating barrier must be included in order to maintain the SELV classification.



**CAUTION** If any of the digital inputs (including the drive enable input) are connected in parallel with an inductive load (i.e. contactor or motor brake) then suitable suppression (i.e. diode or varistor) should be used on the coil of the load. If no suppression is used then over voltage spikes can cause damage to the digital inputs and outputs on the drive.



Ensure the logic sense is correct for the control circuit to be used. Incorrect logic sense could cause the motor to be started unexpectedly.  
Positive logic is the default state for the drive.

**NOTE**

Any signal cables which are carried inside the motor cable (i.e. motor thermistor, motor brake) will pick up large pulse currents via the cable capacitance. The shield of these signal cables must be connected to ground close to the point of exit of the motor cable, to avoid this noise current spreading through the control system.

**NOTE**

The SAFE TORQUE OFF drive enable terminal is a positive logic input only. It is not affected by the setting of *Input Logic Polarity* (08.029).

**NOTE**

The common 0 V from analog signals should, wherever possible, not be connected to the same 0 V terminal as the common 0 V from digital signals. Terminals 3 and 11 should be used for connecting the 0V common of analog signals and terminals 21, 23 and 30 for digital signals. This is to prevent small voltage drops in the terminal connections causing inaccuracies in the analog signals.

**Figure 3-2 Default terminal functions**

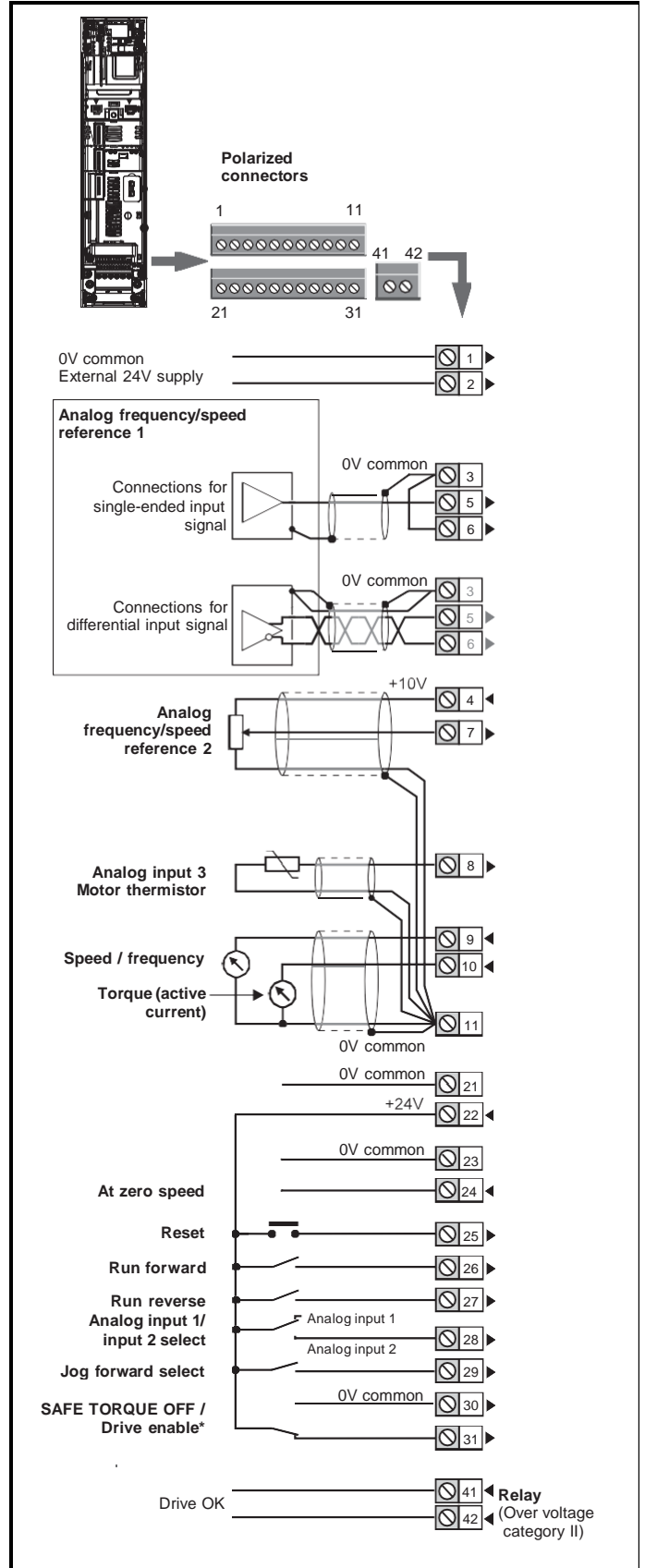

\*The SAFE TORQUE OFF / Drive enable terminal is a positive logic input only.

### 3.2.3 Unidrive HS70 / HS71 control terminal specification

<b>1</b>	<b>0V common</b>
<b>Function</b>	<b>Common connection for all external devices</b>

<b>2</b>	<b>+24V external input</b>
<b>Function</b>	<b>To supply the control circuit without providing a supply to the power stage</b>
Programmability	Can be used as digital input when using an external 24 V supply
Sample / update	2 ms
Nominal voltage	+24.0 Vdc
Minimum continuous operating voltage	+19.2 Vdc
Maximum continuous operating voltage	+28.0 Vdc
Minimum start-up voltage	21.6 Vdc
Recommended power supply	40 W 24 Vdc nominal
Recommended fuse	3 A, 50 Vdc

<b>3</b>	<b>0V common</b>
<b>Function</b>	<b>Common connection for all external devices</b>

<b>4</b>	<b>+10V user output</b>
<b>Function</b>	<b>Supply for external analog devices</b>
Voltage	10.2 V nominal
Voltage tolerance	±1 %
Nominal output current	10 mA
Protection	Current limit and trip @ 30 mA

<b>Precision reference Analog input 1</b>	
<b>5</b>	<b>Non-inverting input</b>
<b>6</b>	<b>Inverting input</b>
<b>Default function</b>	<b>Frequency/speed reference</b>
Type of input	Bipolar differential analog voltage or current, thermistor input
Mode controlled by:	Pr <b>07.007</b>
<b>Operating in Voltage mode</b>	
Full scale voltage range	±10 V ±2 %
Maximum offset	±10 mV
Absolute maximum voltage range	±36 V relative to 0 V
Working common mode voltage range	±13 V relative to 0 V
Input resistance	≥100 k $\Omega$
Monotonic	Yes (including 0 V)
Dead band	None (including 0 V)
Jumps	None (including 0 V)
Maximum offset	20 mV
Maximum non linearity	0.3% of input
Maximum gain asymmetry	0.5 %
Input filter bandwidth single pole	~3 kHz
<b>Operating in current mode</b>	
Current ranges	0 to 20 mA ±5 %, 20 to 0 mA ±5 %, 4 to 20 mA ±5 %, 20 to 4 mA ±5 %
Maximum offset	250 $\mu$ A
Absolute maximum voltage (reverse biased)	±36 V relative to 0 V
Equivalent input resistance	≤300 $\Omega$
Absolute maximum current	±30 mA
<b>Operating in thermistor input mode (in conjunction with analog input 3)</b>	
Internal pull-up voltage	2.5 V
Trip threshold resistance	User defined in Pr <b>07.048</b>
Short-circuit detection resistance	50 $\Omega$ ± 40 %
<b>Common to all modes</b>	
Resolution	12 bits (11 bits plus sign)
Sample / update period	250 $\mu$ s with destinations Pr <b>01.036</b> , Pr <b>01.037</b> , Pr <b>03.022</b> or Pr <b>04.008</b> in RFC-A and RFC-S modes. 4 ms for open loop mode and all other destinations in RFC-A or RFC-S modes.

7 Analog input 2	
<b>Default function</b>	<b>Frequency / speed reference</b>
Type of input	Bipolar single-ended analog voltage or unipolar current
Mode controlled by...	Pr <b>07.011</b>
<b>Operating in voltage mode</b>	
Full scale voltage range	$\pm 10 \text{ V} \pm 2 \%$
Maximum offset	$\pm 10 \text{ mV}$
Absolute maximum voltage range	$\pm 36 \text{ V}$ relative to 0 V
Input resistance	$\geq 100 \text{ k} \Omega$
<b>Operating in current mode</b>	
Current ranges	0 to 20 mA $\pm 5 \%$ , 20 to 0 mA $\pm 5 \%$ , 4 to 20 mA $\pm 5 \%$ , 20 to 4 mA $\pm 5 \%$
Maximum offset	250 $\mu\text{A}$
Absolute maximum voltage (reverse bias)	$\pm 36 \text{ V}$ relative to 0V
Absolute maximum current	$\pm 30 \text{ mA}$
Equivalent input resistance	$\leq 300 \Omega$
<b>Common to all modes</b>	
Resolution	12 bits (11 bits plus sign)
Sample / update	250 $\mu\text{s}$ with destinations Pr <b>01.036</b> , Pr <b>01.037</b> or Pr <b>03.022</b> , Pr <b>04.008</b> in RFC-A or RFC-S. 4ms for open loop mode and all other destinations in RFC-A or RFC-S mode.

8 Analog input 3	
<b>Default function</b>	<b>Thermistor input</b>
Type of input	Bipolar single-ended analog voltage, or thermistor input
Mode controlled by...	Pr <b>07.015</b>
<b>Operating in Voltage mode (default)</b>	
Voltage range	$\pm 10 \text{ V} \pm 2 \%$
Maximum offset	$\pm 10 \text{ mV}$
Absolute maximum voltage range	$\pm 36 \text{ V}$ relative to 0 V
Input resistance	$\geq 100 \text{ k} \Omega$
<b>Operating in thermistor input mode</b>	
Supported thermistor types	Din 4408, KTY 84, PT100, PT 1000, PT 2000
Internal pull-up voltage	2.5 V
Trip threshold resistance	User defined in Pr <b>07.048</b>
Reset resistance	User defined in Pr <b>07.048</b>
Short-circuit detection resistance	50 $\Omega \pm 40 \%$
<b>Common to all modes</b>	
Resolution	12 bits (11 bits plus sign)
Sample / update period	4 ms

9 Analog output 1	
10 Analog output 2	
<b>Terminal 9 default function</b>	<b>OL&gt; Motor FREQUENCY output signal</b> <b>RFC&gt; SPEED output signal</b>
<b>Terminal 10 default function</b>	<b>Motor active current</b>
Type of output	Bipolar single-ended analog voltage
<b>Operating in Voltage mode (default)</b>	
Voltage range	$\pm 10 \text{ V} \pm 5 \%$
Maximum offset	$\pm 120 \text{ mV}$
Maximum output current	$\pm 20 \text{ mA}$
Load resistance	$\geq 1 \text{ k} \Omega$
Protection	20 mA max. Short circuit protection
<b>Common to all modes</b>	
Resolution	10-bit
Sample / update period	250 $\mu\text{s}$ (output will only change at update the rate of the source parameter if slower)

11 0V common	
<b>Function</b>	<b>Common connection for all external devices</b>

21 0V common	
<b>Function</b>	<b>Common connection for all external devices</b>

22 +24 V user output (selectable)	
<b>Terminal 22 default function</b>	<b>+24 V user output</b>
Programmability	Can be switched on or off to act as a fourth digital output (positive logic only) by setting the source Pr <b>08.028</b> and source invert Pr <b>08.018</b>
Nominal output current	100 mA combined with DIO3
Maximum output current	100 mA 200 mA (total including all Digital I/O)
Protection	Current limit and trip
Sample / update period	2 ms when configured as an output (output will only change at the update rate of the source parameter if slower)

23 0V common	
<b>Function</b>	<b>Common connection for all external devices</b>

Refer to section 3.4 **SAFE TORQUE OFF (STO)** on page 29 for further information.

<b>24</b>	<b>Digital I/O 1</b>
<b>25</b>	<b>Digital I/O 2</b>
<b>26</b>	<b>Digital I/O 3</b>
<b>Terminal 24 default function</b>	<b>AT ZERO SPEED output</b>
<b>Terminal 25 default function</b>	<b>DRIVE RESET input</b>
<b>Terminal 26 default function</b>	<b>RUN FORWARD input</b>
Type	Positive or negative logic digital inputs, positive logic voltage source outputs
Input / output mode controlled by...	Pr <b>08.031</b> , Pr <b>08.032</b> and Pr <b>08.033</b>
<b>Operating as an input</b>	
Logic mode controlled by...	Pr <b>08.029</b>
Absolute maximum applied voltage range	-3 V to +30 V
Impedance	>2 mA @15 V from IEC 61131-2, type 1, 6.6 k $\Lambda$
Input thresholds	10 V $\pm$ 0.8 V from IEC 61131-2, type 1
<b>Operating as an output</b>	
Nominal maximum output current	100 mA (DIO1 & 2 combined) 100 mA (DIO3 & 24 V User Output Combined)
Maximum output current	100 mA 200 mA (total including all Digital I/O)
<b>Common to all modes</b>	
Voltage range	0 V to +24 V
Sample / Update period	2 ms (output will only change at the update rate of the source parameter)

<b>31</b>	<b>SAFE TORQUE OFF function (drive enable)</b>
Type	Positive logic only digital input
Voltage range	0 V to +24 V
Absolute maximum applied voltage	30 V
Logic Threshold	10 V $\pm$ 5 V
Low state maximum voltage for disable to SIL3 and PL e	5 V
Impedance	>4 mA @15 V from IEC 61131-2, type 1, 3.3 k $\Lambda$
Low state maximum current for disable to SIL3 and PL e	0.5 mA
Response time	Nominal: 8 ms Maximum: 20 ms
The SAFE TORQUE OFF function may be used in a safety-related application in preventing the drive from generating torque in the motor to a high level of integrity. The system designer is responsible for ensuring that the complete system is safe and designed correctly according to the relevant safety standards. If the SAFE TORQUE OFF function is not required, this terminal is used for enabling the drive.	

<b>27</b>	<b>Digital Input 4</b>
<b>28</b>	<b>Digital Input 5</b>
<b>Terminal 27 default function</b>	<b>RUN REVERSE input</b>
<b>Terminal 28 default function</b>	<b>Analog INPUT 1 / INPUT 2 select</b>
Type	Negative or positive logic digital inputs
Logic mode controlled by...	Pr <b>08.029</b>
Voltage range	0 V to +24 V
Absolute maximum applied voltage range	-3 V to +30 V
Impedance	>2 mA @15 V from IEC 61131-2, type 1, 6.6 k $\Lambda$
Input thresholds	10 V $\pm$ 0.8 V from IEC 61131-2, type 1
Sample / Update period	250 $\mu$ s when configured as an input with destinations Pr <b>06.035</b> or Pr <b>06.036</b> . 600 $\mu$ s when configured as an input with destination Pr <b>06.029</b> . 2 ms in all other cases.

<b>41</b>	<b>Relay contacts</b>
<b>42</b>	<b>Relay contacts</b>
<b>Default function</b>	<b>Drive OK indicator</b>
Contact voltage rating	240 Vac, Installation over-voltage category II
Contact maximum current rating	2 A AC 240 V 4 A DC 30 V resistive load 0.5 A DC 30 V inductive load (L/R = 40 ms)
Contact minimum recommended rating	12 V 100 mA
Contact type	Normally open
Default contact condition	Closed when power applied and drive OK
Update period	4 ms

<b>29</b>	<b>Digital Input 6</b>
<b>Terminal 29 default function</b>	<b>JOG SELECT input</b>
Type	Negative or positive logic digital inputs
Logic mode controlled by...	Pr <b>08.029</b>
Voltage range	0 V to +24 V
Absolute maximum applied voltage range	-3 V to +30 V
Impedance	>2 mA @15 V from IEC 61131-2, type 1, 6.6 k $\Lambda$
Input thresholds	10 V $\pm$ 0.8 V from IEC 61131-2, type 1
Sample / Update period	2 ms

<b>51</b>	<b>0 V</b>
<b>52</b>	<b>+24 Vdc</b>
<b>Size 6</b>	
Nominal operating voltage	24.0 Vdc
Minimum continuous operating voltage	18.6 Vdc
Maximum continuous operating voltage	28.0 Vdc
Minimum startup voltage	18.4 Vdc
Maximum power supply requirement	40 W
Recommended fuse	4 A @ 50 Vdc
<b>Size 7 to 10</b>	
Nominal operating voltage	24.0 Vdc
Minimum continuous operating voltage	19.2 Vdc
Maximum continuous operating voltage	30 Vdc (IEC), 26 Vdc (UL)
Minimum startup voltage	21.6 Vdc
Maximum power supply requirement	60 W
Recommended fuse	4 A @ 50 Vdc

<b>30</b>	<b>0V common</b>
<b>Function</b>	<b>Common connection for all external devices</b>

	To prevent the risk of a fire hazard in the event of a fault, a fuse or other over-current protection must be installed in the relay circuit.
<b>WARNING</b>	

3.2.4 Unidrive HS72 control connections

Table 3-5 The control connections consist of:

Function	Qty	Control parameters available	Terminal number
Digital input	2	Destination, invert, logic select	7, 8
Digital input / output	2	Input / output mode select, destination / source, invert, logic select	4, 5
Relay	1	Source, invert	41, 42
Drive enable (SAFE TORQUE OFF)	2		11, 13
+24 V User output	1	Source, invert	2
0 V common	5		1, 3, 6, 10, 12
+24 V External input	1	Destination, invert	9

Key:

Destination parameter:	Indicates the parameter which is being controlled by the terminal / function
Source parameter:	Indicates the parameter being output by the terminal
Mode parameter:	Digital - indicates the mode of operation of the terminal, i.e. positive / negative logic (the Drive Enable terminal is fixed in positive logic), open collector.

All digital terminal functions (including the relay) can be programmed in menu 8.



**WARNING**

The control circuits are isolated from the power circuits in the drive by basic insulation (single insulation) only. The installer must ensure that the external control circuits are insulated from human contact by at least one layer of insulation (supplementary insulation) rated for use at the AC supply voltage.



**WARNING**

If the control circuits are to be connected to other circuits classified as Safety Extra Low Voltage (SELV) (e.g. to a personal computer), an additional isolating barrier must be included in order to maintain the SELV classification.



**CAUTION**

If any of the digital inputs (including the drive enable input) are connected in parallel with an inductive load (i.e. contactor or motor brake) then suitable suppression (i.e. diode or varistor) should be used on the coil of the load. If no suppression is used then over voltage spikes can cause damage to the digital inputs and outputs on the drive.



**CAUTION**

Ensure the logic sense is correct for the control circuit to be used. Incorrect logic sense could cause the motor to be started unexpectedly. Positive logic is the default state for the drive.

**NOTE**

Any signal cables which are carried inside the motor cable (i.e. motor thermistor, motor brake) will pick up large pulse currents via the cable capacitance. The shield of these signal cables must be connected to ground close to the point of exit of the motor cable, to avoid this noise current spreading through the control system.

**NOTE**

The SAFE TORQUE OFF drive enable terminal is a positive logic input only. It is not affected by the setting of *Input Logic Polarity* (08.029).

Figure 3-3 Default terminal functions

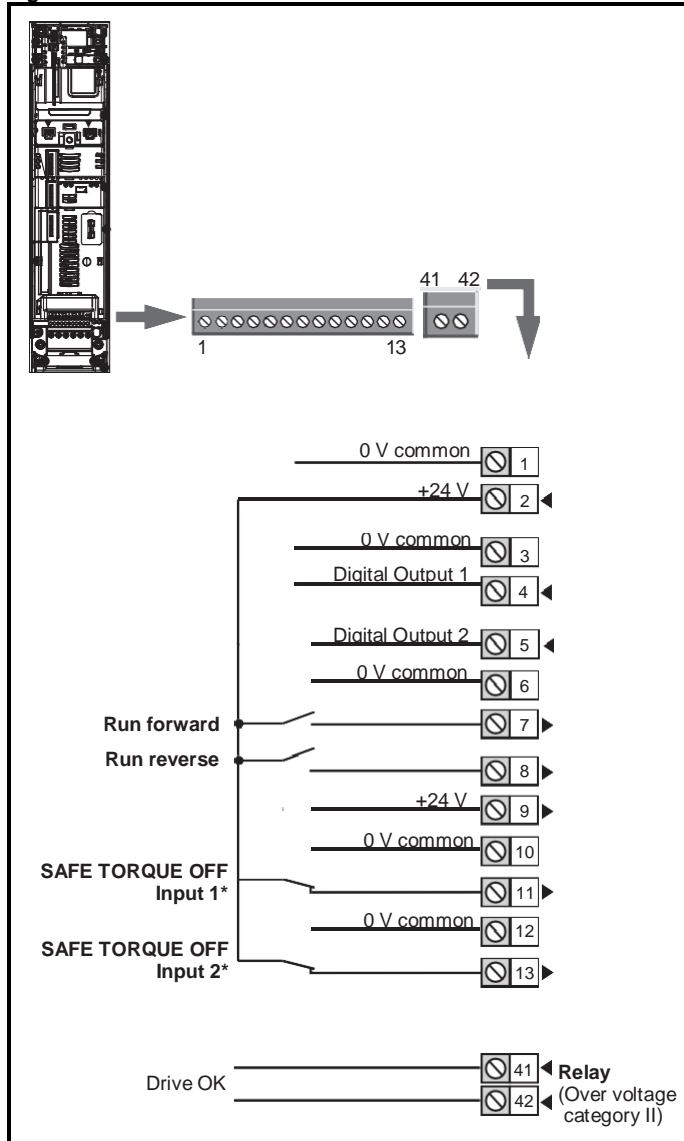

\*The SAFE TORQUE OFF / Drive enable terminal is a positive logic input only.

### 3.2.5 Unidrive HS72 control terminal specification

<b>1</b>	<b>0 V common</b>
<b>Function</b>	<b>Common connection for all external devices</b>

<b>2</b>	<b>+24 V user output (selectable)</b>
<b>Terminal 2 default function</b>	<b>+24 V user output</b>
Programmability	Can be switched on or off to act as a fourth digital output (positive logic only) by setting the source Pr <b>08.028</b> and source invert Pr <b>08.018</b>
Nominal output current	100 mA
Maximum output current	100 mA 200 mA (total including all Digital I/O)
Protection	Current limit and trip
Sample / update period	2 ms when configured as an output (output will only change at the update rate of the source parameter if slower)

<b>3</b>	<b>0 V common</b>
<b>Function</b>	<b>Common connection for all external devices</b>

<b>4</b>	<b>Digital Output 1</b>
<b>5</b>	<b>Digital Output 2</b>
<b>Terminal 4 default function</b>	<b>AT ZERO SPEED output</b>
<b>Terminal 5 default function</b>	
Type	Positive logic voltage source outputs
Input / output mode controlled by...	Pr <b>08.031</b> , Pr <b>08.032</b>
<b>Operating as an input</b>	
Logic mode controlled by...	Pr <b>08.029</b>
Absolute maximum applied voltage range	-3 V to +30 V
Impedance	>2 mA @15 V from IEC 61131-2, type 1, 6.6 k $\Omega$
Input thresholds	10 V $\pm$ 0.8 V from IEC 61131-2, type 1
<b>Operating as an output</b>	
Nominal maximum output current	100 mA (DIO1 & 2 combined)
Maximum output current	100 mA 200 mA (total including all Digital I/O)
<b>Common to all modes</b>	
Voltage range	0 V to +24 V
Sample / Update period	2 ms (output will only change at the update rate of the source parameter)

<b>6</b>	<b>0 V common</b>
<b>Function</b>	<b>Common connection for all external devices</b>

<b>7</b>	<b>Digital Input 4</b>
<b>8</b>	<b>Digital Input 5</b>
<b>Terminal 7 default function</b>	<b>RUN FORWARD input</b>
<b>Terminal 8 default function</b>	<b>RUN REVERSE input</b>
Type	Negative or positive logic digital inputs
Logic mode controlled by...	Pr <b>08.029</b>
Voltage range	0 V to +24 V
Absolute maximum applied voltage range	-3 V to +30 V
Impedance	>2 mA @15 V from IEC 61131-2, type 1, 6.6 k $\Omega$
Input thresholds	10 V $\pm$ 0.8 V from IEC 61131-2, type 1
Sample / Update period	250 $\mu$ s when configured as an input with destinations Pr <b>06.035</b> or Pr <b>06.036</b> . 600 $\mu$ s when configured as an input with destination Pr <b>06.029</b> . 2 ms in all other cases.

<b>9</b>	<b>+24 V external input</b>
<b>Function</b>	<b>To supply the control circuit without providing a supply to the power stage</b>
Programmability	Can be used as a digital input when using an external 24 Vdc
Sample / Update period	2 ms
Nominal voltage	+24.0 Vdc
Minimum continuous operating voltage	+19.2 Vdc
Maximum continuous operating voltage	+28.0 Vdc
Minimum start-up voltage	21.6 Vdc
Recommended power supply	40 W 24 Vdc nominal
Recommended fuse	3 A, 50 Vdc

<b>10</b>	<b>0 V common</b>
<b>Function</b>	<b>Common connection for all external devices</b>

<b>12</b>	<b>0 V common</b>
<b>Function</b>	<b>Common connection for all external devices</b>

<b>11</b>	<b>SAFE TORQUE OFF function input 1 (drive enable)</b>
<b>13</b>	<b>SAFE TORQUE OFF function input 2 (drive enable)</b>
Type	Positive logic only digital input
Voltage range	0 V to +24 V
Absolute maximum applied voltage	30 V
Logic Threshold	10 V ± 5 V
Low state maximum voltage for disable to SIL3 and PL e	5 V
Impedance	>4 mA @15 V from IEC 61131-2, type 1, 3.3 k Ω
Low state maximum current for disable to SIL3 and PL e	0.5 mA
Response time	Nominal: 8 ms Maximum: 20 ms
The SAFE TORQUE OFF function may be used in a safety-related application in preventing the drive from generating torque in the motor to a high level of integrity. The system designer is responsible for ensuring that the complete system is safe and designed correctly according to the relevant safety standards. If the SAFE TORQUE OFF function is not required, these terminals are used for enabling the drive.	

Refer to section 3.4 *SAFE TORQUE OFF (STO)* on page 29 for further information.

<b>41</b>	<b>Relay contacts</b>
<b>42</b>	<b>Relay contacts</b>
<b>Default function</b>	<b>Drive OK indicator</b>
Contact voltage rating	240 Vac, Installation over-voltage category II
Contact maximum current rating	2 A AC 240 V 4 A DC 30 V resistive load 0.5 A DC 30 V inductive load (L/R = 40 ms)
Contact minimum recommended rating	12 V 100 mA
Contact type	Normally open
Default contact condition	Closed when power applied and drive OK
Update period	4 ms

<b>51</b>	<b>0 V</b>
<b>52</b>	<b>+24 Vdc</b>
<b>Size 6</b>	
Nominal operating voltage	24.0 Vdc
Minimum continuous operating voltage	18.6 Vdc
Maximum continuous operating voltage	28.0 Vdc
Minimum startup voltage	18.4 Vdc
Maximum power supply requirement	40 W
Recommended fuse	4 A @ 50 Vdc
<b>Size 7 to 10</b>	
Nominal operating voltage	24.0 Vdc
Minimum continuous operating voltage	19.2 Vdc
Maximum continuous operating voltage	30 Vdc (IEC), 26 Vdc (UL)
Minimum startup voltage	21.6 Vdc
Maximum power supply requirement	60 W
Recommended fuse	4 A @ 50 Vdc



To prevent the risk of a fire hazard in the event of a fault, a fuse or other over-current protection must be installed in the relay circuit.

**WARNING**

### 3.3 Position feedback connections

The following functions are provided via the 15-way high density D-type connector on the drive:

- Two position feedback interfaces (P1 and P2).
- One encoder simulation output.
- Two freeze trigger inputs (marker inputs).
- One thermistor input.

The P1 position interface is always available but the availability of the P2 position interface and the encoder simulation output depends on the position feedback device used on the P1 position interface, as shown in Table 3-8.

#### 3.3.1 Location of position feedback connector

Figure 3-4 Location of the position feedback

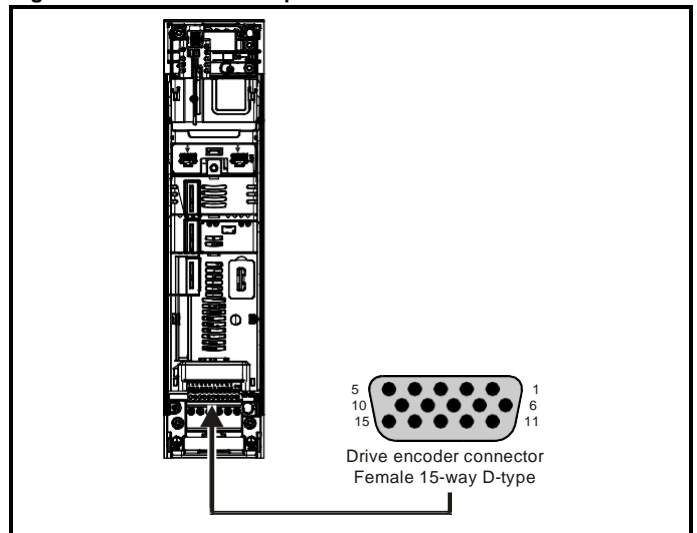

### 3.3.2 Compatible position feedback devices

**Table 3-6 Supported feedback devices on the P1 position interface**

Encoder type	Pr 3.038 setting
Quadrature incremental encoders with or without marker pulse	AB (0)
Quadrature incremental encoders with UVW commutation signals for absolute position for permanent magnet motors with or without marker pulse	AB Servo (3)
Forward / reverse incremental encoders with or without marker pulse	FR (2)
Forward / reverse incremental encoders with UVW commutation signals for absolute position for permanent magnet motors with or without marker pulse	FR Servo (5)
Frequency and direction incremental encoders with or without marker pulse	FD (1)
Frequency and direction incremental encoders with UVW commutation signals for absolute position for permanent magnet motors with or without marker pulse	FD Servo (4)
Sincos incremental encoders	SC (6)
Sincos incremental with commutation signals	SC Servo (12)
Heidenhain sincos encoders with EnDat comms for absolute position	SC EnDat (9)
Stegmann sincos encoders with Hiperface comms for absolute position	SC Hiperface (7)
Sincos encoders with SSI comms for absolute position	SC SSI (11)
Sincos incremental with absolute position from single sin and cosine signals	SC SC (15)
SSI encoders (Gray code or binary)	SSI (10)
EnDat communication only encoders	EnDat (8)
BiSS communication only encoders (not currently supported)	BiSS (13)
Resolver	Resolver (14)
UVW commutation only encoders* (not currently supported)	Commutation only (16)

\* This feedback device provides very low resolution feedback and should not be used for applications requiring a high level of performance

**Table 3-7 Supported feedback devices on the P2 position interface**

Encoder type	Pr 3.138 setting
Quadrature incremental encoders with or without marker pulse	AB (1)
Frequency and direction incremental encoders with or without marker pulse	FD (2)
Forward / reverse incremental encoders with or without marker pulse	FR (3)
EnDat communication only encoders	EnDat (4)
SSI encoders (Gray code or binary)	SSI (5)
BiSS communication only encoders (not currently supported)	BiSS (6)

Table 3-8 shows the possible combinations of position feedback device types connected to the P1 and P2 position interfaces and the availability of the encoder simulation output.

**Table 3-8 Availability of the P2 position feedback interface and the encoder simulation output**

Functions		
P1 Position feedback interface	P2 Position feedback interface	Encoder Simulation Output
AB Servo FD Servo FR Servo SC Servo SC SC Commutation only	None	None
AB FD FR SC Resolver SC Hiperface	AB, FD, FR EnDat, BiSS, SSI	None
	None	Full
SC EnDat SC SSI	AB, FD, FR (No Z marker pulse input)	None
	EnDat, BiSS, SSI (with freeze input)	
	None	No Z marker pulse output
EnDat BiSS SSI	AB, FD, FR EnDat, BiSS, SSI	None
	None	Full
	EnDat, BiSS, SSI	No Z marker pulse output

The priority of the position feedback interfaces and the encoder simulation output on the 15-way D-type is assigned in the following order from the highest priority to the lowest.

- P1 position interface (highest)
- Encoder simulation output
- P2 position interface (lowest)

For example, if an AB Servo type position feedback device is selected for use on the P1 position interface, then both the encoder simulation output and the P2 position interface will not be available as this device uses all connections of the 15-way D-type connector. Also, if an AB type position feedback device is selected for use on the P1 position interface and Pr **03.085** is set to a valid source for the encoder simulation output, then the P2 position interface will not be available.

Depending on the device type used on the P1 position interface, the encoder simulation output may not be able support a marker pulse output (e.g. SC EnDat or SC SSI device types). Pr **03.086** shows the status of the encoder simulation output indicating whether the output is disabled, no marker pulse is available or full encoder simulation is available.

**NOTE**

When using the P1 and P2 position interfaces and the encoder simulation output together, the P2 position interface uses alternative connections on the 15-way D-type connector. Pr **03.172** shows the status of the P2 position interface and indicates if alternative connections are being used for the P2 position interface.

### 3.3.3 Position feedback connection details

Table 3-9 P1 Position feedback connection details

P1 Position feedback interface Pr 03.038	Connections														
	1	2	3	4	5	6	7	8	9	10	11	12	13	14	15
AB (0)	A	A\	B	B\	Z	Z\									
FD (1)	F	F\	D	D\	Z	Z\									
FR (2)	F	F\	R	R\	Z	Z\									
AB Servo (3)	A	A\	B	B\	Z	Z\	U	U\	V	V\	W	W\			
FD Servo (4)	F	F\	D	D\	Z	Z\	U	U\	V	V\	W	W\			
FR Servo (5)	F	F\	R	R\	Z	Z\	U	U\	V	V\	W	W\			
SC (6)	A (Cos)	A\ (Cos\)	B (Sin)	B\ (Sin\)	Z	Z\									
SC Hiperface (7)	Cos	Cosref	Sin	Sinref	DATA	DATA\									
EnDat (8)	DATA	DATA\	CLK	CLK\	Freeze	Freeze\							+V	0V	Th
SC EnDat (9)	A	A\	B	B\	DATA	DATA\					CLK	CLK\			
SSI (10)	DATA	DATA\	CLK	CLK\	Freeze	Freeze\									
SC SSI (11)	A (Cos)	A\ (Cos\)	B (Sin)	B\ (Sin\)	DATA	DATA\					CLK	CLK\			
SC Servo (12)	A (Cos)	A\ (Cos\)	B (Sin)	B\ (Sin\)	Z	Z\	U	U\	V	V\	W	W\			
BiSS (13)	DATA	DATA\	CLK	CLK\	Freeze	Freeze\									
Resolver (14)	Cos H	Cos L	Sin H	Sin L	Ref H	Ref L									
SC SC (15)	A (Cos)	A\ (Cos\)	B (Sin)	B\ (Sin\)	Z	Z\	C*1	C\*1	D*2	D\*2	Freeze2	Freeze2\			
Commutation Only (16)							U	U\	V	V\	W	W\			

\*1 - One sine wave per revolution

\*2 - One cosine wave per revolution

Greyed cells are for P2 position feedback connections or simulated encoder outputs.

**NOTE**

Freeze and Freeze\ on terminals 5 and 6 are for Freeze input 1. Freeze2 and Freeze2\ on terminals 11 and 12 are for Freeze input 2.

**Table 3-10 P2 Position feedback and encoder simulation output connection details**

P1 Position feedback interface Pr 03.038	P2 Position feedback interface Pr 03.138	Encoder Simulation Output	Connections							
			5	6	7	8	9	10	11	12
AB (0) FD (1) FR (2) SC (6) SC Hiperface (7) Resolver (14)	AB (1)	Disabled* <sup>1</sup>			A	A\	B	B\	Z	Z\
	FD (2)				F	F\	D	D\	Z	Z\
	FR (3)				F	F\	R	R\	Z	Z\
	EnDat (4) SSI (5) BiSS (6)				DATA	DATA\	CLK	CLK\	Freeze2	Freeze2\
	None (0)	AB			Asim	Asim\	Bsim	Bsim\	Zsim	Zsim\
		FD			Fsim	Fsim\	Dsim	Dsim\	Zsim	Zsim\
		FR			Fsim	Fsim\	Rsim	Rsim\	Zsim	Zsim\
		SSI			DATAsim	DATAsim\	CLKsim	CLKsim\		
SC EnDat (9) SC SSI (11)	AB (1)	Disabled* <sup>1</sup>			A	A\	B	B\		
	FD (2)				F	F\	D	D\		
	FR (3)				F	F\	R	R\		
	EnDat (4) SSI (5) BiSS (6)				DATA	DATA\	CLK	CLK\		
	None (0)	AB			Asim	Asim\	Bsim	Bsim\		
		FD			Fsim	Fsim\	Dsim	Dsim\		
		FR			Fsim	Fsim\	Rsim	Rsim\		
		SSI			DATAsim	DATAsim\	CLKsim	CLKsim\		
EnDat (8) SSI (10) BiSS (13)	AB (1)	Disabled* <sup>1</sup>			A	A\	B	B\	Z	Z\
	FD (2)				F	F\	D	D\	Z	Z\
	FR (3)				F	F\	R	R\	Z	Z\
	EnDat (4) SSI (5) BiSS (6)				DATA	DATA\	CLK	CLK\	Freeze2	Freeze2\
	None (0)	AB			Asim	Asim\	Bsim	Bsim\	Zsim	Zsim\
		FD			Fsim	Fsim\	Dsim	Dsim\	Zsim	Zsim\
		FR			Fsim	Fsim\	Rsim	Rsim\	Zsim	Zsim\
		SSI			DATAsim	DATAsim\	CLKsim	CLKsim\		
EnDat (8) SSI (10) BiSS (13) (with no Freeze inputs)	EnDat (4) SSI (5) BiSS (6)	AB	DATA	DATA\	Asim	Asim\	Bsim	Bsim\	CLK	CLK\
		FD	DATA	DATA\	Fsim	Fsim\	Dsim	Dsim\	CLK	CLK\
		FR	DATA	DATA\	Fsim	Fsim\	Rsim	Rsim\	CLK	CLK\
		SSI	DATA	DATA\	DATAsim	DATAsim\	CLKsim	CLKsim\	CLK	CLK\

\*<sup>1</sup> The encoder simulation output is disabled when Pr **03.085** is set to zero.

**NOTE**

The termination resistors are always enabled on the P2 position interface. Wire break detection is not available when using AB, FD or FR position feedback device types on the P2 position interface.

### 3.3.4 Position feedback terminal specifications

<b>1</b>	<b>A, F, Cosref, Data, Cos H</b>
<b>2</b>	<b>A, F Cosref, Data, Cos L</b>
<b>AB (0), FD (1), FR (2), AB Servo (3), FD Servo(4), FR Servo (5)</b>	
Type	EIA 485 differential receivers
Maximum input frequency	500 kHz
Line loading	
Line termination components	120 $\Omega$ (switchable)
Working common mode range	-7 V to +12 V
<b>SC Hiperface (7), SC EnDat (9), SC SSI (11), SC Servo (12), SC SC (15)</b>	
Type	Differential voltage
Maximum Signal level	1.25 V peak to peak (sin with regard to sinref and cos with regard to cosref)
Maximum input frequency	See Table 3-11
Maximum applied differential voltage and common mode voltage range	$\pm 4$ V
<b>Resolution:</b> The sine wave frequency can be up to 500 kHz but the resolution is reduced at high frequency. Table 3-11 shows the number of bits of interpolated information at different frequencies and with different voltage levels at the drive encoder port	
<b>EnDat (8), SSI (10), BISS (13)</b>	
Type	EIA 485 differential receivers
Maximum input frequency	4 MHz
Line loading	
Line termination components	120 $\Omega$ (switchable)
Working common mode range	-7 V to +12 V
<b>Resolver (14)</b>	
Type	2 Vrms sinusoidal signal
Operating Frequency	6 - 8 kHz
Input voltage	0.6 Vrms
<b>Common to All</b>	
Absolute maximum applied voltage relative to 0V	-9 V to 14 V

<b>3</b>	<b>B, D, R Sinref, Clock, Sin H</b>
<b>4</b>	<b>B, D, R, Sinref, Clock, Sin L</b>
<b>AB (0), FD (1), FR (2), AB Servo (3), FD Servo(4), FR Servo (5)</b>	
Type	EIA 485 differential receivers
Maximum input frequency	500 kHz
Line loading	
Line termination components	120 $\Omega$ (switchable)
Working common mode range	-7 V to +12 V
<b>SC Hiperface (7), SC EnDat (9), SC SSI (11), SC Servo (12), SC SC (15)</b>	
Type	Differential voltage
Maximum Signal level	1.25 V peak to peak (sin with regard to sinref and cos with regard to cosref)
Maximum input frequency	See Table 3-11
Maximum applied differential voltage and common mode voltage range	$\pm 4$ V
<b>Resolution:</b> The sine wave frequency can be up to 500 kHz but the resolution is reduced at high frequency. Table 3-11 shows the number of bits of interpolated information at different frequencies and with different voltage levels at the drive encoder port	
<b>EnDat (8), SSI (10), BISS (13)</b>	
Type	EIA 485 differential receivers
Maximum input frequency	4 MHz
Line loading	
Line termination components	120 $\Omega$ (switchable)
Working common mode range	-7 V to +12 V
<b>Resolver (14)</b>	
Type	2 Vrms sinusoidal signal
Operating Frequency	6 - 8 kHz
Input voltage	0.6 Vrms
<b>Common to All</b>	
Absolute maximum applied voltage relative to 0V	-9 V to 14 V

<b>5</b>	<b>Z, Data, Freeze, Ref H</b>
<b>6</b>	<b>Z\, Data\, Freeze\, Ref L</b>
<b>AB (0), FD (1), FR (2), AB Servo (3), FD Servo(4), FR Servo (5), SC SC (15)</b>	
Type	EIA 485 differential receivers
Maximum input frequency	512 kHz
Line loading	
Line termination components	120 $\Lambda$ (switchable)
Working common mode range	-7 V to +12 V
<b>SC Hiperface (7), SC EnDat (9), SC SSI (11), SC Servo (12)</b>	
Type	EIA 485 differential receivers
Maximum input frequency	4 MHz
Line loading	
Line termination components	120 $\Lambda$ (switchable)
Working common mode range	-7 V to +12 V
<b>EnDat (8), SSI (10), BiSS (13)</b>	
Type	EIA 485 differential receivers
Maximum input frequency	4 MHz
Line loading	
Line termination components	120 $\Lambda$ (switchable)
Working common mode range	-7 V to +12 V
<b>Resolver (14)</b>	
Type	Differential voltage
Nominal voltage	0 – 2 Vrms depending on turns ratio
Operating frequency	6 - 8 KHz
Line loading	
<b>Common to All</b>	
Absolute maximum applied voltage relative to 0V	-9 V to 14 V

<b>7</b>	<b>U, C, Not used, Not used</b>
<b>8</b>	<b>U\, C\, Not used, Not used</b>
<b>AB Servo (3), FD Servo(4), FR Servo (5), SC Servo (12)</b>	
Type	EIA 485 differential receivers
Maximum input frequency	512 kHz
Line loading	
Line termination components	120 $\Lambda$ (switchable)
Working common mode range	-7 V to +12 V
<b>SC SC (15)</b>	
Type	Differential voltage
Maximum Signal level	1.25 V peak to peak (sin with regard to sinref and cos with regard to cosref)
Maximum input frequency	See Table 3-11
Maximum applied differential voltage and common mode voltage range	$\pm 4$ V
<b>EnDat (8), SSI (10), BiSS (13)</b>	
Not used	
<b>Resolver (14)</b>	
Not used	
<b>Common to All</b>	
Absolute maximum applied voltage relative to 0V	-9 V to 14 V

<b>9</b>	<b>V, D, Not used, Not used</b>
<b>10</b>	<b>V\, D\, Not used, Not used</b>
<b>AB Servo (3), FD Servo(4), FR Servo (5), SC Servo (12)</b>	
Type	EIA 485 differential receivers
Maximum input frequency	512 kHz
Line loading	
Line termination components	120 $\Lambda$ (switchable)
Working common mode range	-7 V to +12 V
<b>SC SC (15)</b>	
Type	Differential voltage
Maximum Signal level	1.25 V peak to peak (sin with regard to sinref and cos with regard to cosref)
Maximum input frequency	See Table 3-11
Maximum applied differential voltage and common mode voltage range	$\pm 4$ V
<b>EnDat (8), SSI (10), BiSS (13)</b>	
Not used	
<b>Resolver (14)</b>	
Not used	
<b>Common to All</b>	
Absolute maximum applied voltage relative to 0V	-9 V to 14 V

<b>11</b>	<b>W, Clock, Not used, Not used</b>
<b>12</b>	<b>W, Clock, Not used, Not used</b>
<b>AB Servo (3), FD Servo(4), FR Servo (5), SC Servo (12)</b>	
Type	EIA 485 differential receivers
Maximum input frequency	512 kHz
Line loading	
Line termination components	120 $\Omega$ (switchable)
Working common mode range	-7 V to +12 V
<b>SC EnDat (9), SC SSI (11)</b>	
Type	Differential voltage
Maximum Signal level	1.25 V peak to peak (sin with regard to sinref and cos with regard to cosref)
Maximum input frequency	See Table 3-11
Maximum applied differential voltage and common mode voltage range	$\pm 4$ V
<b>EnDat (8), SSI (10), BiSS (13)</b>	
Not used	
<b>Resolver (14)</b>	
Not used	
<b>Common to All</b>	
Absolute maximum applied voltage relative to 0V	-9 V to 14 V

### Common to all Feedback types

<b>13</b>	<b>Feedback device supply</b>
Supply voltage	5.15 V $\pm 2$ %, 8 V $\pm 5$ % or 15 V $\pm 5$ %
Maximum output current	300 mA for 5 V and 8 V 200 mA for 15 V
The voltage on Terminal 13 is controlled by Pr <b>03.036</b> . The default for this parameter is 5 V (0) but this can be set to 8 V (1) or 15 V (2). Setting the encoder voltage too high for the encoder could result in damage to the feedback device. The termination resistors should be disabled if the outputs from the encoder are higher than 5 V.	

<b>14</b>	<b>0 V Common</b>
-----------	-------------------

<b>15</b>	<b>Motor thermistor input</b>
Thermistor type is selected in <i>P1 Thermistor Type</i> (03.118).	

### Sincos encoder resolution

The sine wave frequency can be up to 500 kHz but the resolution is reduced at high frequency. Table 3-11 shows the number of bits of interpolated information at different frequencies and with different voltage levels at the drive encoder port. The total resolution in bits per revolution is the ELPR plus the number of bits of interpolated information. Although it is possible to obtain 11 bits of interpolation information, the nominal design value is 10 bits.

**Table 3-11 Feedback resolution based on frequency and voltage level**

Volt/Freq	1 kHz	5 kHz	50 kHz	100 kHz	200 kHz	500 kHz
1.2	11	11	10	10	9	8
1.0	11	11	10	9	9	7
0.8	10	10	10	9	8	7
0.6	10	10	9	9	8	7
0.4	9	9	9	8	7	6

## 3.4 SAFE TORQUE OFF (STO)

The *Unidrive HS70 / HS71* has a single channel STO, whereas the *Unidrive HS72* has a dual channel STO.

### 3.4.1 Single channel SAFE TORQUE OFF (STO) (Unidrive HS70 / HS71)

The SAFE TORQUE OFF function provides a means for preventing the drive from generating torque in the motor, with a very high level of integrity. It is suitable for incorporation into a safety system for a machine. It is also suitable for use as a conventional drive enable input.

The safety function is active when the STO input is in the logic-low state as specified in the control terminal specification. The function is defined according to EN 61800-5-2 and IEC 61800-5-2 as follows. (In these standards a drive offering safety-related functions is referred to as a PDS(SR)):

*'Power, that can cause rotation (or motion in the case of a linear motor), is not applied to the motor. The PDS(SR) will not provide energy to the motor which can generate torque (or force in the case of a linear motor).'*

This safety function corresponds to an uncontrolled stop in accordance with stop category 0 of IEC 60204-1.

The SAFE TORQUE OFF function makes use of the special property of an inverter drive with an induction motor, which is that torque cannot be generated without the continuous correct active behavior of the inverter circuit. All credible faults in the inverter power circuit cause a loss of torque generation.

The SAFE TORQUE OFF function is fail-safe, so when the SAFE TORQUE OFF input is disconnected the drive will not operate the motor, even if a combination of components within the drive has failed. Most component failures are revealed by the drive failing to operate. SAFE TORQUE OFF is also independent of the drive firmware. This meets the requirements of the following standards, for the prevention of operation of the motor.

Data as verified by TÜV Rheinland:

According to EN ISO 13849-1:

PL = e

Category = 4

MTTF<sub>D</sub> = High

DC<sub>av</sub> = High

Mission Time and Proof Test Interval = 20 years

The calculated MTTF<sub>D</sub> for the complete STO function is:

STO1 2574 yr

According to EN 61800-5-2:

SIL = 3

PFH = 4.21 x 10<sup>-11</sup> h<sup>-1</sup>

The SAFE TORQUE OFF input also meets the requirements of EN 81-1 (clause 12.7.3 b) as part of a system for preventing unwanted operation of the motor in a lift (elevator).

SAFE TORQUE OFF can be used to eliminate electro-mechanical contactors, including special safety contactors, which would otherwise be required for safety applications.

The function can be used in safety-related machines or systems which have been designed according to IEC 62061 or IEC 61508, or other standards which are compatible with IEC 61508, since the analysis and the integrity metrics used in EN 61800-5-2 are the same.

**Note on response time of SAFE TORQUE OFF, and use with safety controllers with self-testing outputs.**

SAFE TORQUE OFF has been designed to have a response time of greater than 1 ms, so that it is compatible with safety controllers whose outputs are subject to a dynamic test with a pulse width not exceeding 1 ms.

**Note on the use of servo motors, other permanent-magnet motors, reluctance motors and salient-pole induction motors.**

When the drive is disabled through SAFE TORQUE OFF, a possible (although highly unlikely) failure mode is for two power devices in the inverter circuit to conduct incorrectly.

This fault cannot produce a steady rotating torque in any AC motor. It produces no torque in a conventional induction motor with a cage rotor. If the rotor has permanent magnets and/or saliency, then a transient alignment torque may occur. The motor may briefly try to rotate by up to 180° electrical, for a permanent magnet motor, or 90° electrical, for a salient pole induction motor or reluctance motor. This possible failure mode must be allowed for in the machine design.



The design of safety-related control systems must only be done by personnel with the required training and experience. The SAFE TORQUE OFF function will only ensure the safety of a machine if it is correctly incorporated into a complete safety system. The system must be subject to a risk assessment to confirm that the residual risk of an unsafe event is at an acceptable level for the application.



SAFE TORQUE OFF inhibits the operation of the drive, this includes inhibiting braking. If the drive is required to provide both braking and SAFE TORQUE OFF in the same operation (e.g. for emergency stop) then a safety timer relay or similar device must be used to ensure that the drive is disabled a suitable time after braking. The braking function in the drive is provided by an electronic circuit which is not fail-safe. If braking is a safety requirement, it must be supplemented by an independent fail-safe braking mechanism.



SAFE TORQUE OFF does not provide electrical isolation. The supply to the drive must be disconnected by an approved isolation device before gaining access to power connections.

With SAFE TORQUE OFF there are no single faults in the drive which can permit the motor to be driven. Therefore it is not necessary to have a second channel to interrupt the power connection, nor a fault detection circuit.

It is important to note that a single short-circuit from the SAFE TORQUE OFF input to a DC supply of approximately +24 V would cause the drive to be enabled. This can be excluded under EN ISO 13849-2 by the use of protected wiring. The wiring can be protected by either of the following methods:

- By placing the wiring in a segregated cable duct or other enclosure.
- or
- By providing the wiring with a grounded shield in a positive-logic grounded control circuit. The shield is provided to avoid a hazard from an electrical fault. It may be grounded by any convenient method; no special EMC precautions are required.



**WARNING**

It is essential to observe the maximum permitted voltage of 5 V for a safe low (disabled) state of SAFE TORQUE OFF. The connections to the drive must be arranged so that voltage drops in the 0 V wiring cannot exceed this value under any loading condition. It is strongly recommended that the SAFE TORQUE OFF circuit be provided with a dedicated 0 V conductor which should be connected to terminal 30 at the drive.

**SAFE TORQUE OFF over-ride**

The drive does not provide any facility to over-ride the SAFE TORQUE OFF function, for example for maintenance purposes.

**3.4.2 Dual channel SAFE TORQUE OFF (STO) (Unidrive HS72)**

The SAFE TORQUE OFF function provides a means for preventing the drive from generating torque in the motor, with a very high level of integrity. It is suitable for incorporation into a safety system for a machine. It is also suitable for use as a conventional drive enable input.

The safety function is active when either one or both STO inputs are in the logic-low state as specified in the control terminal specification. The function is defined according to EN 61800-5-2 and IEC 61800-5-2 as follows. (In these standards a drive offering safety-related functions is referred to as a PDS(SR)):

*'Power, that can cause rotation (or motion in the case of a linear motor), is not applied to the motor. The PDS(SR) will not provide energy to the motor which can generate torque (or force in the case of a linear motor).'*

This safety function corresponds to an uncontrolled stop in accordance with stop category 0 of IEC 60204-1.

The SAFE TORQUE OFF function makes use of the special property of an inverter drive with an induction motor, which is that torque cannot be generated without the continuous correct active behavior of the inverter circuit. All credible faults in the inverter power circuit cause a loss of torque generation.

The SAFE TORQUE OFF function is fail-safe, so when the SAFE TORQUE OFF input is disconnected the drive will not operate the motor, even if a combination of components within the drive has failed. Most component failures are revealed by the drive failing to operate. SAFE TORQUE OFF is also independent of the drive firmware. This meets the requirements of the following standards, for the prevention of operation of the motor.

Data as verified by TÜV Rheinland:

According to EN ISO 13849-1:

PL = e

Category = 4

MTTF<sub>D</sub> = High

DC<sub>av</sub> = High

Mission Time and Proof Test Interval = 20 years

The calculated MTTF<sub>D</sub> for the complete STO function is:

STO1 2574 yr

STO2 2716 yr

According to EN 61800-5-2:

SIL = 3

PFH = 4.21 x 10<sup>-11</sup> h<sup>-1</sup>

The SAFE TORQUE OFF input also meets the requirements of EN 81-1 (clause 12.7.3 b) as part of a system for preventing unwanted operation of the motor in a lift (elevator).

SAFE TORQUE OFF can be used to eliminate electro-mechanical contactors, including special safety contactors, which would otherwise be required for safety applications.

The function can be used in safety-related machines or systems which have been designed according to IEC 62061 or IEC 61508, or other standards which are compatible with IEC 61508, since the analysis and the integrity metrics used in EN 61800-5-2 are the same.

**Note on response time of SAFE TORQUE OFF, and use with safety controllers with self-testing outputs.**

SAFE TORQUE OFF has been designed to have a response time of greater than 1 ms, so that it is compatible with safety controllers whose outputs are subject to a dynamic test with a pulse width not exceeding 1 ms.

**Note on the use of servo motors, other permanent-magnet motors, reluctance motors and salient-pole induction motors.**

When the drive is disabled through SAFE TORQUE OFF, a possible (although highly unlikely) failure mode is for two power devices in the inverter circuit to conduct incorrectly.

This fault cannot produce a steady rotating torque in any AC motor. It produces no torque in a conventional induction motor with a cage rotor. If the rotor has permanent magnets and/or saliency, then a transient alignment torque may occur. The motor may briefly try to rotate by up to 180° electrical, for a permanent magnet motor, or 90° electrical, for a salient pole induction motor or reluctance motor. This possible failure mode must be allowed for in the machine design.

**Two-channel SAFE TORQUE OFF**

Two fully independent input channels are provided for the SAFE TORQUE OFF function.

Each input separately meets the requirements of the standards as defined above, regardless of the state of the other input. If either or both inputs are set at a logic low state, there are no single faults in the drive which can permit the motor to be driven.

It is not necessary to use both channels in order for the drive to meet the requirements of the standards. The purpose of the two channels is to allow connection to machine safety systems where two channels are required, and to facilitate protection against wiring faults. For example, if each channel is connected to a safety-related digital output of a safety-related controller, computer or PLC, then on detection of a fault in one output the drive can still be disabled safely through the other output. Then there are no single wiring faults which can cause a loss of the safety function, i.e. inadvertent enabling of the drive.

In the event that the two-channel operation is not required, the two inputs can be connected together to form a single SAFE TORQUE OFF input. In this case it is important to note that a single short-circuit from the SAFE TORQUE OFF input to a DC supply of approximately +24 V would cause the drive to be enabled. This might occur through a fault in the wiring. This can be excluded according to EN ISO 13849-2 by the use of protected wiring. The wiring can be protected by either of the following methods:

- By placing the wiring in a segregated cable duct or other enclosure.
- or**
- By providing the wiring with a grounded shield in a positive-logic grounded control circuit. The shield is provided to avoid a hazard from an electrical fault. It may be grounded by any convenient method; no special EMC precautions are required.

**SAFE TORQUE OFF over-ride**

The drive does not provide any facility to over-ride the SAFE TORQUE OFF function, for example for maintenance purposes. Because of the risk of human error, the installation must not provide any facility to over-ride the function.



**WARNING**

The design of safety-related control systems must only be done by personnel with the required training and experience. The SAFE TORQUE OFF function will only ensure the safety of a machine if it is correctly incorporated into a complete safety system. The system must be subject to a risk assessment to confirm that the residual risk of an unsafe event is at an acceptable level for the application.



**WARNING**

SAFE TORQUE OFF inhibits the operation of the drive, this includes inhibiting braking. If the drive is required to provide both braking and SAFE TORQUE OFF in the same operation (e.g. for emergency stop) then a safety timer relay or similar device must be used to ensure that the drive is disabled a suitable time after braking. The braking function in the drive is provided by an electronic circuit which is not fail-safe. If braking is a safety requirement, it must be supplemented by an independent fail-safe braking mechanism.



**WARNING**

SAFE TORQUE OFF does not provide electrical isolation. The supply to the drive must be disconnected by an approved isolation device before gaining access to power connections.

With SAFE TORQUE OFF there are no single faults in the drive which can permit the motor to be driven. Therefore it is not necessary to have a second channel to interrupt the power connection, nor a fault detection circuit.



**WARNING**

It is essential to observe the maximum permitted voltage of 5 V for a safe low (disabled) state of SAFE TORQUE OFF. The connections to the drive must be arranged so that voltage drops in the 0 V wiring cannot exceed this value under any loading condition. It is strongly recommended that the SAFE TORQUE OFF circuits be provided with a dedicated 0 V conductors which should be connected to terminals 10 and 12 at the drive.

## 4 Getting started

This chapter introduces the user interfaces, menu structure and security levels of the drive.

### 4.1 Understanding the display

The keypad can only be mounted on the drive.

#### 4.1.1 KI-Keypad

The KI-Keypad display consists of two rows of text. The upper row shows the drive status or the menu and parameter number currently being viewed. The lower row of the display line shows the parameter value or the specific trip type. The last two characters on the first row may display special indications. If more than one of these indications is active then the indications are prioritized as shown in Table .

When the drive is powered up the lower row will show the power up parameter defined by *Parameter Displayed At Power-Up* (11.022).

**Figure 4-1 KI-Keypad**

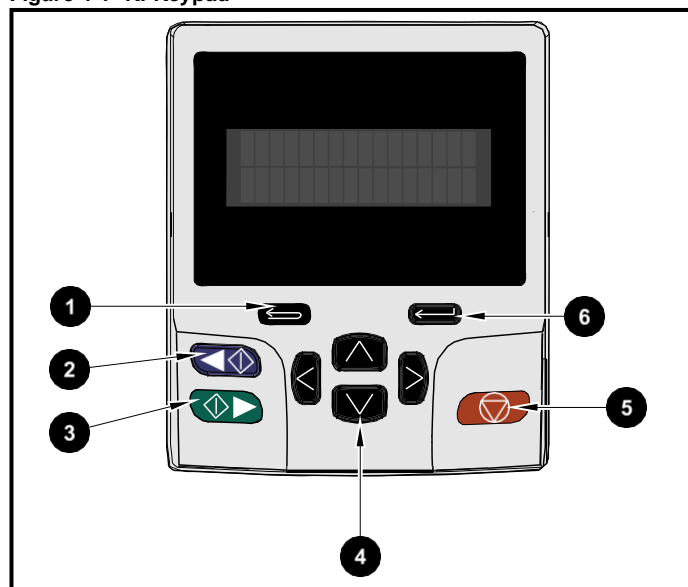

1. Escape button
2. Start reverse (Auxiliary button)
3. Start forward
4. Navigation keys (x4)
5. Stop / Reset (red) button
6. Enter button

**NOTE**









The red stop  button is also used to reset the drive.

The parameter value is correctly displayed in the lower row of the keypad display, see table below.

**Table 4-1 Keypad display formats**

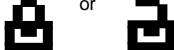
Display formats	Value
IP Address	127.000.000.000
MAC Address	01ABCDEF2345
Time	12:34:56
Date	31-12-11 or 12-31-11
Version number	01.02.02.00
Character	ABCD
32 bit number with decimal point	21474836.47
16 bit binary number	0100001011100101

**Table 4-2 Active action icon**

Active action icon	Description	Priority
	Alarm active	
	Keypad real-time clock battery low	
	Accessing non-volatile media card	
	Drive security active and locked or unlocked	
	Motor map 2 active	
	User program running	
	Keypad reference active	

### 4.2 Keypad operation

#### 4.2.1 Control buttons

The keypad consists of:

- Navigation Keys - Used to navigate the parameter structure and change parameter values.
- Enter / Mode button - Used to toggle between parameter edit and view mode.
- Escape / Exit button - Used to exit from parameter edit or view mode. In parameter edit mode, if parameter values are edited and the exit button pressed the parameter value will be restored to the value it had on entry to edit mode.
- Start forward button - Use to provide a 'Run' command if keypad mode is selected.
- Start reverse button - Used to control the drive if keypad mode is selected and the reverse button is activated. If *Enable Auxiliary Key* (06.013) = 1, then the keypad reference is toggled between run forward and run reverse each time the button is pressed. If *Enable Auxiliary Key* (06.013) = 2, then the button functions as a run reverse key.
- Stop / Reset button - Used to reset the drive. In keypad mode can be used for 'Stop'.

**NOTE**

Low battery voltage is indicated by  low battery symbol on the keypad display. Refer to the *Drive Installation Guide* for information on battery replacement.

Figure 4-2 overleaf shows an example on moving between menus and editing parameters.

Figure 4-2 Display modes

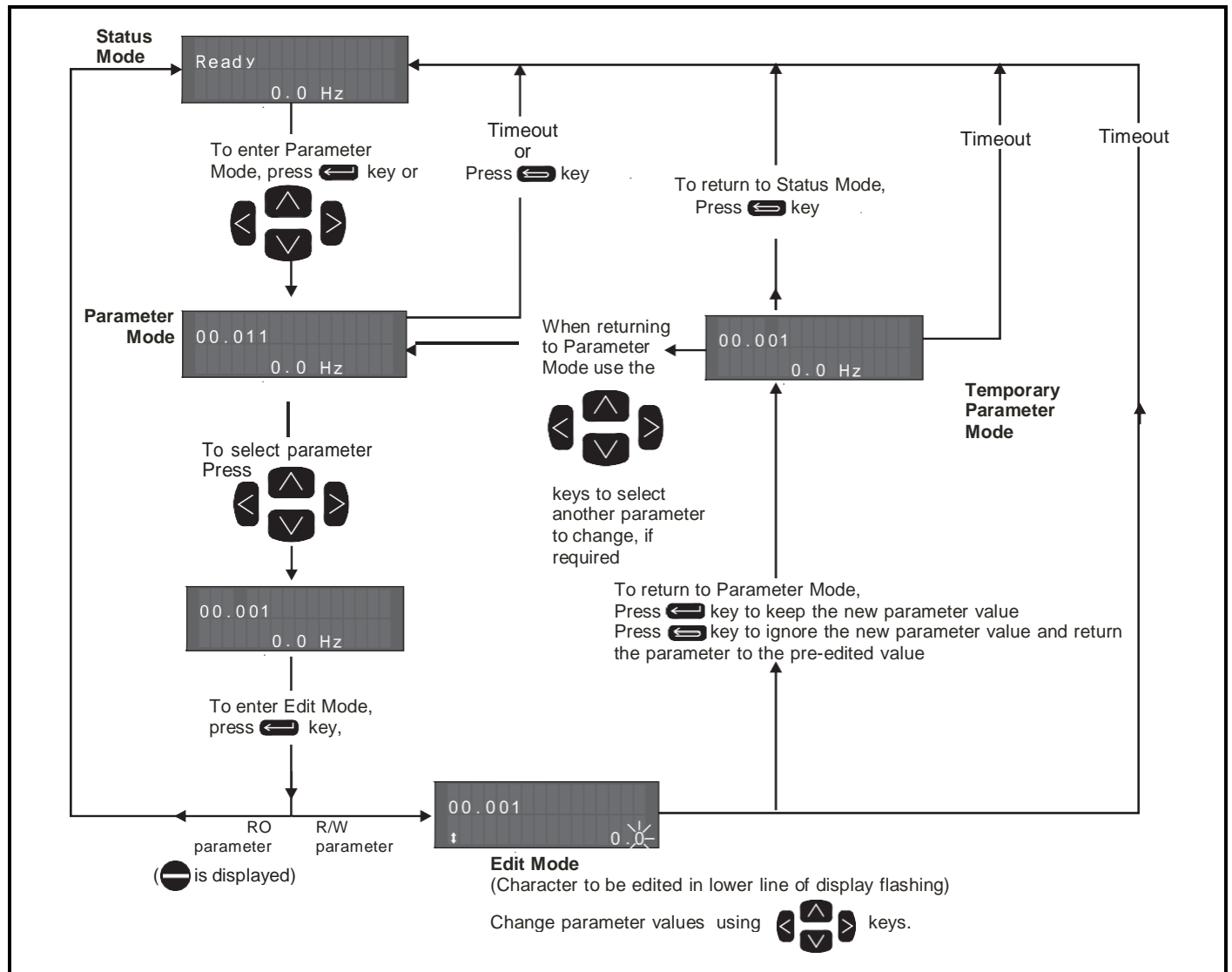

**NOTE**

The navigation keys can only be used to move between menus if Pr 00.049 has been set to show 'All Menus'. Refer to section 4.9 *Parameter access level and security* on page 37.

**4.2.2 Quick access mode**

The quick access mode allows direct access to any parameter without scrolling through menus and parameters.

To enter the quick access mode, press and hold the Enter button on the keypad while in 'parameter mode'.

Figure 4-3 Quick access mode



**4.2.3 Keypad shortcuts**

**In 'parameter mode':**

- If the up and down keypad buttons are pressed together, then the keypad display will jump to the start of the parameter menu being viewed, i.e. Pr 05.005 being viewed, when the above buttons pressed together will jump to Pr 05.000.
- If the left and right keypad buttons are pressed together, then the keypad display will jump to the last viewed parameter in Menu 0.

**In 'parameter edit mode':**

- If the up and down keypad buttons are pressed together, then the parameter value of the parameter being edited will be set to 0.
- If the left and right keypad buttons are pressed together, the least significant digit (furthest right) will be selected on the keypad display for editing.

Figure 4-4 Mode examples

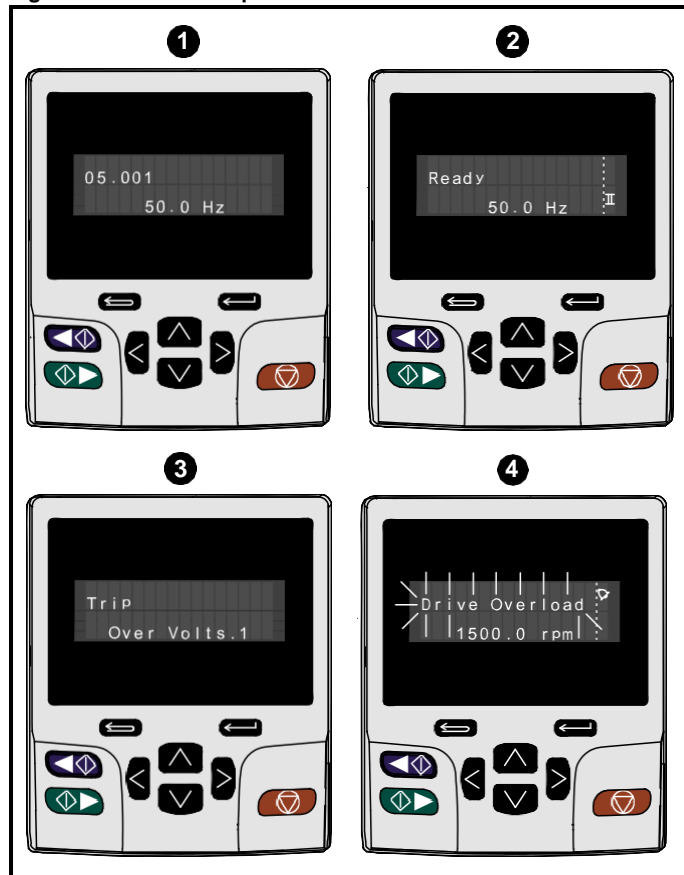

1. Parameter view mode: Read write or Read only

2. Status mode: Drive OK status

If the drive is ok and the parameters are not being edited or viewed, the upper row of the display will show one of the following:

- 'Inhibit', 'Ready' or 'Run'.

3. Status mode: Trip status

When the drive is in trip condition, the upper row of the display will indicate that the drive has tripped and the lower row of the display will show the trip code. For further information regarding trip codes, refer to Table 12-4 *Trip indications* on page 196.

4. Status mode: Alarm status

During an 'alarm' condition the upper row of the display flashes between the drive status (Inhibit, Ready or Run, depending on what is displayed) and the alarm.

Do not change parameter values without careful consideration; incorrect values may cause damage or a safety hazard.

**WARNING**

**NOTE**

When changing the values of parameters, make a note of the new values in case they need to be entered again.

**NOTE**

For new parameter-values to apply after the line power supply to the drive is interrupted, new values must be saved. Refer to section 4.7 *Saving parameters* on page 37.

### 4.3 Menu structure

The drive parameter structure consists of menus and parameters.

The drive initially powers up so that only Menu 0 can be viewed. The up and down arrow buttons are used to navigate between parameters and once Pr 00.049 has been set to 'All Menus' the left and right buttons are used to navigate between menus. For further information, refer to section 4.9 *Parameter access level and security* on page 37

Figure 4-5 Parameter navigation

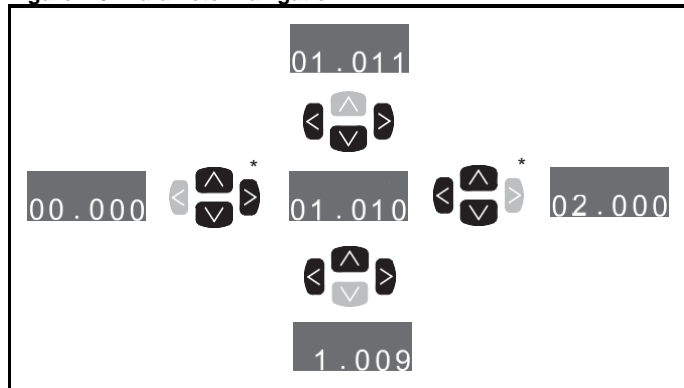

\* Can only be used to move between menus if all menus have been enabled (Pr 00.049). Refer to section 4.9 *Parameter access level and security* on page 37.

The menus and parameters roll over in both directions.

i.e. if the last parameter is displayed, a further press will cause the display to rollover and show the first parameter.

When changing between menus the drive remembers which parameter was last viewed in a particular menu and thus displays that parameter.

Figure 4-6 Menu structure

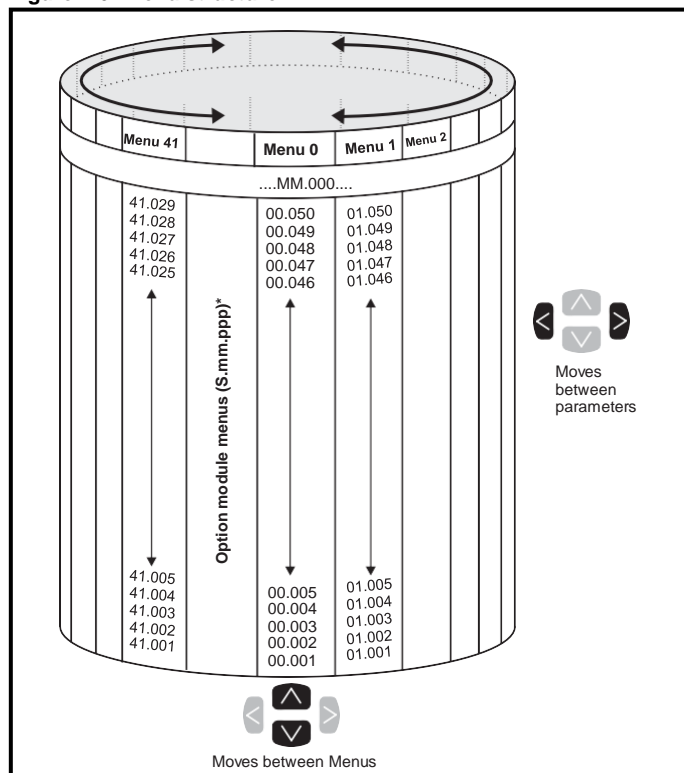

\* The option module menus (S.mm.ppp) are only displayed if option modules are installed. Where S signifies the option module slot number and the mm.ppp signifies the menu and the parameter number of the option module's internal menus and parameter.

## 4.4 Menu 0

Menu 0 is used to bring together various commonly used parameters for basic easy set up of the drive. The parameters displayed in Menu 0 can be configured in Menu 22.

Appropriate parameters are copied from the advanced menus into Menu 0 and thus exist in both locations.

For further information, refer to Chapter 5 *Basic parameters* on page 41.

**Figure 4-7 Menu 0 copying**

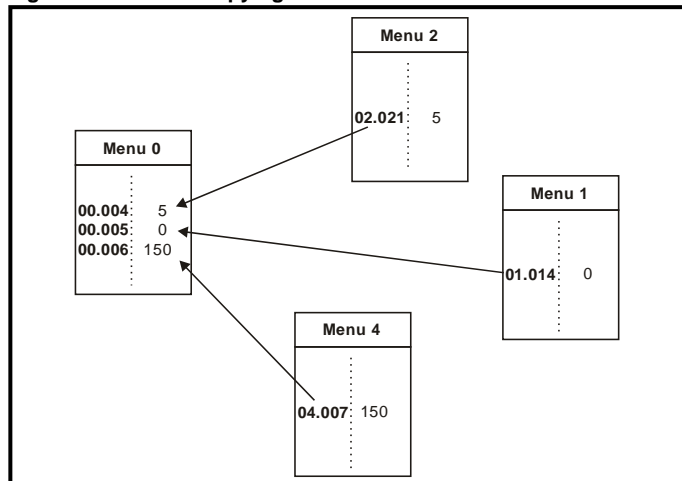

## 4.5 Advanced menus

The advanced menus consist of groups or parameters appropriate to a specific function or feature of the drive. Menus 0 to 41 can be viewed on the KI-Keypad.

The option module menus (S.mm.ppp) are only displayed (except for *Unidrive HS70 / HS72* 4.mm.ppp) if option modules are installed. Where S signifies the option module slot number and the mm.ppp signifies the menu and parameter number of the option module's internal menus and parameter.

On *Unidrive HS70 / HS72*, menu 4.00.xxx is the same as menu 24.xxx.

**Table 4-3 Advanced menu descriptions**



Menu	Description
0	Commonly used basic set up parameters for quick / easy programming
1	Frequency / Speed reference
2	Ramps
3	Frequency slaving, speed feedback and speed control
4	Torque and current control
5	Motor control
6	Sequencer and clock
7	Analog I/O
8	Digital I/O
9	Programmable logic, motorized pot, binary sum, timers and scope
10	Status and trips
11	Drive set-up and identification, serial communications
12	Threshold detectors and variable selectors
13	Standard motion control
14	User PID controller
15	Option module slot 1 set-up menu
16	Option module slot 2 set-up menu
17	Option module slot 3 set-up menu
18	General option module application menu 1
19	General option module application menu 2
20	General option module application menu 3
21	Second motor parameters
22	Menu 0 set-up
23	Not allocated
24	Ethernet module (slot 4) set-up menu*
25	Option module slot 1 application parameters
26	Option module slot 2 application parameters
27	Option module slot 3 application parameters
28	Option module slot 4 application parameters
29	Reserved menu
30	Onboard user programming application menu
31-41	Advanced motion controller set-up parameters
Slot 1	Slot 1 option menus**
Slot 2	Slot 2 option menus**
Slot 3	Slot 3 option menus**
Slot 4	Slot 4 option menus**

\* Only displayed on *Unidrive HS70 / HS72*.

\*\* Only displayed when the option modules are installed.

### 4.5.1 KI-Keypad set-up menu

To enter the keypad set-up menu press and hold the escape  button on the keypad from status mode. All the keypad parameters are saved to the keypad non-volatile memory when exiting from the keypad set-up menu.

To exit from the keypad set-up menu press the escape  or  or  button. Below are the keypad set-up parameters.

**Table 4-4 KI-Keypad set-up parameters**

Parameters		Range	Type
Keypad.00	Language	Classic English (0) English (1),	RW
Keypad.01	Show Units	Off (0), On (1)	RW
Keypad.02	Backlight Level	0 to 100 %	RW
Keypad.03	Keypad Date	01.01.10 to 31.12.99	RO
Keypad.04	Keypad Time	00:00:00 to 23:59:59	RO
Keypad.05	Show Raw Text Parameter Values	Off (0), On (1)	RW
Keypad.06	Software Version	00.00.00.00 to 99.99.99.99	RO

**NOTE**

It is not possible to access the keypad parameters via any communications channel.

### 4.5.2 Display messages

The following tables indicate the various possible mnemonics which can be displayed by the drive and their meaning.

**Table 4-5 Status indications**

Upper row string	Description	Drive output stage
<b>Inhibit</b>	The drive is inhibited and cannot be run. The SAFE TORQUE OFF signal is not applied to SAFE TORQUE OFF terminals or Pr <b>06.015</b> is set to 0. The other conditions that can prevent the drive from enabling are shown as bits in <i>Enable Conditions</i> (06.010)	Disabled
<b>Ready</b>	The drive is ready to run. The drive enable is active, but the drive inverter is not active because the final drive run is not active	Disabled
<b>Stop</b>	The drive is stopped / holding zero speed.	Enabled
<b>Run</b>	The drive is active and running	Enabled
<b>Scan</b>	The drive is enabled in Regen mode and is trying to synchronize to the supply	Enabled
<b>Supply Loss</b>	Supply loss condition has been detected	Enabled
<b>Deceleration</b>	The motor is being decelerated to zero speed / frequency because the final drive run has been deactivated.	Enabled
<b>dc injection</b>	The drive is applying dc injection braking	Enabled
<b>Position</b>	Positioning / position control is active during an orientation stop	Enabled
<b>Trip</b>	The drive has tripped and no longer controlling the motor. The trip code appears in the lower display.	Disabled
<b>Active</b>	The Regen unit is enabled and synchronized to the supply	Enabled
<b>Under Voltage</b>	The drive is in the under voltage state either in low voltage or high voltage mode.	Disabled

### 4.5.3 Alarm indications

An alarm is an indication given on the display by alternating the alarm string with the drive status string on the upper row and showing the alarm symbol in the last character in the upper row. Alarms strings are not displayed when a parameter is being edited, but the user will still see the alarm character on the upper row.

**Table 4-6 Alarm indications**

Alarm string	Description
<b>Brake Resistor</b>	Brake resistor overload. <i>Braking Resistor Thermal Accumulator</i> (10.039) in the drive has reached 75.0 % of the value at which the drive will trip.
<b>Motor Overload</b>	<i>Motor Protection Accumulator</i> (04.019) in the drive has reached 75.0 % of the value at which the drive will trip and the load on the drive is >100 %.
<b>Ind Overload</b>	Regen inductor overload. <i>Inductor Protection Accumulator</i> (04.019) in the drive has reached 75.0 % of the value at which the drive will trip and the load on the drive is >100 %.
<b>Drive Overload</b>	Drive over temperature. <i>Percentage Of Drive Thermal Trip Level</i> (07.036) in the drive is greater than 90 %.
<b>Auto Tune</b>	The autotune procedure has been initialized and an autotune in progress.
<b>Limit Switch</b>	Limit switch active. Indicates that a limit switch is active and that is causing the motor to be stopped.

**Table 4-7 Option module and NV media card and other status indications at power-up**

First row string	Second row string	Status
<b>Booting</b>	<b>Parameters</b>	Parameters are being loaded
Drive parameters are being loaded from a NV Media Card		
<b>Booting</b>	<b>User Program</b>	User program being loaded
User program is being loaded from a NV Media Card to the drive		
<b>Booting</b>	<b>Option Program</b>	User program being loaded
User program is being loaded from a NV Media Card to the option module in slot X		
<b>Writing To</b>	<b>NV Card</b>	Data being written to NV Media Card
Data is being written to a NV Media Card to ensure that its copy of the drive parameters is correct because the drive is in Auto or Boot mode		
<b>Waiting For</b>	<b>Power System</b>	Waiting for power stage
The drive is waiting for the processor in the power stage to respond after power-up		
<b>Waiting For</b>	<b>Options</b>	Waiting for an option module
The drive is waiting for the options modules to respond after power-up		
<b>Uploading From</b>	<b>Options</b>	Loading parameter database
At power-up it may be necessary to update the parameter database held by the drive because an option module has changed or because an applications module has requested changes to the parameter structure. This may involve data transfer between the drive an option modules. During this period 'Uploading From Options' is displayed		

## 4.6 Changing the operating mode

Changing the operating mode returns all parameters to their default value, including the motor parameters. *User security status* (00.049) and *User security code* (00.034) are not affected by this procedure).

### Procedure

Use the following procedure only if a different operating mode is required:

1. Ensure the drive is not enabled, i.e. terminal 31 on *Unidrive HS70 / HS71* and terminal 11 & 13 on *Unidrive HS72* is open or Pr **06.015** is Off (0)
2. Enter either of the following values in Pr **mm.000**, as appropriate:  
1253 (50 Hz AC supply frequency)  
1254 (60 Hz AC supply frequency)
3. Change the setting of Pr **0.048** as follows:

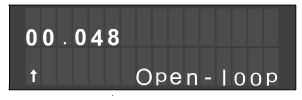
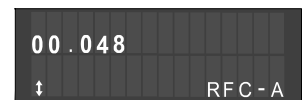
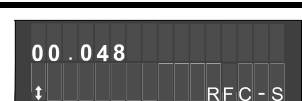
Pr 00.048 setting	Operating mode
	1 Open-loop
	2 RFC-A
	3 RFC-S

The figures in the second column apply when serial communications are used.

4. Either:
  - Press the red  reset button
  - Toggle the reset digital input
  - Carry out a drive reset through serial communications by setting Pr **10.038** to 100.

### NOTE

Entering 1253 or 1254 in Pr **mm.000** will only load defaults if the setting of Pr **00.048** has been changed.

## 4.7 Saving parameters

When changing a parameter in Menu 0, the new value is saved when pressing the  Enter button to return to parameter view mode from parameter edit mode.

If parameters have been changed in the advanced menus, then the change will not be saved automatically. A save function must be carried out.

### Procedure

1. Select 'Save Parameters\*' in Pr **mm.000** (alternatively enter a value of 1000\* in Pr **mm.000**)
2. Either:
  - Press the red  reset button
  - Toggle the reset digital input, or
  - Carry out a drive reset through serial communications by setting Pr **10.038** to 100

\* If the drive is in the under voltage state (i.e. when the control terminal 1 & 2 are being supplied from a low voltage DC supply) a value of 1001 must be entered into Pr **mm.000** to perform a save function.

## 4.8 Restoring parameter defaults

Restoring parameter defaults by this method saves the default values in the drives memory. *User security status* (00.049) and *User security code* (00.034) are not affected by this procedure).

### Procedure

1. Ensure the drive is not enabled, i.e. terminal 31 on *Unidrive HS70 / HS71* and terminal 11 & 13 on *Unidrive HS72* is open or Pr **06.015** is Off (0)
2. Select 'Reset 50 Hz Defs' or 'Reset 60 Hz Defs' in Pr **mm.000**. (alternatively, enter 1233 (50 Hz settings) or 1244 (60 Hz settings) in Pr **mm.000**).
3. Either:
  - Press the red  reset button
  - Toggle the reset digital input
  - Carry out a drive reset through serial communications by setting Pr **10.038** to 100

## 4.9 Parameter access level and security

The parameter access level determines whether the user has access to Menu 0 only or to all the advanced menus (Menus 1 to 41) in addition to Menu 0.

The User Security determines whether the access to the user is read only or read write.

Both the User Security and Parameter Access Level can operate independently of each other as shown in Table 4-8.

**Table 4-8 Parameter access level and security**

User security status (11.044)	Access level	User security	Menu 0 status	Advanced menu status
0	Menu 0	Open	RW	Not visible
		Closed	RO	Not visible
1	All Menus	Open	RW	RW
		Closed	RO	RO
2	Read-only Menu 0	Open	RO	Not visible
		Closed	RO	Not visible
3	Read-only	Open	RO	RO
		Closed	RO	RO
4	Status only	Open	Not visible	Not visible
		Closed	Not visible	Not visible
5	No access	Open	Not visible	Not visible
		Closed	Not visible	Not visible

The default settings of the drive are Parameter Access Level Menu 0 and user Security Open i.e. read / write access to Menu 0 with the advanced menus not visible.

### 4.9.1 User Security Level / Access Level

The drive provides a number of different levels of security that can be set by the user via *User Security Status* (11.044); these are shown below.

User Security Status (Pr 11.044)	Description
Menu 0 (0)	All writable parameters are available to be edited but only parameters in Menu 0 are visible
All menus (1)	All parameters are visible and all writable parameters are available to be edited
Read-only Menu 0 (2)	Access is limited to Menu 0 parameters only. All parameters are read-only
Read-only (3)	All parameters are read-only however all menus and parameters are visible
Status only (4)	The keypad remains in status mode and no parameters can be viewed or edited
No access (5)	The keypad remains in status mode and no parameters can be viewed or edited. Drive parameters cannot be accessed via a comms/ fieldbus interface in the drive or any option module

## 4.9.2 Changing the User Security Level /Access Level

The security level is determined by the setting of Pr **00.049** or Pr **11.044**. The Security Level can be changed through the keypad even if the User Security Code has been set.

### 4.9.3 User Security Code

The User Security Code, when set, prevents write access to any of the parameters in any menu.

#### Setting User Security Code

Enter a value between 1 and 2147483647 in Pr **00.034** and press the

 button; the security code has now been set to this value. In order to activate the security, the Security level must be set to desired level in Pr **00.049**. When the drive is reset, the security code will have been

activated and the drive returns to Menu 0 and the  symbol is displayed in the right hand corner of the keypad display. The value of Pr **00.034** will return to 0 in order to hide the security code.

#### Unlocking User Security Code

Select a parameter that need to be edited and press the  button, the upper display will now show 'Security Code'. Use the arrow buttons

to set the security code and press the  button. With the correct security code entered, the display will revert to the parameter selected in edit mode.

If an incorrect security code is entered, the following message 'Incorrect security code' is displayed, then the display will revert to parameter view mode.

#### Disabling User Security

Unlock the previously set security code as detailed above. Set Pr **00.034**

to 0 and press the  button. The User Security has now been disabled, and will not have to be unlocked each time the drive is powered up to allow read / write access to the parameters.

## 4.10 Displaying parameters with non-default values only

By selecting 'Show non-default' in Pr **mm.000** (Alternatively, enter 12000 in Pr **mm.000**), the only parameters that will be visible to the user will be those containing a non-default value. This function does not require a drive reset to become active. In order to deactivate this function, return to Pr **mm.000** and select 'No action' (alternatively enter a value of 0). Please note that this function can be affected by the access level enabled, refer to section 4.9 *Parameter access level and security* on page 37 for further information regarding access level.

## 4.11 Displaying destination parameters only

By selecting 'Destinations' in Pr **mm.000** (Alternatively enter 12001 in Pr **mm.000**), the only parameters that will be visible to the user will be destination parameters. This function does not require a drive reset to become active. In order to deactivate this function, return to Pr **mm.000** and select 'No action' (alternatively enter a value of 0).

Please note that this function can be affected by the access level enabled, refer to section 4.9 *Parameter access level and security* on page 37 for further information regarding access level.

## 4.12 Communications

The *Unidrive HS70 / HS72* drive offer Ethernet fieldbus communications and the *Unidrive HS71* drive offers a 2 wire 485 interface. This enables the drive set-up, operation and monitoring to be carried out with a PC or controller if required.

### 4.12.1 Unidrive HS70 / HS72 - Ethernet communications

The drive offers fieldbus communications via Ethernet, this enables the drive set-up, operation and monitoring to be carried out with a PC or controller. The drive provides two RJ45 connections with an Ethernet switch for easy network creation. The Ethernet option provides support for the following protocols:

- Modbus TCP
- EtherNet/IP
- Web pages\*
- Email\*
- Synchronization with IEEE 1588

\*Features have not been implemented but will be available soon.

In addition to two RJ45 connectors, each port provides a status LED for diagnostic / information purposes.

LED status	Description
Off	Ethernet connection not detected
Solid green	Ethernet connection detected but no data
Flashing green	Ethernet connection detected and data flow

Figure 4-8 Location of the Ethernet ports

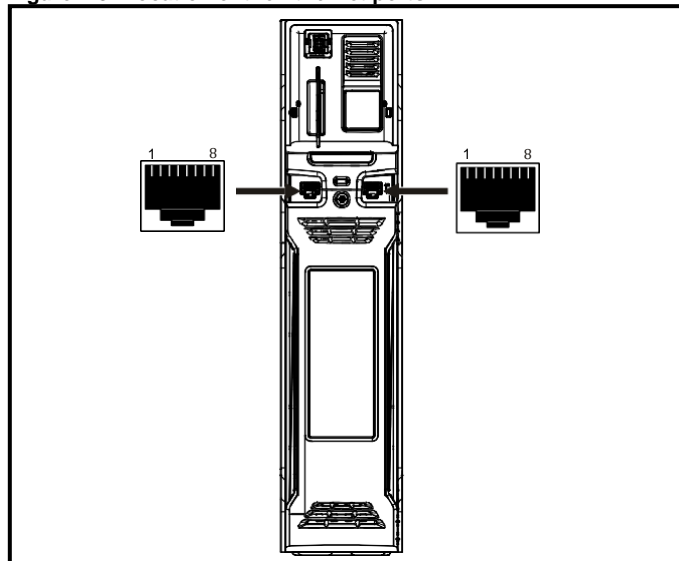

#### NOTE

The shell of the RJ45 connector is isolated from the 0 V of the drive control terminals but it is connected to ground.

#### Recommended cable

It is recommended that a minimum specification of CAT5e is used in new installations. If the existing cabling is used this may limit the maximum data rate depending on the cable ratings. In noisy environments the use of STP cable will offer additional noise immunity.

#### Maximum network lengths

The main restriction imposed on the Ethernet cabling is the length of a single segment of the cable, for Copper - UTP/STP CAT 5 cable type, maximum trunk cable length should be limited to 100 m. If distances greater than this are required it may be possible to extend the network with additional switches.

## Ethernet set-up parameters

The following section covers the minimum number of parameters required to be set to establish an Ethernet communication.

**Table 4-9 Key to parameter table coding**

RW	Read / Write	ND	No default value
RO	Read only	NC	Not copied
Num	Number parameter	PT	Protected parameter
Bit	Bit parameter	RA	Rating dependant
Txt	Text string	US	User save
Bin	Binary parameter	PS	Power-down save
FI	Filtered	DE	Destination
IP	IP Address	Mac	Mac Address
Date	Date parameter	Time	Time parameter
Chr	Character parameter		

<b>4.00.007</b> {24.007}	<b>Reset</b>												
RW	Bit											US	
⇅		Off (0) or On (1)						⇒	Off (0)				

Changes to the Ethernet set-up parameters will not take effect until a *Reset* (4.00.007) has been performed.

<b>4.00.010</b>	<b>Active IP Address</b>												
RO	IP											US	
⇅		000.000.000.000 to 255.255.255.255						⇒					

This parameter displays the Active IP Address. The Active IP Address can also be viewed in Pr **00.037**.

<b>4.02.005</b>	<b>DHCP Enable</b>												
RW	Bit											US	
⇅		Off (0) or On (1)						⇒	On (1)				

If *DHCP Enable* (4.02.005) is set to On (1), the IP address is acquired from the DHCP server and written to *IP Address* (4.02.006).

### NOTE

When using manual / static IP address configuration, ensure *Subnet Mask* (4.02.007) and *Default Gateway* (4.02.008) should also be set manually.

<b>4.02.006</b>	<b>IP Address</b>												
RW	IP											US	
⇅		000.000.000.000 to 255.255.255.255						⇒	192.168.001.100				

This parameter controls and displays the IP address of the drive. If *DHCP Enable* (4.02.005) is set to On (1) this parameter will become read-only.

<b>4.02.007</b>	<b>Subnet Mask</b>												
RW	IP											US	
⇅		000.000.000.000 to 255.255.255.255						⇒	255.255.255.000				

This parameter controls and displays the *Subnet Mask* (4.02.007) of the drive.

<b>4.02.008</b>	<b>Default Gateway</b>												
RW	IP											US	
⇅		000.000.000.000 to 255.255.255.255						⇒	192.168.1.254				

This parameter controls and displays the *Default Gateway* (4.02.008) of the drive.

### PC Tools support

The discovery protocol feature, which is supported by the Unidrive HS PC tools, is able to discover the drives that are connected to a PC, independent of above parameter settings.

### 4.12.2 Unidrive HS71 - 485 Serial communications

The EIA485 option provides two parallel RJ45 connectors allowing easy daisy chaining. The drive only supports Modbus RTU protocol.

The serial communications port of the drive is a RJ45 socket, which is isolated from the power stage and the other control terminals (see section 3.1 *Communications connections* on page 15 for connection and isolation details).

The communications port applies a 2 unit load to the communications network.

### USB/EIA232 to EIA485 Communications

An external USB/EIA232 hardware interface such as a PC cannot be used directly with the 2-wire EIA485 interface of the drive. Therefore a suitable converter is required.

Suitable USB to EIA485 and EIA232 to EIA485 isolated converters are available from Control Techniques as follows:

- CT USB Comms cable (CT Part No. 4500-0096)
- CT EIA232 Comms cable (CT Part No. 4500-0087)

### NOTE

When using the CT EIA232 Comms cable the available baud rate is limited to 19.2 k baud.

When using one of the above converters or any other suitable converter with the drive, it is recommended that no terminating resistors be connected on the network. It may be necessary to 'link out' the terminating resistor within the converter depending on which type is used. The information on how to link out the terminating resistor will normally be contained in the user information supplied with the converter.

### Serial communications set-up parameters

The following parameters need to be set according to the system requirements.

Serial communications set-up parameters		
<p><i>Serial Mode</i> (11.024) {00.035}</p>	<p>8 2 NP (0), 8 1 NP (1), 8 1 EP (2), 8 1 OP (3), 8 2 NP M (4), 8 1 NP M (5), 8 1 EP M (6), 8 1 OP M (7), 7 2 NP (8), 7 1 NP (9), 7 1 EP (10), 7 1 OP (11), 7 2 NP M (12), 7 1 NP M (13), 7 1 EP M (14), 7 1 OP M (15)</p>	<p>The drive only supports the Modbus RTU protocol and is always a slave. This parameter defines the supported data formats used by the 485 comms port (if installed) on the drive. This parameter can be changed via the drive keypad, via a option module or via the comms interface itself.</p>
<p><i>Serial Baud Rate</i> (11.025) {00.036}</p>	<p>300 (0), 600 (1), 1200 (2), 2400 (3), 4800 (4), 9600 (5), 19200 (6), 38400 (7), 57600(8), 76800(9), 115200 (10)</p>	<p>This parameter can be changed via the drive keypad, via a option module or via the comms interface itself. If it is changed via the comms interface, the response to the command uses the original baud rate. The master should wait at least 20 ms before sending a new message using the new baud rate.</p>
<p><i>Serial Address</i> (11.023) {00.037}</p>	<p>1 to 247</p>	<p>This parameter defines the serial address and an addresses between 1 and 247 are permitted.</p>

## 5 Basic parameters

Menu 0 is used to bring together various commonly used parameters for basic easy set up of the drive. All the parameters in Menu 0 appear in other menus in the drive (denoted by {...}). Menus 22 can be used to configure the parameters in Menu 0.

### 5.1 Menu 0: Basic parameters

Parameter	Range			Default			Type							
	OL	RFC-A	RFC-S	OL	RFC-A	RFC-S								
00.001	Minimum Reference Clamp	{01.007}	±VM_NEGATIVE_REF_CLAMP1 Hz / rpm			0.0 Hz	0.0 rpm		RW	Num			US	
00.002	Maximum Reference Clamp	{01.006}	±VM_POSITIVE_REF_CLAMP1 Hz / rpm			50 Hz default: 50.0 Hz 60 Hz default: 60.0 Hz	50 Hz default: 1500.0 rpm 60 Hz default: 1800.0 rpm	3000.0 rpm	RW	Num			US	
00.003	Acceleration Rate 1	{02.011}	±VM_ACCEL_RATE			5.0 s/100 Hz	2.000 s/1000 rpm	0.200 s/1000 rpm	RW	Num			US	
00.004	Deceleration Rate 1	{02.021}	±VM_ACCEL_RATE			10.0 s/100 Hz	2.000 s/1000 rpm	0.200 s/1000 rpm	RW	Num			US	
00.005	Reference Selector	{01.014}	A1 A2 (0), A1 Preset (1), A2 Preset (2), Preset (3), Keypad (4), Precision (5), Keypad Ref (6)			A1 A2 (0) / Preset (3)***			RW	Txt			US	
00.006	Symmetrical Current Limit	{04.007}	±VM_MOTOR1_CURRENT_LIMIT %			165 %	175 %		RW	Num		RA	US	
00.007	Open-loop Control Mode	{05.014}	Ur S (0), Ur I (1), Fixed (2), Ur Auto (3), Ur I (4), Square (5), Current 1P (6)			Ur I (4)			RW	Txt			US	
	Speed Controller Proportional Gain Kp1	{03.010}					0.0300 s/rad	0.0100 s/rad	RW	Num			US	
00.008	Low Frequency Voltage Boost	{05.015}	0.0 to 25.0 %			3.0 %			RW	Num			US	
	Speed Controller Integral Gain Ki1	{03.011}					0.10 s <sup>2</sup> /rad	1.00 s <sup>2</sup> /rad	RW	Num			US	
00.009	Dynamic V to F Select	{05.013}	Off (0) or On (1)			Off (0)			RW	Bit			US	
	Speed Controller Differential Feedback Gain Kd 1	{03.012}					0.00000 to 0.65535 1/rad		RW	Num			US	
00.010	Motor Rpm	{05.004}	±180000 rpm			0 rpm			RW	Bit			US	
	Speed Feedback	{03.002}	±VM_SPEED rpm						RO	Num	ND	NC	PT	FI
00.011	Output Frequency	{05.001}	±VM_SPEED_FREQ_REF Hz						RO	Num	ND	NC	PT	FI
	P1 Position	{03.029}				0 to 65535			RO	Num	ND	NC	PT	FI
00.012	Current Magnitude	{04.001}	±VM_DRIVE_CURRENT_UNIPOLAR A						RO	Bit	ND	NC	PT	FI
00.013	Torque Producing Current	{04.002}	±VM_DRIVE_CURRENT A						RO	Bit	ND	NC	PT	FI
00.014	Torque Mode Selector	{04.011}	0 or 1	0 to 5		0			RW	Num			US	
00.015	Ramp Mode Select	{02.004}	Fast (0), Standard (1), Std boost (2)	Fast (0), Standard (1)		Standard (1)			RW	Txt			US	
00.016	Ramp Enable	{02.002}	Off (0) or On (1)			On (1)			RW	Bit			US	
00.017	Digital Input 6 Destination****	{08.026}	00.000 to 59.999			06.031			RW	Num	DE		PT	US
	Current Reference Filter Time Constant	{04.012}	0.0 to 25.0 ms			0.0 ms			RW	Num			US	
00.019	Analog Input 2 Mode****	{07.011}	4-20 mA Low (-4), 20-4 mA Low (-3), 4-20 mA Hold (-2), 20-4 mA Hold (-1), 0-20 mA (0), 20-0 mA (1), 4-20 mA Trip (2), 20-4 mA Trip (3), 4-20 mA (4), 20-4 mA (5), Volt (6)			Volt (6)			RW	Txt			US	
00.020	Analog Input 2 Destination****	{07.014}	00.000 to 59.999			01.037			RW	Num	DE		PT	US
00.021	Analog Input 3 Mode****	{07.015}	Volt (6), Therm Short Cct (7), Thermistor (8), Therm No Trip (9)			Volt (6)			RW	Txt			US	
00.022	Bipolar Reference Enable	{01.010}	Off (0) or On (1)			Off (0)			RW	Bit			US	
00.023	Jog Reference	{01.005}	0.0 to 400.0 Hz	0.0 to 4000.0 rpm		0.0			RW	Num			US	
00.024	Preset Reference 1	{01.021}	±VM_SPEED_FREQ_REF rpm			0.0			RW	Num			US	
00.025	Preset Reference 2	{01.022}	±VM_SPEED_FREQ_REF rpm			0.0			RW	Num			US	
00.026	Preset Reference 3	{01.023}	±VM_SPEED_FREQ_REF Hz			0.0			RW	Num			US	
	Overspeed Threshold	{03.008}	0 to 50000 rpm			0.0			RW	Num			US	
00.027	Preset Reference 4	{01.024}	±VM_SPEED_FREQ_REF Hz			0.0			RW	Num			US	
	P1 Rotary Lines Per Revolution	{03.034}	1 to 100000			1024			4096	RW	Num			US
00.028	Enable Auxiliary Key	{06.013}	0 to 2			0			RW	Num			US	
00.029	NV Media Card Data Previously Loaded	{11.036}	0 to 999						RO	Num		NC	PT	
00.030	Parameter Cloning	{11.042}	None (0), Read (1), Program (2), Auto (3), Boot (4)			None (0)			RW	Txt		NC	US	
00.031	Drive Rated Voltage	{11.033}	200 V (0), 400 V (1), 575 V (2), 690 V (3)						RO	Txt	ND	NC	PT	
00.032	Maximum Heavy Duty Rating	{11.032}	0.000 to 99999.999 A						RO	Num	ND	NC	PT	

Parameter			Range			Default			Type					
			OL	RFC-A	RFC-S	OL	RFC-A	RFC-S						
00.0033	Catch A Spinning Motor	{06.009}	Disable (0), Enable (1), Fwd Only (2), Rev Only (3)			Disable (0)			RW	Txt				US
	Motor Parameter Adaptive Control	{05.016}	0 to 2			0			RW	Num				US
00.0034	User Security Code	{11.030}	0 to 2 <sup>31</sup> -1			0			RW	Num	ND	NC	PT	US
00.0035	Serial Mode*	{11.024}	8 2 NP (0), 8 1 NP (1), 8 1 EP (2), 8 1 OP (3), 8 2 NP M (4), 8 1 NP M (5), 8 1 EP M (6), 8 1 OP M (7), 7 2 NP (8), 7 1 NP (9), 7 1 EP (10), 7 1 OP (11), 7 2 NP M (12), 7 1 NP M (13), 7 1 EP M (14), 7 1 OP M (15)			8 2 NP (0)			RW	Txt				US
00.0036	Serial Baud Rate*	{11.025}	300 (0), 600 (1), 1200 (2), 2400 (3), 4800 (4), 9600 (5), 19200 (6), 38400 (7), 57600 (8), 76800 (9), 115200 (10)			19200 (6)			RW	Txt				US
00.0037	Serial Address*	{11.023}	1 to 247			1			RW	Num				US
00.0037	Active IP Address**	{24.010}	000.000.000.000 to 255.255.255.255						RO	IP		NC	PT	
00.0038	Current Controller Kp Gain	{04.013}	0 to 30000			20   150			RW	Num				US
00.0039	Current Controller Ki Gain	{04.014}	0 to 30000			40   2000			RW	Num				US
00.0040	Auto-tune	{05.012}	0 to 2	0 to 5	0 to 6	0			RW	Num		NC		
00.0041	Maximum Switching Frequency	{05.018}	2 kHz (0), 3 kHz (1), 4 kHz (2), 6 kHz (3), 8 kHz (4), 12 kHz (5), 16 kHz (6)			3 kHz (1)   6 kHz (3)			RW	Txt		RA		US
00.0042	Number Of Motor Poles	{05.011}	Automatic (0) to 480 Poles (240)			Automatic (0)   6 Poles (3)			RW	Num				US
00.0043	Rated Power Factor	{05.010}	0.000 to 1.000			0.850			RW	Num		RA		US
	Position Feedback Phase Angle	{03.025}	0.0 to 359.9 °						RW	Num	ND			US
00.0044	Rated Voltage	{05.009}	±VM_AC_VOLTAGE_SET			200 V drive: 230 V 50 Hz default 400V drive: 400 V 60 Hz default 400V drive: 460 V 575 V drive: 575 V 690 V drive: 690 V			RW	Num		RA		US
00.0045	Rated Speed	{05.008}	0 to 180000 rpm	0.00 to 50000.00 rpm		50 Hz default: 1500 rpm 60 Hz default: 1800rpm	50 Hz default: 1450 rpm 60 Hz default: 1750rpm	RW	Num				US	
	Motor Thermal Time Constant 1	{04.015}	1.0 to 3000.0 s			89.0 s			RW	Num				US
00.0046	Rated Current	{05.007}	±VM_RATED_CURRENT			Maximum Heavy Duty Rating (11.032)			RW	Num		RA		US
00.0047	Rated Frequency	{05.006}	0.0 to 3000.0 Hz	0.0 to 1667.0 Hz		50 Hz default: 50.0 Hz 60 Hz default: 60.0 Hz		RW	Num				US	
00.0048	Drive Mode	{11.031}	Open-loop (1), RFC-A (2), RFC-S (3), Regen (4)			Open-loop (1)   RFC-A (2)   RFC-S (3)			RW	Txt	ND	NC	PT	
00.0049	User Security Status	{11.044}	Menu 0 (0), All Menus (1), Read-only Menu 0 (2), Read-only (3), Status Only (4), No Access (5)			Menu 0 (0)			RW	Txt	ND		PT	
00.0050	Software Version	{11.029}	0 to 99999999						RO	Num	ND	NC	PT	
00.0051	Action On Trip Detection	{10.037}	0 to 31			0			RW	Bin				US
00.0052	Reset Serial Communications*	{11.020}	Off (0) or On (1)			Off (0)			RW	Bit	ND	NC		

\* Only applicable to Unidrive HS71.

\*\* Only applicable to Unidrive HS70 / HS72.

\*\*\* Only applicable to Unidrive HS72.

\*\*\*\* Only applicable to Unidrive HS70 / HS71.

RW	Read / Write	RO	Read only	Num	Number parameter	Bit	Bit parameter	Txt	Text string	Bin	Binary parameter	FI	Filtered
ND	No default value	NC	Not copied	PT	Protected parameter	RA	Rating dependent	US	User save	PS	Power-down save	DE	Destination
IP	IP address	Mac	Mac address	Date	Date parameter	Time	Time parameter						



Figure 5-1 Menu 0 logic diagram (Unidrive HS70 / HS71)

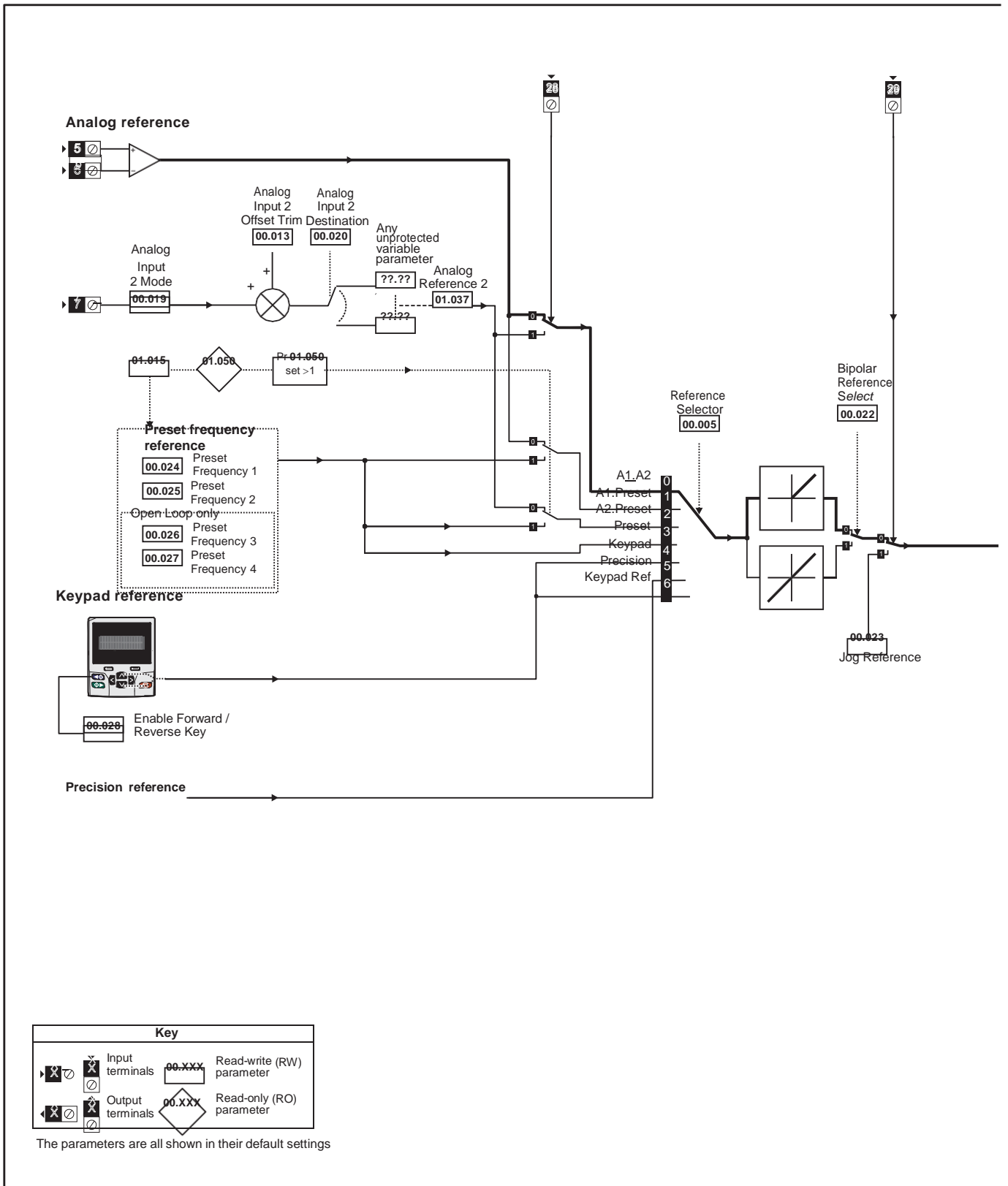

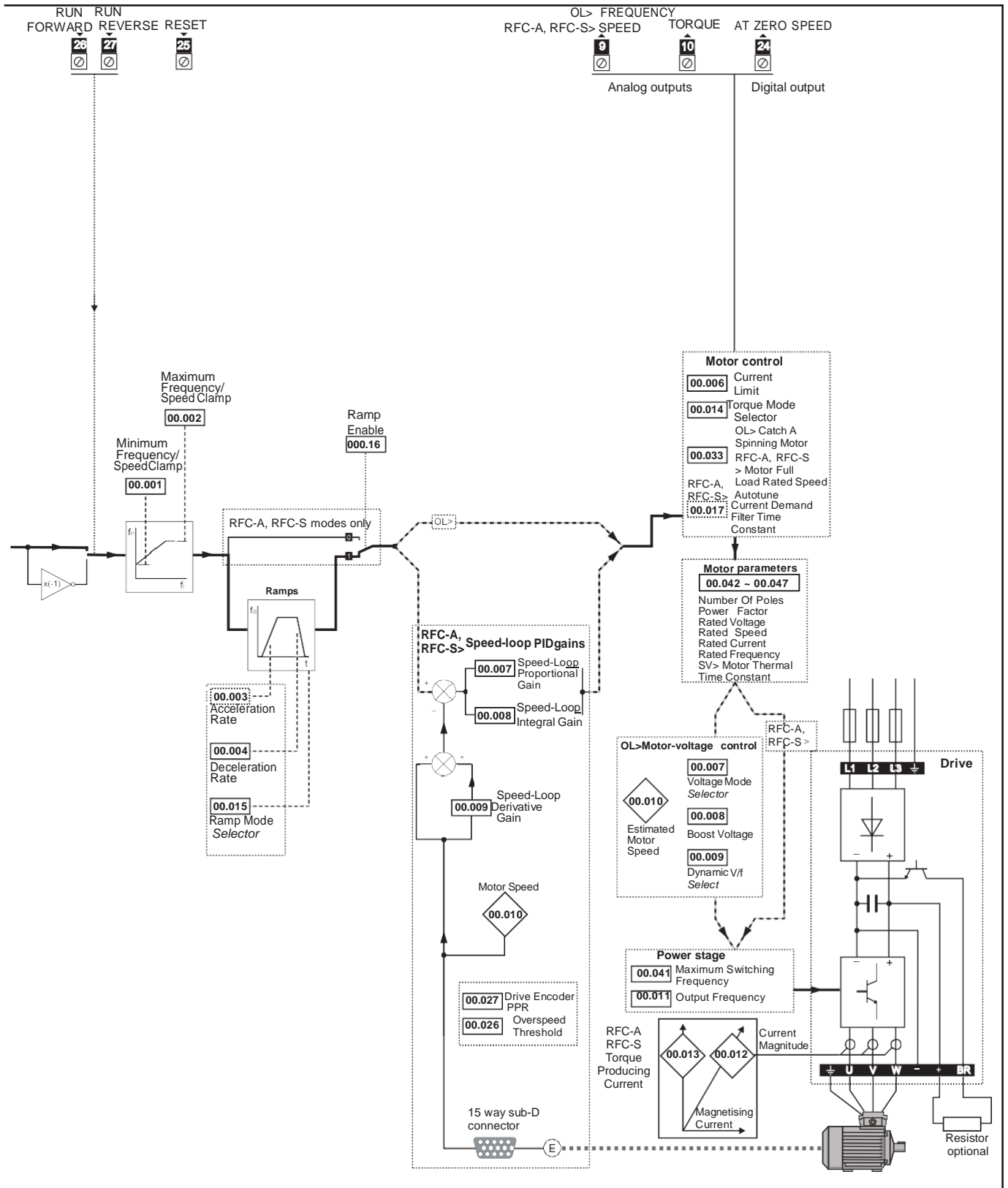
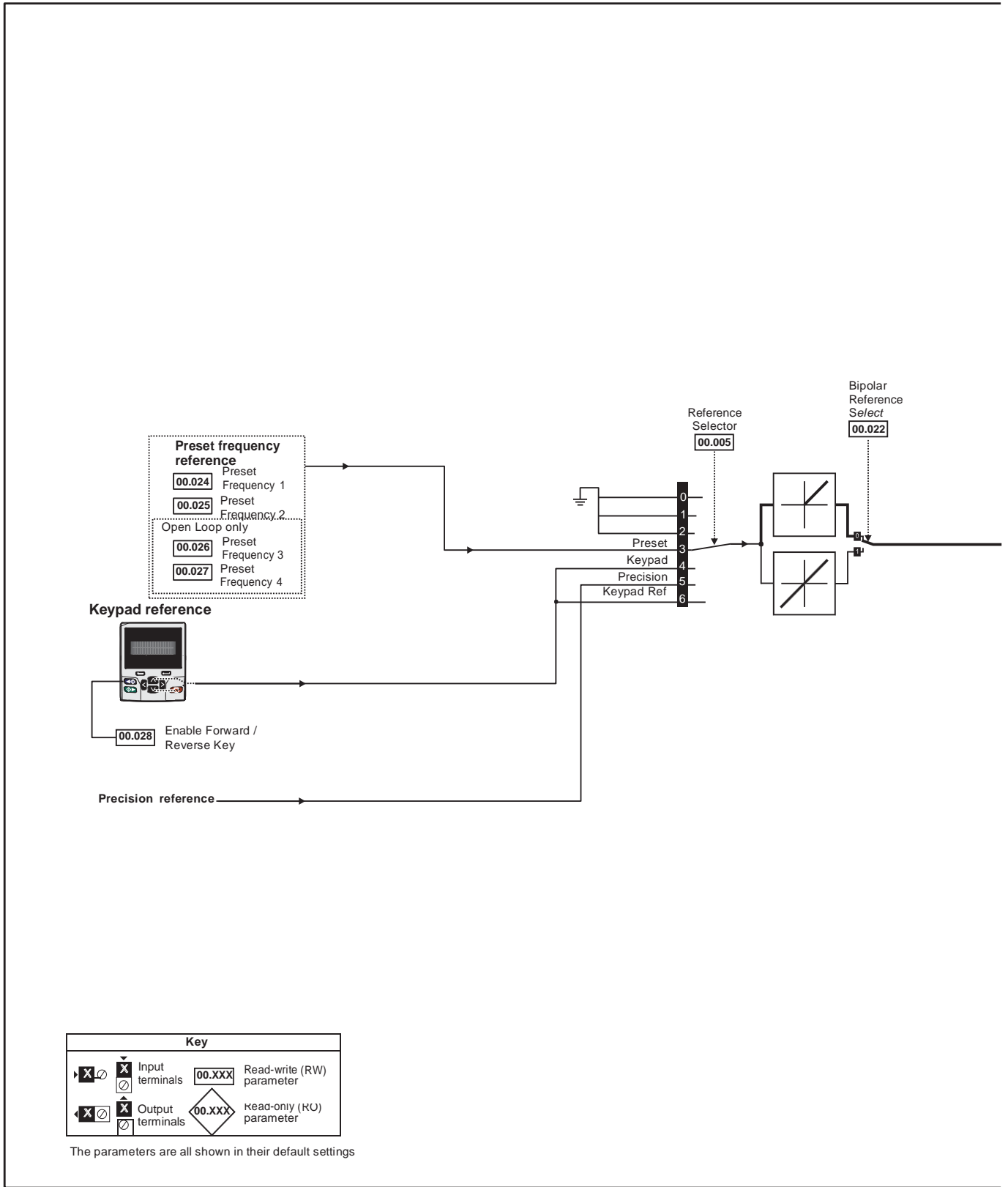
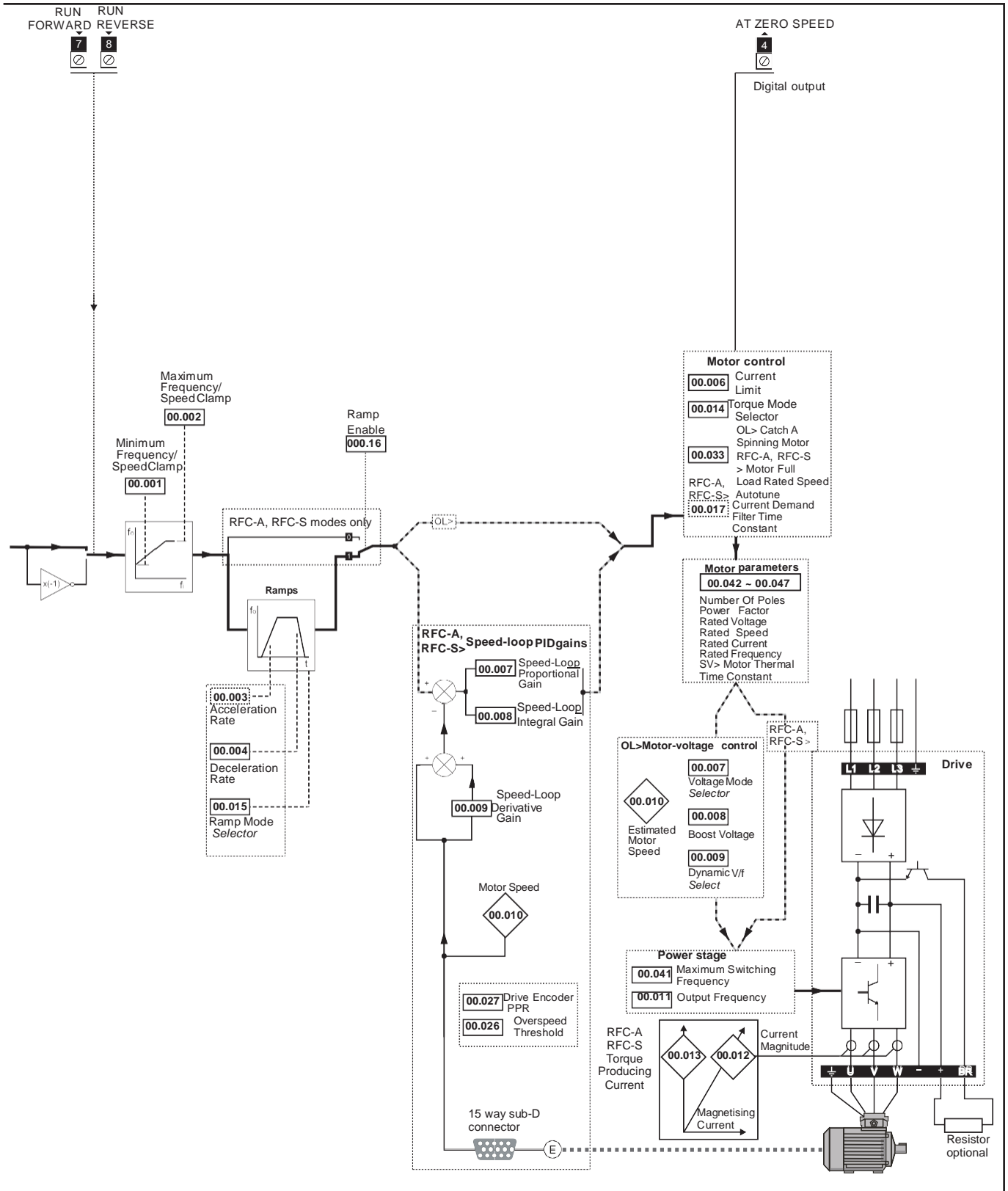

Figure 5-2 Menu 0 logic diagram (Unidrive HS72)





## 5.2 Parameter descriptions

### 5.2.1 Pr mm.000

Pr **mm.000** is available in all menus, commonly used functions are provided as text strings in Pr **mm.000** shown in Table 5.2. The functions in Table 5-1 can also be selected by entering the appropriate numeric values (as shown in Table 5.3) in Pr **mm.000**. For example, enter 7001 in Pr **mm.000** to erase the file in NV media card location 001.

**Table 5-1 Commonly used functions in xx.000**

Value	Equivalent value	String	Action
0	0	[No Action]	
1000	1	[Save parameters]	Save parameters when under voltage is not active and low voltage threshold is not active
6001	2	[Load file 1]	Load the drive parameters or user program file from NV media card file 001
4001	3	[Save to file 1]	Transfer the drive parameters to parameter file 001
6002	4	[Load file 2]	Load the drive parameters or user program file from NV media card file 002
4002	5	[Save to file 2]	Transfer the drive parameters to parameter file 002
6003	6	[Load file 3]	Load the drive parameters or user program file from NV media card file 003
4003	7	[Save to file 3]	Transfer the drive parameters to parameter file 003
12000	8	[Show non-default]	Displays parameters that are different from defaults
12001	9	[Destinations]	Displays parameters that are set
1233	10	[Reset 50Hz Defs]	Load parameters with standard (50 Hz) defaults
1244	11	[Reset 60Hz Defs]	Load parameters with US (60 Hz) defaults
1070	12	[Reset modules]	Reset all option modules
11001	13	[Read Enc. NP P1]	Transfer electronic nameplate motor parameters to the drive from the P1 encoder
11051	14	[Read Enc. NP P2]	Transfer electronic nameplate motor parameters to the drive from the P2 encoder

**Table 5-2 Functions in Pr mm.000**

Value	Action
1000	Save parameters when <i>Under Voltage Active</i> (Pr 10.016) is not active and <i>Low Under Voltage Threshold Select</i> mode (Pr 06.067 = Off) is not active.
1001	Save parameter under all conditions
1070	Reset all option modules
1233	Load standard (50 Hz) defaults
1234	Load standard (50 Hz) defaults to all menus except option module menus (i.e 15 to 20 and 24 to 28)
1244	Load US (60 Hz) defaults
1245	Load US (60 Hz) defaults to all menus except option module menus (i.e 15 to 20 and 24 to 28)
1253	Change drive mode and load standard (50 Hz) defaults
1254	Change drive mode and load US (60 Hz) defaults
1255	Change drive mode and load standard (50 Hz) defaults except for menus 15 to 20 and 24 to 28
1256	Change drive mode and load US (60 Hz) defaults except for menus 15 to 20 and 24 to 28
1299	Reset {Stored HF} trip.
2001*	Create a boot file on a non-volatile media card based on the present drive parameters including all Menu 20 parameters
4yyy*	NV media card: Transfer the drive parameters to parameter file xxx
5yyy*	NV media card: Transfer the onboard user program to onboard user program file xxx
6yyy*	NV media card: Load the drive parameters from parameter file xxx or the onboard user program from onboard user program file xxx
7yyy*	NV media card: Erase file xxx
8yyy*	NV Media card: Compare the data in the drive with file xxx
9555*	NV media card: Clear the warning suppression flag
9666*	NV media card: Set the warning suppression flag
9777*	NV media card: Clear the read-only flag
9888*	NV media card: Set the read-only flag
9999*	NV media card: Erase and format the NV media card
110S0	Transfer electronic nameplate motor object parameters from the drive to an encoder connected to the drive or an option module.
110S1	Transfer electronic nameplate motor objects parameters from an encoder connected to the drive or option module to the drive parameters.
110S2	As 110S0, but for performance object 1
110S3	As 110S1, but for performance object 1
110S4	As 110S0, but for performance object 2
110S5	As 110S1, but for performance object 2
110S6	Transfer electronic nameplate motor object parameters from the drive to an encoder connected to the drive or an option module in the Unidrive SP format.
12000**	Only display parameters that are different from their default value. This action does not require a drive reset.
12001**	Only display parameters that are used to set-up destinations (i.e. DE format bit is 1). This action does not require a drive reset.
15xxx*	Transfer the user program in an option module installed in slot 1 to a non-volatile media card file xxx
16xxx*	Transfer the user program in an option module installed in slot 2 to a non-volatile media card file xxx
17xxx*	Transfer the user program in an option module installed in slot 3 to a non-volatile media card file xxx
18xxx*	Transfer the user program from file xxx in a non-volatile media card to an option module installed in slot 1.
19xxx*	Transfer the user program from file xxx in a non-volatile media card to an option module installed in slot 2.
20xxx*	Transfer the user program from file xxx in a non-volatile media card to an option module installed in slot 3.
21xxx*	Transfer the user program in an option module installed in slot 4 to a non-volatile media card file xxx.
22xxx*	Transfer the user program from file xxx in a non-volatile media card to an option module installed in slot 4.

\* See Chapter 8 *NV Media Card Operation* on page 89 for more information on these functions.

\*\* These functions do not require a drive reset to become active. All other functions require a drive reset to initiate the function. Equivalent values and strings are also provided in the table above.

## 5.3 Full descriptions

Table 5-3 Key to parameter table coding

Coding	Attribute
<b>RW</b>	Read/Write: can be written by the user
<b>RO</b>	Read only: can only be read by the user
<b>Bit</b>	1 bit parameter. 'On' or 'Off' on the display
<b>Num</b>	Number: can be uni-polar or bi-polar
<b>Txt</b>	Text: the parameter uses text strings instead of numbers.
<b>Bin</b>	Binary parameter
<b>IP</b>	IP Address parameter
<b>Mac</b>	Mac Address parameter
<b>Date</b>	Date parameter
<b>Time</b>	Time parameter
<b>Chr</b>	Character parameter
<b>FI</b>	Filtered: some parameters which can have rapidly changing values are filtered when displayed on the drive keypad for easy viewing.
<b>DE</b>	Destination: This parameter selects the destination of an input or logic function.
<b>RA</b>	Rating dependent: this parameter is likely to have different values and ranges with drives of different voltage and current ratings. Parameters with this attribute will be transferred to the destination drive by non-volatile storage media when the rating of the destination drive is different from the source drive and the file is a parameter file. However, the values will be transferred if only the current rating is different and the file is a difference from default type file.
<b>ND</b>	No default: The parameter is not modified when defaults are loaded
<b>NC</b>	Not copied: not transferred to or from non-volatile media during copying.
<b>PT</b>	Protected: cannot be used as a destination.
<b>US</b>	User save: parameter saved in drive EEPROM when the user initiates a parameter save.
<b>PS</b>	Power-down save: parameter automatically saved in drive EEPROM when the under volts (UV) trip occurs.

### 5.3.1 Parameter x.00

00.000 {mm.000}		Parameter zero						
RW	Num				ND	NC	PT	
↕	0 to 65,535							

### 5.3.2 Speed limits

00.001 {01.007}		Minimum Reference Clamp						
RW	Num						US	
OL	↕	±VM_NEGATIVE_REF_CLAMP1 Hz / rpm	⇒					0.0 Hz
RFC-A								0.0 rpm
RFC-S								

(When the drive is jogging, [00.001] has no effect.)

#### Open-loop

Set Pr **00.001** at the required minimum output frequency of the drive for both directions of rotation. The drive speed reference is scaled between Pr **00.001** and Pr **00.002**. [00.001] is a nominal value; slip compensation may cause the actual frequency to be higher.

#### RFC-A / RFC-S

Set Pr **00.001** at the required minimum motor speed for both directions of rotation. The drive speed reference is scaled between Pr **00.001** and Pr **00.002**.

00.002 {01.006}		Maximum Reference Clamp						
RW	Num						US	
OL	↕	±VM_POSITIVE_REF_CLAMP1 Hz / rpm	⇒					50Hz default: 50.0 Hz 60Hz default: 60.0 Hz
RFC-A								50Hz default: 1500.0 Hz 60Hz default: 1800.0 Hz
RFC-S								3000.0 rpm

(The drive has additional over-speed protection).

#### Open-loop

Set Pr **00.002** at the required maximum output frequency for both directions of rotation. The drive speed reference is scaled between Pr **00.001** and Pr **00.002**. [00.002] is a nominal value; slip compensation may cause the actual frequency to be higher.

#### RFC-A / RFC-S

Set Pr **00.002** at the required maximum motor speed for both directions of rotation. The drive speed reference is scaled between Pr **00.001** and Pr **00.002**.

For operating at high speeds see section 7.6 *High speed operation* on page 87.

### 5.3.3 Ramps, speed reference selection, current limit

00.003 {02.011}		Acceleration Rate 1						
RW	Num						US	
OL	↕	±VM_ACCEL_RATE	⇒					5.0 s/100 Hz
RFC-A								2.000 s/1000 rpm
RFC-S								0.200 s/1000 rpm

Set Pr **00.003** at the required rate of acceleration.

Note that larger values produce lower acceleration. The rate applies in both directions of rotation.

00.004 {02.021}		Deceleration Rate 1						
RW	Num						US	
OL	↕	±VM_ACCEL_RATE	⇒					10.0 s/100 Hz
RFC-A								2.000 s/1000 rpm
RFC-S								0.200 s/1000 rpm

Set Pr **00.004** at the required rate of deceleration.

Note that larger values produce lower deceleration. The rate applies in both directions of rotation.

00.005 {01.014}		Reference Selector						
RW	Txt						US	
OL	↕	A1 A2 (0)*, A1 Preset (1)*, A2 Preset (2)*, Preset (3), Keypad (4), Precision (5), Keypad Ref (6)	⇒					HS70 / HS71: A1 A2 (0) HS72: Preset (3)
RFC-A								
RFC-S								

\* Available on *Unidrive HS70 / HS71* only.

Use Pr **00.005** to select the required frequency/speed reference as follows:

Setting	Description
A1 A2*	0 Analog input 1 OR analog input 2 selectable by digital input, terminal 28
A1 Preset*	1 Analog input 1 OR preset frequency/speed
A2 Preset*	2 Analog input 2 OR preset frequency/speed
Preset (3)	3 Pre-set frequency/speed
Keypad (4)	4 Keypad mode
Precision (5)	5 Precision reference
Keypad Ref (6)	6 Keypad Reference

\* Available on *Unidrive HS70 / HS71* only.

00.006 {04.007} Symmetrical Current Limit	
RW	Num
OL	165 %
RFC-A	±VM_MOTOR1_CURRENT_LIMIT %
RFC-S	

Pr **00.006** limits the maximum output current of the drive (and hence maximum motor torque) to protect the drive and motor from overload. Set Pr **00.006** at the required maximum torque as a percentage of the rated torque of the motor, as follows:

$$[00.006] = \frac{T_R}{T_{RATED}} \times 100 (\%)$$

Where:

$T_R$  Required maximum torque  
 $T_{RATED}$  Motor rated torque

Alternatively, set Pr **00.006** at the required maximum active (torque-producing) current as a percentage of the rated active current of the motor, as follows:

$$[00.006] = \frac{I_R}{I_{RATED}} \times 100 (\%)$$

Where:

$I_R$  Required maximum active current  
 $I_{RATED}$  Motor rated active current

### 5.3.4 Voltage boost, (open-loop), Speed-loop PID gains (RFC-A / RFC-S)

00.007 {05.014} Open-loop Control Mode (OL)	
00.007 {03.010} Speed Controller Proportional Gain Kp1 (RFC)	
RW	Txt / Num
OL	Ur S (0), Ur (1), Fixed (2), Ur Auto (3), Ur I (4), Square (5), Current 1P (6)
RFC-A	0.0300 s/rad
RFC-S	0.0100 s/rad

#### Open-loop

There are seven voltage modes available, which fall into three categories, vector control, fixed boost and single phase current output. For further details, refer to section *Pr 00.007 {05.014} Open Loop Control Mode* on page 78.

#### RFC-A/ RFC-S

Pr **00.007 (03.010)** operates in the feed-forward path of the speed-control loop in the drive. See Figure 10-4 on page 116 for a schematic of the speed controller. For information on setting up the speed controller gains, refer to Chapter 7 *Optimization* on page 77.

00.008 {05.015} Low Frequency Voltage Boost (OL)	
00.008 {03.011} Speed Controller Integral Gain Ki1 (RFC)	
RW	Num
OL	0.0 to 25.0 %
RFC-A	0.10 s <sup>2</sup> /rad
RFC-S	1.00 s <sup>2</sup> /rad

#### Open-loop

When *Open-loop Control Mode* (00.007) is set at **Fd** or **SrE**, set Pr **00.008 (05.015)** at the required value for the motor to run reliably at low speeds.

Excessive values of Pr **00.008** can cause the motor to be overheated.

#### RFC-A/ RFC-S

Pr **00.008 (03.011)** operates in the feed-forward path of the speed-control loop in the drive. See Figure 10-4 on page 116 for a schematic of the speed controller. For information on setting up the speed controller gains, refer to Chapter 7 *Optimization* on page 77.

00.009 {05.013} Dynamic V to F Select (OL)	
00.009 {03.012} Speed Controller Differential Feedback Gain Kd 1 (RFC)	
RW	Bit
OL	Off (0) or On (1)
RFC-A	0.00000 to 0.65535 1/rad
RFC-S	0.00000 1/rad

#### Open-loop

Set Pr **00.009 (05.013)** at 0 when the V/f characteristic applied to the motor is to be fixed. It is then based on the rated voltage and frequency of the motor.

Set Pr **00.009** at 1 when reduced power dissipation is required in the motor when it is lightly loaded. The V/f characteristic is then variable resulting in the motor voltage being proportionally reduced for lower motor currents. Figure 5-3 shows the change in V/f slope when the motor current is reduced.

#### RFC-A / RFC-S

Pr **00.009 (03.012)** operates in the feedback path of the speed-control loop in the drive. See Figure 10-4 *Menu 3 RFC-A, RFC-S logic diagram* on page 116 for a schematic of the speed controller. For information on setting up the speed controller gains, refer to Chapter 7 *Optimization* on page 77.

**Figure 5-3 Fixed and variable V/f characteristics**

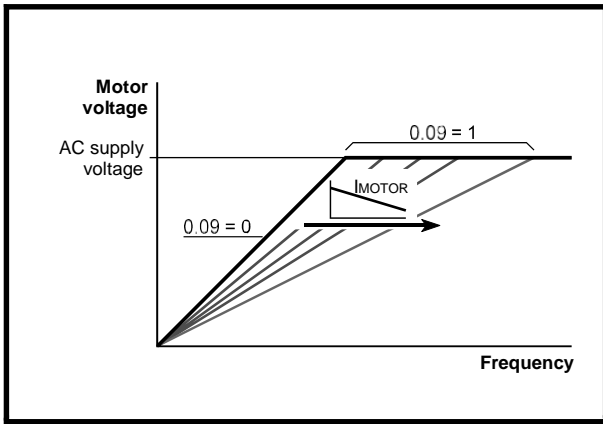

Pr **00.012** displays the rms value of the output current of the drive in each of the three phases. The phase currents consist of an active component and a reactive component, which can form a resultant current vector as shown in the following diagram.

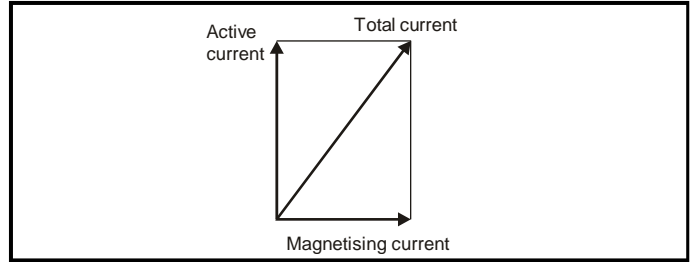

The active current is the torque producing current and the reactive current is the magnetizing or flux-producing current.

### 5.3.5 Monitoring

00.010 {05.004} Motor Rpm										
RW	Bit								US	
OL	↕	±180000 rpm				⇒	0 rpm			

#### Open-loop

Pr **00.010 (05.004)** indicates the value of motor speed that is estimated from the following:

- 02.001 Post Ramp Reference
- 00.042 Number Of Motor Poles

00.010 {03.002} Speed Feedback										
RO	Num	FI			ND	NC	PT			
RFC-A	↕	±VM_SPEED rpm				⇒				
RFC-S										

#### RFC-A / RFC-S

Pr **00.010 (03.002)** indicates the value of motor speed that is obtained from the speed feedback.

00.011 {05.001} Output Frequency (OL)										
00.011 {03.029} P1 Position (RFC)										
RO	Num	FI			ND	NC	PT			
OL	↕	±VM_SPEED_FREQ_REF Hz				⇒				
RFC-A										
RFC-S	↕	0 to 65535				⇒				

#### Open-loop and RFC-A

Pr **00.011** displays the frequency at the drive output.

#### RFC-S

Pr **00.011** displays the position of the encoder in mechanical values of 0 to 65,535. There are 65,536 units to one mechanical revolution.

00.012 {04.001} Current Magnitude										
RO	Bit	FI			ND	NC	PT			
OL	↕	±VM_DRIVE_CURRENT_UNIPOLAR A				⇒				
RFC-A										
RFC-S										

00.013 {04.002} Torque Producing Current										
RO	Bit	FI			ND	NC	PT			
OL	↕	±VM_DRIVE_CURRENT A				⇒				
RFC-A										
RFC-S										

When the motor is being driven below its rated speed, the torque is proportional to **[00.013]**.

### 5.3.6 Jog reference, Ramp mode selector, Stop and torque mode selectors

Pr **00.014** is used to select the required control mode of the drive as follows:

00.014 {04.011} Torque Mode Selector										
RW	Num								US	
OL	↕	0 or 1				⇒	0			
RFC-A	↕	0 to 5				⇒	0			
RFC-S										

Setting	Open-Loop	RFC-A/S
0	Frequency control	Speed control
1	Torque control	Torque control
2		Torque control with speed override
3		Coiler/uncoiler mode
4		Speed control with torque feed-forward
5		Bi-directional torque control with speed override

00.015 {02.004} Ramp Mode Select										
RW	Txt								US	
OL	↕	Fast (0), Standard (1), Std boost (2)				⇒	Standard (1)			
RFC-A	↕	Fast (0), Standard (1)				⇒	Standard (1)			
RFC-S										

Pr **00.015** sets the ramp mode of the drive as shown below:

## 0: Fast ramp

Fast ramp is used where the deceleration follows the programmed deceleration rate subject to current limits. This mode must be used if a braking resistor is connected to the drive.

## 1: Standard ramp

Standard ramp is used. During deceleration, if the voltage rises to the standard ramp level (Pr **02.008**) it causes a controller to operate, the output of which changes the demanded load current in the motor. As the controller regulates the link voltage, the motor deceleration increases as the speed approaches zero speed. When the motor deceleration rate reaches the programmed deceleration rate the controller ceases to operate and the drive continues to decelerate at the programmed rate. If the standard ramp voltage (Pr **02.008**) is set lower than the nominal DC bus level the drive will not decelerate the motor, but it will coast to rest. The output of the ramp controller (when active) is a current demand that is fed to the frequency changing current controller (Open-loop modes) or the torque producing current controller (RFC-A or RFC-S modes). The gain of these controllers can be modified with Pr **04.013** and Pr **04.014**.

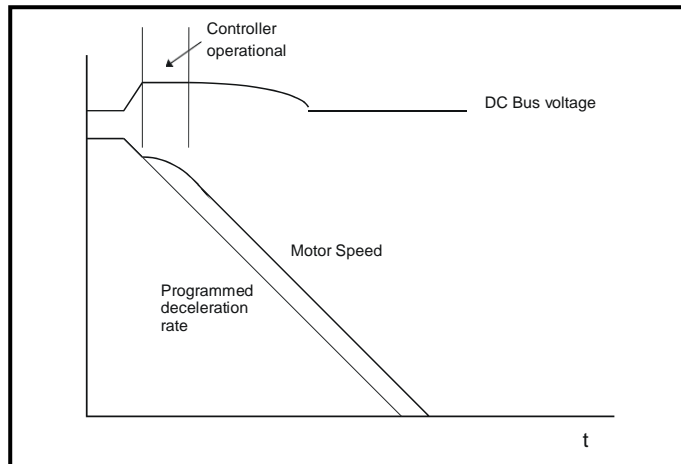

## 2: Standard ramp with motor voltage boost

This mode is the same as normal standard ramp mode except that the motor voltage is boosted by 20 %. This increases the losses in the motor, dissipating some of the mechanical energy as heat giving faster deceleration.

00.016 {02.002}		Ramp Enable											
RW	Bit											US	
OL	⇕												
RFC-A	⇕	Off (0) or On (1)										⇒	On (1)
RFC-S													

Setting Pr **00.016** to 0 allows the user to disable the ramps. This is generally used when the drive is required to closely follow a speed reference which already contains acceleration and deceleration ramps.

00.017 {08.026}		Digital Input 6 Destination*											
RW	Num	DE					PT	US					
OL	⇕	00.000 to 59.999						⇒	06.031				

\* Not applicable to *Unidrive HS72*.

### Open-loop

Pr **00.017** sets the destination of digital input T29.

00.017 {04.012}		Current Reference Filter Time Constant											
RW	Num											US	
RFC-A	⇕	0.0 to 25.0 ms						⇒	0.0 ms				
RFC-S													

### RFC-A / RFC-S

A first order filter, with a time constant defined by Pr **00.017**, is provided on the current demand to reduce acoustic noise and vibration produced as a result of position feedback quantisation noise. The filter introduces a lag in the speed loop, and so the speed loop gains may need to be reduced to maintain stability as the filter time constant is increased.

00.019 {07.011}		Analog Input 2 Mode*										
RW	Num											US
OL		4-20 mA Low (-4), 20-4 mA Low (-3), 4-20 mA Hold (-2), 20-4 mA Hold (-1), 0-20 mA (0), 20-0 mA (1), 4-20 mA Trip (2), 20-4 mA Trip (3), 4-20 mA (4), 20-4 mA (5), Volt (6)										
RFC-A	⇕											
RFC-S												

\* Not applicable to *Unidrive HS72*.

In modes 2 and 3 a current loop loss trip is generated if the current falls below 3 mA.

In modes -4, -3, 2 and 3 the analog input level goes to 0.0 % if the input current falls below 3 mA.

In modes -2 and -1 the analog input remains at the value it had in the previous sample before the current fell below 3mA.

Pr Value	Pr string	Comments
-4	4-20 mA Low	4-20 mA low value on current loss (1)
-3	20-4 mA Low	20-4 mA low value on current loss (1)
-2	4-20 mA Hold	4-20 mA hold at level before loss on current loss
-1	20-4 mA Hold	20-4 mA hold at level before loss on current loss
0	0-20 mA	
1	20-0 mA	
2	4-20 mA Trip	4-20 mA trip on current loss
3	20-4 mA Trip	20-4 mA trip on current loss
4	4-20 mA	
5	20-4 mA	
6	Volt	

00.020 {07.014}		Analog Input 2 Destination*											
RW	Num	DE					PT	US					
OL	⇕	00.000 to 59.999						⇒	01.037				
RFC-A													
RFC-S													

\* Not applicable to *Unidrive HS72*.

Pr **00.020** sets the destination of analog input 2.



00.021 {07.015} Analog Input 3 Mode*	
RW	Txt
OL	Volt (6), Therm Short Cct (7), Thermistor (8), Therm No Trip (9)
RFC-A	↕
RFC-S	⇒ Volt (6)

\* Not applicable to Unidrive HS72.

Pr value	Pr string	Comments
6	Volt	
7	Therm Short Cct	Temperature measurement input with short circuit detection
8	Thermistor	Temperature measurement without short circuit detection
9	Therm No Trip	Temperature measurement input with no trips

00.022 {01.010} Bipolar Reference Enable	
RW	Bit
OL	
RFC-A	↕ OFF (0) or On (1)
RFC-S	⇒ OFF (0)

Pr 00.022 determines whether the reference is uni-polar or bi-polar as follows:

Pr 00.022	Function
0	Unipolar speed/frequency reference 
1	Bipolar speed/frequency reference 

00.023 {01.005} Jog Reference	
RW	Num
OL	0.0 to 4000.0 Hz
RFC-A	↕ Enter the required value of jog frequency/speed.
RFC-S	⇒ 0.0
	Frequency/speed limits affect the drive when jogging as follows:
	0.0 to 4000.0 rpm
	0.0

Frequency-limit parameter	Limit applies
Pr 00.001 Minimum reference clamp	No
Pr 00.002 Maximum reference clamp	Yes

00.024 {01.021} Preset Reference 1	
RW	Num
OL	
RFC-A	↕ ±VM_SPEED_FREQ_REF rpm
RFC-S	⇒ 0.0

00.025 {01.022} Preset Reference 2	
RW	Num
OL	
RFC-A	↕ ±VM_SPEED_FREQ_REF rpm
RFC-S	⇒ 0.0

00.026 {01.023} Preset Reference 3 (OL)	
00.026 {03.008} Overspeed Threshold (RFC)	
RW	Num
OL	↕ ±VM_SPEED_FREQ_REF Hz
RFC-A	↕ 0 to 50000 rpm
RFC-S	⇒ 0.0

#### Open-loop

If the preset reference has been selected (see Pr 00.005), the speed at which the motor runs is determined by these parameters.

#### RFC-A / RFC-S

If the speed feedback (Pr 03.002) exceeds this level in either direction, an overspeed trip is produced. If this parameter is set to zero, the overspeed threshold is automatically set to 120 % x SPEED\_FREQ\_MAX.

00.027 {01.024} Preset Reference 4 (OL)	
00.027 {03.034} P1 Rotary Lines Per Revolution (RFC)	
RW	Num
OL	↕ ±VM_SPEED_FREQ_REF Hz
RFC-A	↕ 1 to 100000
RFC-S	⇒ 1024
	4096

#### Open-loop

Refer to Pr 00.024 to Pr 00.026.

#### RFC-A / RFC-S

Enter in Pr 00.027 the number of lines per revolution of the drive encoder.

00.028 {06.013} Enable Auxiliary Key	
RW	Num
OL	
RFC-A	↕ 0 to 2
RFC-S	⇒ 0

When a keypad is installed, this parameter enables the forward/reverse key.

00.029 {11.036}		NV Media Card Data Previously Loaded										
RO	Num						NC	PT	US			
OL												
RFC-A	⇕	0 to 999					⇒					
RFC-S												

This parameter shows the number of the data block last transferred from a SMARTCARD to the drive.

00.030 {11.42}		Parameter Cloning										
RO	Txt						NC		US*			
OL												
RFC-A	⇕	None (0), Read (1), Program (2), Auto (3), Boot (4)					⇒	None (0)				
RFC-S												

\* Only a value of 3 or 4 in this parameter is saved.

**NOTE**

If Pr **00.030** is equal to 1 or 2 this value is not transferred to the EEPROM or the drive. If Pr **00.030** is set to a 3 or 4 the value is transferred.

Pr String	Pr value	Comment
None	0	Inactive
Read	1	Read parameter set from the NV Media Card
Program	2	Programming a parameter set to the NV Media Card
Auto	3	Auto save
Boot	4	Boot mode

For further information, please refer to Chapter 8 *NV Media Card Operation* on page 89.

00.031 {11.033}		Drive Rated Voltage										
RO	Txt					ND	NC	PT				
OL												
RFC-A	⇕	200 V (0), 400 V (1), 575 V (2), 690 V (3)					⇒					
RFC-S												

Pr **00.031** indicates the voltage rating of the drive.

00.032 {11.032}		Maximum Heavy Duty Rating										
RO	Num					ND	NC	PT				
OL												
RFC-A	⇕	0.000 to 99999.999 A					⇒					
RFC-S												

Pr **00.032** indicates the maximum continuous Heavy Duty current rating.

00.033 {06.009}		Catch A Spinning Motor (OL)										
00.033 {05.016}		Motor Parameter Adaptive Control (RFC-A)										
RW	Num											US
OL	⇕	Disable (0), Enable (1), Fwd Only (2), Rev Only (3)					⇒	Disable (0)				
RFC-A	⇕	0 to 2					⇒	0				

**Open-loop**

When the drive is enabled with Pr **00.033** = 0, the output frequency starts at zero and ramps to the required reference. When the drive is enabled when Pr **00.033** has a non-zero value, the drive performs a start-up test to determine the motor speed and then sets the initial output frequency to the synchronous frequency of the motor. Restrictions may be placed on the frequencies detected by the drive as follows:

Pr 00.033	Pr string	Function
0	Disable	Disabled
1	Enable	Detect all frequencies
2	Fwd only	Detect positive frequencies only
3	Rev only	Detect negative frequencies only

**RFC-A**

The motor rated full load rpm parameter (Pr **00.045**) in conjunction with the motor rated frequency parameter (Pr **00.046**) defines the full load slip of the motor. The slip is used in the motor model for closed-loop vector control. The full load slip of the motor varies with rotor resistance which can vary significantly with motor temperature. When Pr **00.033** is set to 1 or 2, the drive can automatically sense if the value of slip defined by Pr **00.045** and Pr **00.046** has been set incorrectly or has varied with motor temperature. If the value is incorrect parameter Pr **00.045** is automatically adjusted. The adjusted value in Pr **00.045** is not saved at power-down. If the new value is required at the next power-up it must be saved by the user.

Automatic optimization is only enabled when the speed is above 12.5 % of rated speed, and when the load on the motor load rises above 62.5 % rated load. Optimization is disabled again if the load falls below 50 % of rated load.

For best optimization results the correct values of stator resistance (Pr **05.017**), transient inductance (Pr **05.024**), stator inductance (Pr **05.025**) and saturation breakpoints (Pr **05.029**, Pr **05.030**) should be stored in the relevant parameters. These values can be obtained by the drive during an autotune (see Pr **00.040** for further details).

Rated rpm auto-tune is not available if the drive is not using external position/speed feedback.

The gain of the optimizer, and hence the speed with which it converges, can be set at a normal low level when Pr **00.033** is set to 1. If this parameter is set to 2 the gain is increased by a factor of 16 to give faster convergence.

00.034 {11.030}		User security code										
RW	Num					ND	NC	PT	US			
OL												
RFC-A	⇕	0 to 2 <sup>31</sup> -1					⇒	0				
RFC-S												

If any number other than 0 is programmed into this parameter, user security is applied so that no parameters except Pr **00.049** can be adjusted with the keypad. When this parameter is read via a keypad it appears as zero. For further details refer to section 4.9.3 *User Security Code* on page 38.

00.035 {11.024} Serial Mode*	
RW	Txt
OL	8 2 NP (0), 8 1 NP (1), 8 1 EP (2), 8 1 OP (3),
RFC-A	8 2 NP M (4), 8 1 NP M (5), 8 1 EP M (6),
RFC-S	8 1 OP M (7), 7 2 NP (8), 7 1 NP (9), 7 1 EP (10), 7 1 OP (11), 7 2 NP M (12), 7 1 NP M (13), 7 1 EP M (14), 7 1 OP M (15)
	⇒ 8 2 NP (0)

\* Only applicable to *Unidrive HS71*.

This parameter defines the communications protocol used by the EIA485 comms port on the drive. This parameter can be changed via the drive keypad, via a Solutions Module or via the comms interface itself. If it is changed via the comms interface, the response to the command uses the original protocol. The master should wait at least 20 ms before send a new message using the new protocol. (Note: ANSI uses 7 data bits, 1 stop bit and even parity; Modbus RTU uses 8 data bits, 2 stops bits and no parity).

Pr Value	Pr String
0	8 2 NP
1	8 1 NP
2	8 1 EP
3	8 1 OP
4	8 2 NP M
5	8 1 NP M
6	8 1 EP M
7	8 1 OP M
8	7 2 NP
9	7 1 NP
10	7 1 EP
11	7 1 OP
12	7 2 NP M
13	7 1 NP M
14	7 1 EP M
15	7 1 OP M

The core drive always uses the Modbus rtu protocol and is always a slave. *Serial Mode* (11.024) defines the data format used by the serial comms interface. The bits in the value of *Serial Mode* (11.024) define the data format as follows. Bit 3 is always 0 in the core product as 8 data bits are required for Modbus rtu. The parameter value can be extended in derivative products which provide alternative communications protocols if required.

Bits	3	2	1 and 0
Format	Number of data bits 0 = 8 bits 1 = 7 bits	Register mode 0 = Standard 1 = Modified	Stop bits and Parity 0 = 2 stop bits, no parity 1 = 1 stop bit, no parity 2 = 1 stop bit, even parity 3 = 1 stop bit, odd parity

Bit 2 selects either standard or modified register mode. The menu and parameter numbers are derived for each mode as given in the following table. Standard mode is compatible with Unidrive SP. Modified mode is provided to allow register numbers up to 255 to be addressed. If any menus with numbers above 63 should contain more than 99 parameters, then these parameters cannot be accessed via Modbus rtu.

Register mode	Register address
Standard	(mm x 100) + ppp - 1 where mm ≤ 162 and ppp ≤ 99
Modified	(mm x 256) + ppp - 1 where mm ≤ 63 and ppp ≤ 255

Changing the parameters does not immediately change the serial communications settings. See *Reset Serial Communications* (11.020) for more details.

00.036 {11.025} Serial Baud Rate*	
RW	Txt
OL	300 (0), 600 (1), 1200 (2), 2400 (3), 4800 (4),
RFC-A	9600 (5), 19200 (6), 38400 (7), 57600 (8),
RFC-S	76800 (9), 115200 (10)
	⇒ 19200 (6)

\* Only applicable to *Unidrive HS71*.

This parameter can be changed via the drive keypad, via a Solutions Module or via the comms interface itself. If it is changed via the comms interface, the response to the command uses the original baud rate. The master should wait at least 20 ms before send a new message using the new baud rate.

00.037 {11.023} Serial Address*	
RW	Num
OL	
RFC-A	1 to 247
RFC-S	
	⇒ 1

\* Only applicable to *Unidrive HS71*.

Used to define the unique address for the drive for the serial interface. The drive is always a slave address 0 is used to globally address all slaves, and so this address should not be set in this parameter

00.037 {24.010} Active IP Address*	
RO	IP
OL	
RFC-A	000.000.000.000 to 255.255.255.255
RFC-S	
	⇒

\* Only applicable to *Unidrive HS70* and *Unidrive HS72*.

00.038 {04.013} Current Controller Kp Gain	
RW	Num
OL	
RFC-A	0 to 30000
RFC-S	
	⇒ 20
	⇒ 150

00.039 {04.014}		Current Controller Ki Gain											
RW	Num											US	
OL	↕	0 to 30000					⇒	40					
RFC-A	↕						⇒	2000					
RFC-S	↕						⇒						

These parameters control the proportional and integral gains of the current controller used in the open loop drive. The current controller either provides current limits or closed loop torque control by modifying the drive output frequency. The control loop is also used in its torque mode during line power supply loss, or when the controlled mode standard ramp is active and the drive is decelerating, to regulate the flow of current into the drive.

00.040 {05.012}		Auto-tune											
RW	Num						NC						
OL	↕	0 to 2					⇒	0					
RFC-A	↕	0 to 5					⇒						
RFC-S	↕	0 to 6					⇒						

### Open-Loop

There are two autotune tests available in open loop mode, a stationary and a rotating test. A rotating autotune should be used whenever possible so the measured value of power factor of the motor is used by the drive.

- A stationary autotune can be used when the motor is loaded and it is not possible to remove the load from the motor shaft. The stationary test measures the *Stator Resistance* (05.017), *Transient Inductance* (05.024), *Voltage Offset At Zero Current* (05.058), *Maximum Voltage Offset* (05.059) and *Current At Maximum Voltage Offset* (05.060) which are required for good performance in vector control modes (see *Open Loop Control Mode* (00.007), later in this table). The stationary autotune does not measure the power factor of the motor so the value on the motor nameplate must be entered into Pr **00.043**. To perform a Stationary autotune, set Pr **00.040** to 1, and provide the drive with both an enable signal (terminal 31 on *Unidrive HS70 / HS71* and terminal 11 and 13 on *Unidrive HS72*) and a run signal (terminal 26 or 27 on *Unidrive HS70 / HS71* and terminal 7 or 8 on *Unidrive HS72*).
- A rotating autotune should only be used if the motor is unloaded. A rotating autotune first performs a stationary autotune, as above, then a rotating test is performed in which the motor is accelerated with currently selected ramps up to a frequency of *Rated Frequency* (05.006) x 2/3, and the frequency is maintained at that level for 4 seconds. *Stator Inductance* (05.025) is measured and this value is used in conjunction with other motor parameters to calculate *Rated Power Factor* (05.010). To perform a Rotating autotune, set Pr **00.040** to 2, and provide the drive with both an enable signal (terminal 31 on *Unidrive HS70 / HS71* and terminal 11 & 13 on *Unidrive HS72*) and a run signal (terminal 26 or 27 on *Unidrive HS70 / HS71* and terminal 7 or 8 on *Unidrive HS72*).

Following the completion of an autotune test the drive will go into the inhibit state. The drive must be placed into a controlled disable condition before the drive can be made to run at the required reference. The drive can be put in to a controlled disable condition by removing the SAFE TORQUE OFF signal from terminal 31 on *Unidrive HS70 / HS71* and terminal 11 & 13 on *Unidrive HS72*, setting the *Drive Enable* (06.015) to OFF (0) or disabling the drive via the *Control Word* (06.042) and *Control Word Enable* (06.043).

### RFC-A

There are three autotune tests available in RFC-A mode, a stationary test, a rotating test and an inertia measurement test. A stationary autotune will give moderate performance whereas a rotating autotune will give improved performance as it measures the actual values of the motor parameters required by the drive. An inertia measurement test should be performed separately to a stationary or rotating autotune.

#### NOTE

It is highly recommended that a rotating autotune is performed (Pr **00.040** set to 2).

- A stationary autotune can be used when the motor is loaded and it is not possible to remove the load from the motor shaft. The stationary autotune measures the *Stator Resistance* (05.017) and *Transient Inductance* (05.024) of the motor. These are used to calculate the current loop gains, and at the end of the test the values in Pr **04.013** and Pr **04.014** are updated. A stationary autotune does not measure the power factor of the motor so the value on the motor nameplate must be entered into Pr **00.043**. To perform a Stationary autotune, set Pr **00.040** to 1, and provide the drive with both an enable signal (terminal 31 on *Unidrive HS70 / HS71* and terminal 11 & 13 on *Unidrive HS72*) and a run signal (terminal 26 or 27 on *Unidrive HS70 / HS71* and terminal 7 or 8 on *Unidrive HS72*).
- A rotating autotune should only be used if the motor is unloaded. A rotating autotune first performs a stationary autotune, a rotating test is then performed which the motor is accelerated with currently selected ramps up to a frequency of *Rated Frequency* (05.006) x 2/3, and the frequency is maintained at the level for up to 40 s. During the rotating autotune the *Stator Inductance* (05.025), and the motor saturation breakpoints (Pr **05.029**, Pr **05.030**, Pr **06.062** and Pr **05.063**) are modified by the drive. The power factor is also modified for user information only, but is not used after this point as the stator inductance is used in the vector control algorithm instead. To perform a Rotating autotune, set Pr **00.040** to 2, and provide the drive with both an enable signal (terminal 31 on *Unidrive HS70 / HS71* and terminal 11 and 13 on *Unidrive HS72*) and a run signal (terminal 26 or 27 on *Unidrive HS70 / HS71* and terminal 7 or 8 on *Unidrive HS72*).

Following the completion of an autotune test the drive will go into the inhibit state. The drive must be placed into a controlled disable condition before the drive can be made to run at the required reference. The drive can be put in to a controlled disable condition by removing the SAFE TORQUE OFF signal from terminal 31 on *Unidrive HS70 / HS71* and terminal 11 and 13 on *Unidrive HS72*, setting the *Drive Enable* (06.015) to OFF (0) or disabling the drive via the control word (Pr **06.042** & Pr **06.043**).

## RFC-S

There are four autotune tests available in RFC-S mode, a stationary autotune, a rotating autotune, an inertia measurement test and a locked rotor test to measure load dependent parameters.

### • Stationary Autotune

The stationary autotune can be used when the motor is loaded and it is not possible uncouple the load from motor shaft. This test can be used to measure all the necessary parameters for basic control. During the stationary autotune, a test is performed to locate the flux axis of the motor. However this test may not be able to calculate such an accurate value for the *Position Feedback Phase Angle* (03.025) as compared to rotating autotune. A stationary test is performed to measure *Stator Resistance* (05.017), *Ld* (05.024), *Voltage Offset At Zero Current* (05.058), *Maximum Voltage Offset* (05.059), *Current At Maximum Voltage Offset* (05.060), *No Load Lq* (05.068) and *No Load Phase Offset* (05.070). If *Enable Stator Compensation* (05.049) = 1 then *Stator Base Temperature* (05.048) is made equal to *Stator Temperature* (05.046). The *Stator Resistance* (05.017) and the *Ld* (05.024) are then used to set up *Current controller Kp Gain* (04.013) and *Current Controller Ki Gain* (04.014). If sensorless mode is not selected then *Position Feedback Phase Angle* (03.025) is set up for the position from the position feedback interface selected with *Motor Control Feedback Select* (03.026). To perform a Stationary autotune, set Pr **00.040** to 1, and provide the drive with both an enable signal (terminal 31 on *Unidrive HS70 / HS71* and terminal 11 & 13 on *Unidrive HS72*) and a run signal (terminal 26 or 27 on *Unidrive HS70 / HS71* and terminal 7 or 8 on *Unidrive HS72*).

### • Rotating Autotune

The rotating autotune must be performed on unloaded motor. This test can be used to measure all the necessary parameters for the basic control and parameters for cancelling the effects of the cogging torque. During the rotating autotune, *Rated Current* (05.007) is applied and the motor is rotated by 2 electrical revolutions (i.e. up to 2 mechanical revolutions) in the required direction. If sensorless mode is not selected then the *Position Feedback Phase Angle* (03.025) is set-up for the position from the position feedback interface selected with *Motor Control Feedback Select* (03.026). A stationary test is then performed to measure *Stator Resistance* (05.017), *Ld* (05.024), *Voltage Offset At Zero Current* (05.058), *Maximum Voltage Offset* (05.059), *Current At Maximum Voltage Offset* (05.060) and *No Load Lq* (05.068). *Stator Resistance* (05.017) and *Ld* (05.024) are used to set up *Current Controller Kp Gain* (04.013) and *Current Controller Ki Gain* (04.014). This is only done once during the test, and so the user can make further adjustments to the current controller gains if required. After a delay of 5 s the motor is rotated through a further electrical revolution and *Cogging Data Parameter 1* (05.074) to *Cogging Data Parameter 8* (05.081) are measured. To perform a Rotating autotune, set Pr **00.040** to 2, and provide the drive with both an enable signal (terminal 31 on *Unidrive HS70 / HS71* and terminal 11 and 13 on *Unidrive HS72*) and a run signal (terminal 26 or 27 on *Unidrive HS70 / HS71* and terminal 7 or 8 on *Unidrive HS72*).

00.041 {05.018}		Maximum Switching Frequency						
RW	Num					NC		
OL	↕	2 kHz (0), 3 kHz (1), 4 kHz (2), 6 kHz (3), 8 kHz (4), 12 kHz (5), 16 kHz (6)			⇒	3 kHz (1)		
RFC-A					⇒	6 kHz (3)		
RFC-S					⇒			

This parameter defines the required switching frequency. The drive may automatically reduce the actual switching frequency (without changing this parameter) if the power stage becomes too hot. A thermal model of the IGBT junction temperature is used based on the heatsink temperature and an instantaneous temperature drop using the drive output current and switching frequency. The estimated IGBT junction temperature is displayed in Pr **07.034**. If the temperature exceeds

145 °C the switching frequency is reduced if this is possible (i.e >3 kHz). Reducing the switching frequency reduces the drive losses and the junction temperature displayed in Pr **07.034** also reduces. If the load condition persists the junction temperature may continue to rise again above 145 °C and the drive cannot reduce the switching frequency further the drive will initiate an 'OHT Inverter' trip. Every second the drive will attempt to restore the switching frequency to the level set in Pr **00.041**.

The full range of switching frequencies is not available on all ratings of Unidrive HS. See section 7.5 *Switching frequency* on page 87, for the maximum available switching frequency for each drive rating.

## 5.3.7 Motor parameters

00.042 {05.011}		Number Of Motor Poles						
RW	Num						US	
OL	↕	Automatic (0) to 480 Poles (240)			⇒	Automatic (0)		
RFC-A					⇒	6 Poles (3)		
RFC-S					⇒			

### Open-loop

This parameter is used in the calculation of motor speed, and in applying the correct slip compensation. When Automatic (0) is selected, the number of motor poles is automatically calculated from the *Rated Frequency* (00.047) and the *Rated Speed rpm* (00.045). The number of poles = 120 \* rated frequency / rpm rounded to the nearest even number.

### RFC-A

This parameter must be set correctly for the vector control algorithms to operate correctly. When Automatic (0) is selected, the number of motor poles is automatically calculated from the *Rated Frequency* (00.047) and the *Rated Speed rpm* (00.045) rpm. The number of poles = 120 \* rated frequency / rpm rounded to the nearest even number.

### RFC-S

This parameter must be set correctly for the vector control algorithms to operate correctly. When auto is selected the number of poles is set to 6.

00.043 {05.010}		Rated Power Factor (OL)						
00.043 {03.025}		Position Feedback Phase Angle (RFC)						
RW	Num						US	
OL	↕	0.000 to 1.000			⇒	0.850		
RFC-A	↕	0.000 to 1.000			⇒	0.850		
RFC-S	↕	0.0 to 359.9 °			⇒			

The power factor is the true power factor of the motor, i.e. the angle between the motor voltage and current.

### Open-loop

The power factor is used in conjunction with the motor rated current (Pr **00.046**) to calculate the rated active current and magnetizing current of the motor. The rated active current is used extensively to control the drive, and the magnetizing current is used in vector mode Rs compensation. It is important that this parameter is set up correctly.

This parameter is obtained by the drive during a rotational autotune. If a stationary autotune is carried out, then the nameplate value should be entered in Pr **00.043**.

### RFC-A

If the stator inductance (Pr **05.025**) contains a non-zero value, the power factor used by the drive is continuously calculated and used in the vector control algorithms (this will not update Pr **00.043**).

If the stator inductance is set to zero (Pr **05.025**) then the power factor written in Pr **00.043** is used in conjunction with the motor rated current

and other motor parameters to calculate the rated active and magnetizing currents which are used in the vector control algorithm.

This parameter is obtained by the drive during a rotational autotune. If a stationary autotune is carried out, then the nameplate value should be entered in Pr **00.043**.

### RFC-S

The phase angle between the rotor flux in a servo motor and the encoder position is required for the motor to operate correctly. If the phase angle is known it can be set in this parameter by the user. Alternatively the drive can automatically measure the phase angle by performing a phasing test (see autotune in RFC-S mode Pr **00.040**). When the test is complete the new value is written to this parameter. The encoder phase angle can be modified at any time and becomes effective immediately. This parameter has a factory default value of 0.0, but is not affected when defaults are loaded by the user.

00.044 {05.009} Rated Voltage	
RW	Num
OL	200 V drive: 230 V 50Hz default 400 V drive: 400 V 60Hz default 400 V drive: 460 V
RFC-A	575 V drive: 575 V 690 V drive: 690 V
RFC-S	

### Open-loop and RFC-A

Enter the value from the rating plate of the motor.

00.045 {05.008} Rated Speed (OL)	
00.045 {04.015} Motor Thermal Time Constant 1 (RFC)	
RW	Num
OL	0 to 180000 rpm
RFC-A	0.00 to 50000.00 rpm
RFC-S	1.0 to 3000.0 s

### Open-loop

This is the speed at which the motor would rotate when supplied with its base frequency at rated voltage, under rated load conditions (= synchronous speed - slip speed). Entering the correct value into this parameter allows the drive to increase the output frequency as a function of load in order to compensate for this speed drop.

Slip compensation is disabled if Pr **00.045** is set to 0 or to synchronous speed, or if Pr **05.027** is set to 0.

If slip compensation is required this parameter should be set to the value from the rating plate of the motor, which should give the correct rpm for a hot machine. Sometimes it will be necessary to adjust this when the drive is commissioned because the nameplate value may be inaccurate. Slip compensation will operate correctly both below base speed and within the field weakening region. Slip compensation is normally used to correct for the motor speed to prevent speed variation with load. The rated load rpm can be set higher than synchronous speed to deliberately introduce speed droop. This can be useful to aid load sharing with mechanically coupled motors.

### RFC-A

Rated load rpm is used with motor rated frequency to determine the full load slip of the motor which is used by the vector control algorithm. Incorrect setting of this parameter can result in the following:

- Reduced efficiency of motor operation
- Reduction of maximum torque available from the motor
- Failure to reach maximum speed
- Over-current trips
- Reduced transient performance
- Inaccurate control of absolute torque in torque control modes

The nameplate value is normally the value for a hot machine, however, some adjustment may be required when the drive is commissioned if the nameplate value is inaccurate.

The rated full load rpm can be optimized by the drive (For further information, refer to section 7.1.2 *RFC-A mode* on page 80).

### RFC-S

Pr **00.045** is the motor thermal time constant of the motor, and is used (along with the motor rated current Pr **00.046**, and total motor current Pr **00.012**) in the thermal model of the motor in applying thermal protection to the motor.

Setting this parameter to 0 disables the motor thermal protection.

For further details, refer to section 7.4 *Motor thermal protection* on page 86.

00.046 {05.007} Rated Current	
RW	Num
OL	Maximum Heavy Duty Rating (11.032)
RFC-A	
RFC-S	

Enter the name-plate value for the motor rated current.

00.047 {05.006} Rated Frequency	
RW	Num
OL	0.0 to 3000.0 Hz
RFC-A	0.0 to 1667.0 Hz
RFC-S	

### Open-loop and RFC-A

Enter the value from the rating plate of the motor.

## 5.3.8 Operating-mode selection

00.048 {01.031} User Drive Mode	
RW	Txt
OL	Open-loop (1)
RFC-A	Open-loop (1), RFC-A (2), RFC-S (3), Regen (4)
RFC-S	RFC-S (3)

The settings for Pr **0.48** are as follows:

Setting	Operating mode
1	Open-loop
2	RFC-A
3	RFC-S
4	Regen

This parameter defines the drive operating mode. Pr **mm.000** must be set to '1253' (European defaults) or '1254' (USA defaults) before this parameter can be changed. When the drive is reset to implement any change in this parameter, the default settings of all parameters will be set according to the drive operating mode selected and saved in memory.

### 5.3.9 Status information

00.049 {11.044} User Security Status	
RW	Txt
OL	Menu 0 (0), All Menus (1), Read-only Menu 0 (2), Read-only (3), Status Only (4), No Access (5)
RFC-A	↕
RFC-S	⇒ Menu 0 (0)

This parameter controls access via the drive keypad as follows:

Security level	Description
0 (Menu 0)	All writable parameters are available to be edited but only parameters in Menu 0 are visible.
1 (All Menus)	All writable parameters are visible and available to be edited.
2 (Read-only Menu 0)	All parameters are read-only. Access is limited to Menu 0 parameters only.
3 (Read-only)	All parameters are read-only however all menus and parameters are visible.
4 (Status Only)	The keypad remains in status mode and no parameters can be viewed or edited.
5 (No Access)	The keypad remains in status mode and no parameters can be viewed or edited. Drive parameters cannot be accessed via a comms / fieldbus interface in the drive or any option module.

The keypad can adjust this parameter even when user security is set.

00.050 {11.029} Software Version	
RO	Num
OL	
RFC-A	↕
RFC-S	⇒ 0 to 99999999

The parameter displays the software version of the drive.

00.051 {10.037} Action On Trip Detection	
RW	Bin
OL	
RFC-A	↕
RFC-S	⇒ 0 to 31

Each bit in this parameter has the following functions:

Bit	Function
0	Stop on non-important trips
1	Disable braking resistor overload detection
2	Disable phase loss stop
3	Disable braking resistor temperature monitoring
4	Disable parameter freeze on trip

#### Example

Pr 10.037=8 (1000<sub>binary</sub>) Th Brake Res trip is disabled

Pr 10.037=12 (1100<sub>binary</sub>) Th Brake Res and phase loss trip is disabled

#### Stop on non-important trips

If bit 0 is set to one the drive will attempt to stop before tripping if any of the following trip conditions are detected: I/O Overload, An Input 1 Loss, An Input 2 Loss or Keypad Mode.

#### Disable braking resistor overload detection

For details of braking resistor overload detection mode see Pr 10.030.

#### Disable phase loss trip

Normally the drive will stop when the input phase loss condition is detected. If this bit is set to 1 the drive will continue to run and will only trip when the drive is brought to a stop by the user.

#### Disable braking resistor temperature monitoring

Size 3, 4 and 5 drives have an internal user install braking resistor with a thermistor to detect overheating of the resistor. As default bit 3 of Pr 10.037 is set to zero, and so if the braking resistor and its thermistor is not installed the drive will produce a trip (Th Brake Res) because the thermistor appears to be open-circuit. This trip can be disabled so that the drive can run by setting bit 3 of Pr 10.037 to one. If the resistor is installed then no trip is produced unless the thermistor fails, and so bit 3 of Pr 10.037 can be left at zero. This feature only applies to size 3, 4 and 5 drives. For example if Pr 10.037 = 8, then Th Brake Res trip will be disabled.

#### Disable parameter freeze on trip

If this bit is 0 then the parameters listed below are frozen on trip until the trip is cleared. If this bit is 1 then this feature is disabled.

Open-loop mode	RFC-A and RFC-S modes
Reference Selected (01.001)	Reference Selected (01.001)
Pre-skip Filter Reference (01.002)	Pre-skip Filter Reference (01.002)
Pre-ramp Reference (01.003)	Pre-ramp Reference (01.003)
Post Ramp Reference (02.001)	Post Ramp Reference (02.001)
Frequency Slaving Demand (03.001)	Final Speed Reference (03.001)
	Speed Feedback (03.002)
	Speed Error (03.003)
	Speed Controller Output (03.004)
Current Magnitude (04.001)	Current Magnitude (04.001)
Torque Producing Current (04.002)	Torque Producing Current (04.002)
Magnetising Current (04.017)	Magnetising Current (04.017)
Output Frequency (05.001)	Output Frequency (05.001)
Output Voltage (05.002)	Output Voltage (05.002)
Output Power (05.003)	Output Power (05.003)
D.c. Bus Voltage (05.005)	D.c. Bus Voltage (05.005)
Analog Input 1 (07.001)*	Analog Input 1 (07.001)*
Analog Input 2 (07.002)*	Analog Input 2 (07.002)*
Analog Input 3 (07.003)*	Analog Input 3 (07.003)*

\*Not applicable to Unidrive HS72

00.052 {11.020} Reset Serial Communications*	
RW	Bit
OL	
RFC-A	↕
RFC-S	⇒ Off (0) or On (1)

\* Only applicable to Unidrive HS71.

When Serial Address (11.023), Serial Mode (11.024), Serial Baud Rate (11.025), Minimum Comms Transmit Delay (11.026) or Silent Period (11.027) are modified the changes do not have an immediate effect on the serial communications system. The new values are used after the next power-up or if Reset Serial Communications (11.020) is set to one. Reset Serial Communications (11.020) is automatically cleared to zero after the communications system is updated.

## 6 Running the motor

This chapter takes the new user through all the essential steps to running a motor for the first time, in each of the possible operating modes.

For information on tuning the drive for the best performance, see *Chapter 7 Optimization* on page 77.



Ensure that no damage or safety hazard could arise from the motor starting unexpectedly.

**WARNING**



The values of the motor parameters affect the protection of the motor. The default values in the drive should not be relied upon. It is essential that the correct value is entered in Pr **00.046 Rated Current**. This affects the thermal protection of the motor.



If the drive is started using the keypad it will run to the speed defined by the keypad reference (Pr **01.017**). This may not be acceptable depending on the application. The user must check in Pr **01.017** and ensure that the keypad reference has been set to 0.



If the intended maximum speed affects the safety of the machinery, additional independent over-speed protection must be used.

**WARNING**

### 6.1 Quick start connections

#### 6.1.1 Basic requirements

This section shows the basic connections which must be made for the drive to run in the required mode. For minimal parameter settings to run in each mode please see the relevant part of section 6.3 *Quick start commissioning / start-up* on page 66.

**Table 6-1 Minimum control connection requirements for each control mode**

Drive control method	Requirements
Terminal mode	Drive enable Speed / Torque reference Run forward / Run reverse
Keypad mode	Drive enable
Serial communications	Drive enable Serial communications link

**Table 6-2 Minimum control connection requirements for each mode of operation**

Operating mode	Requirements
Open loop mode	Induction motor
RFC – A mode (with speed feedback)	Induction motor with speed feedback
RFC - S mode (with speed and position feedback)	Permanent magnet motor with speed and position feedback

#### Speed feedback

Suitable devices are:

- Incremental encoder (A, B or F, D with or without Z)
- Incremental encoder with forward and reverse outputs (F, R with or without Z)
- SINCOS encoder (with, or without Stegmann Hiperface, EnDat or SSI communications protocols)
- BiSS absolute encoder

- EnDat absolute encoder
- Resolver

#### Speed and position feedback

Suitable devices are:

- Incremental encoder (A, B or F, D with or without Z) with commutation signals (U, V, W)
- Incremental encoder with forward and reverse outputs (F, R with or without Z) and commutation outputs (U, V, W)
- SINCOS encoder (with Stegmann Hiperface, EnDat or SSI communications protocols)
- BiSS absolute encoder
- EnDat absolute encoder
- Resolver

### 6.2 Changing the operating mode

Changing the operating mode returns all parameters to their default value, including the motor parameters. *User Security Status* (Pr **00.049**) and *User Security Code* (Pr **00.034**) are not affected by this procedure.

#### Procedure

Use the following procedure only if a different operating mode is required:

1. Enter either of the following values in Pr **mm.000**, as appropriate:
  - 1253 (50 Hz AC supply frequency)
  - 1254 (60 Hz AC supply frequency)
2. Change the setting of Pr **00.048** as follows:

Pr 00.048 setting		Operating mode
	1	Open-loop
	2	RFC-A
	3	RFC-S

The figures in the second column apply when serial communications are used.

3. Either:

- Press the red reset button
- Toggle the reset digital input
- Carry out a drive reset through serial communications by setting Pr **10.038** to 100 (ensure that Pr. **mm.000** returns to 0).

Figure 6-1 Minimum connections to get the motor running in any operating mode for Unidrive HS70 / HS71 (size 3 and 4)

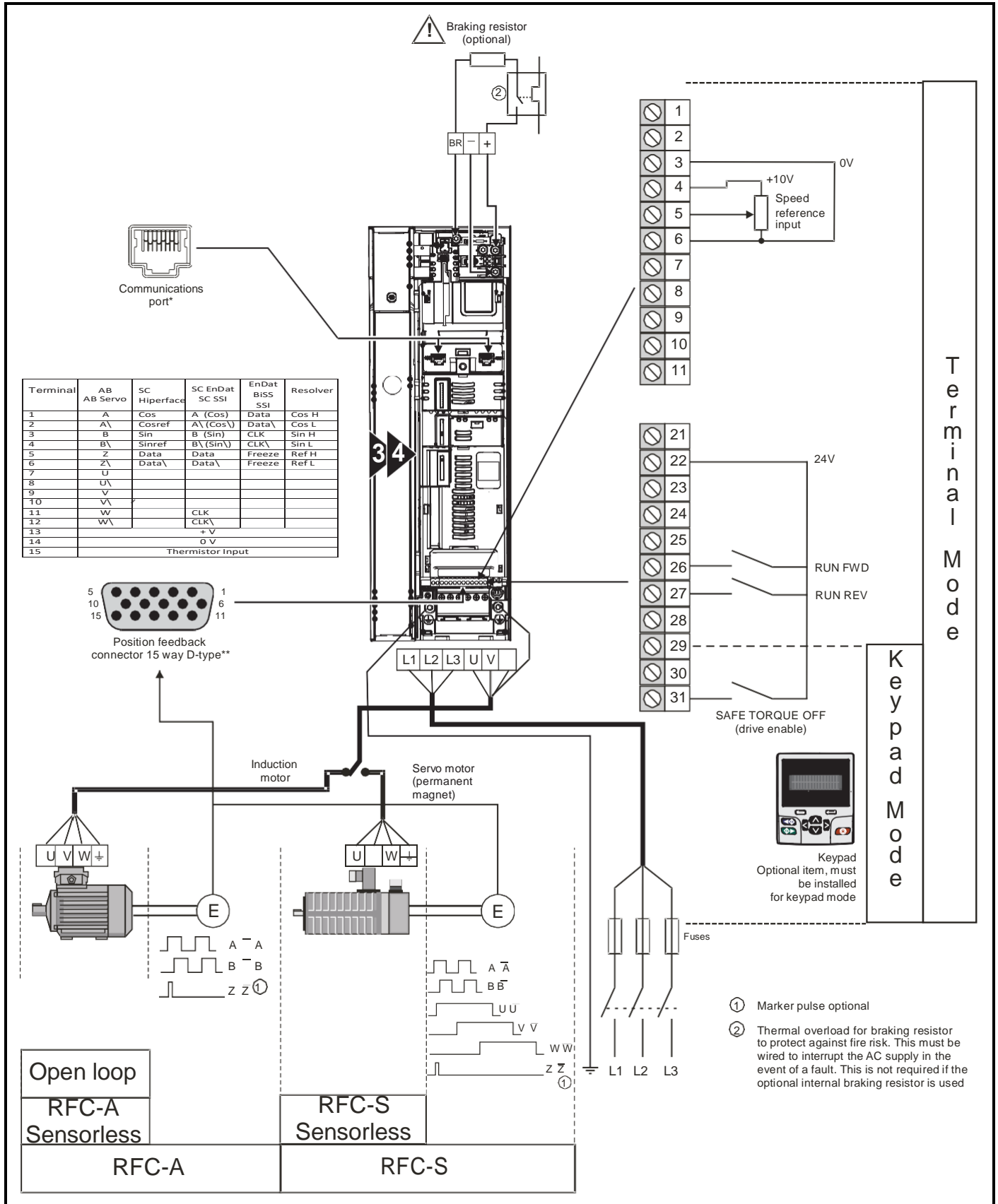

\* Ethernet fieldbus communication ports on Unidrive HS70 and 485 serial communication ports on Unidrive HS71.

\*\* Position feedback port.

Figure 6-2 Minimum connections to get the motor running in any operating mode for Unidrive HS72 (size 3 and 4)

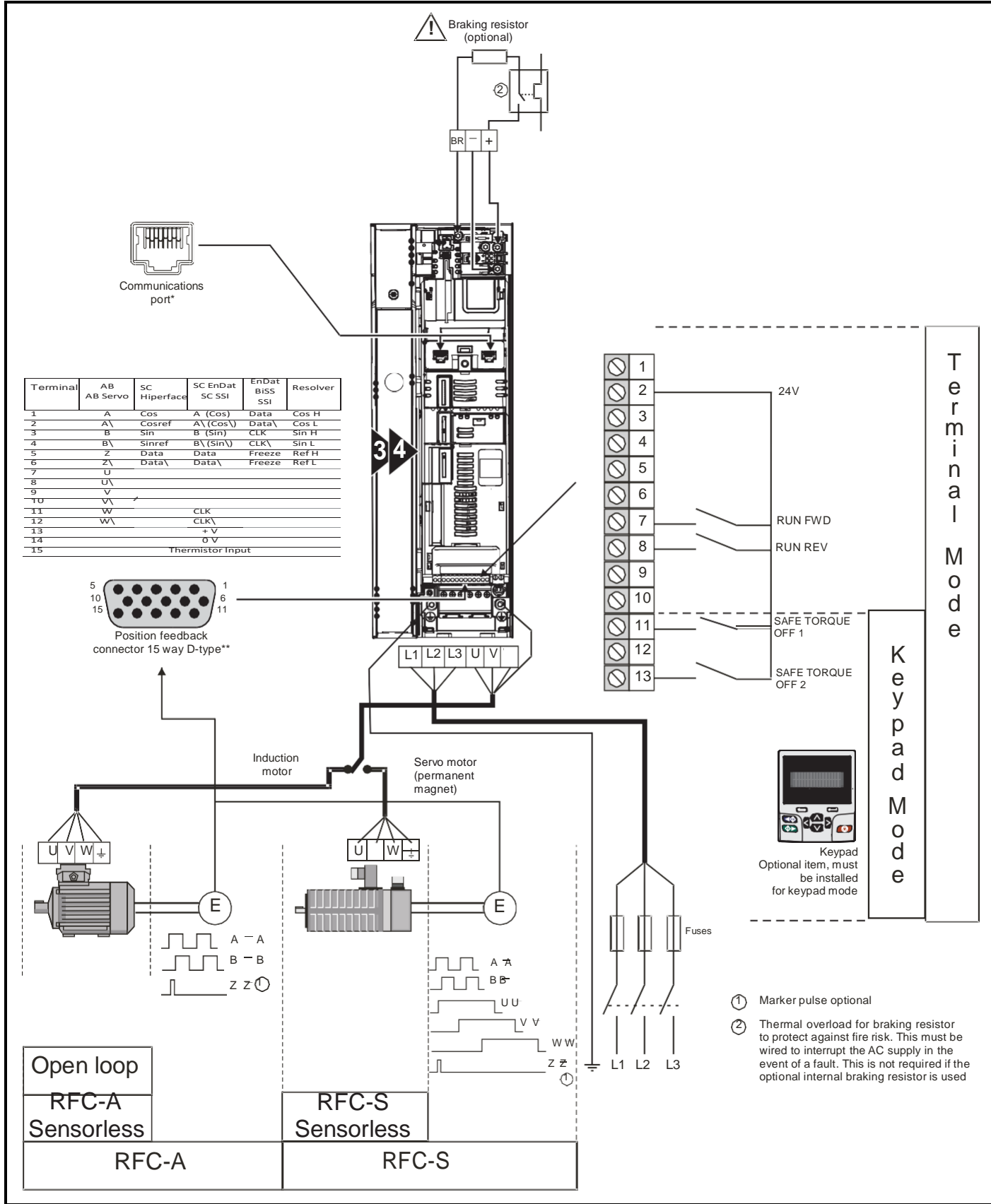

\* Ethernet fieldbus communication ports.

\*\* Position feedback port.

Figure 6-3 Minimum connections to get the motor running in any operating mode for Unidrive HS70 / HS71 (size 7 onwards)

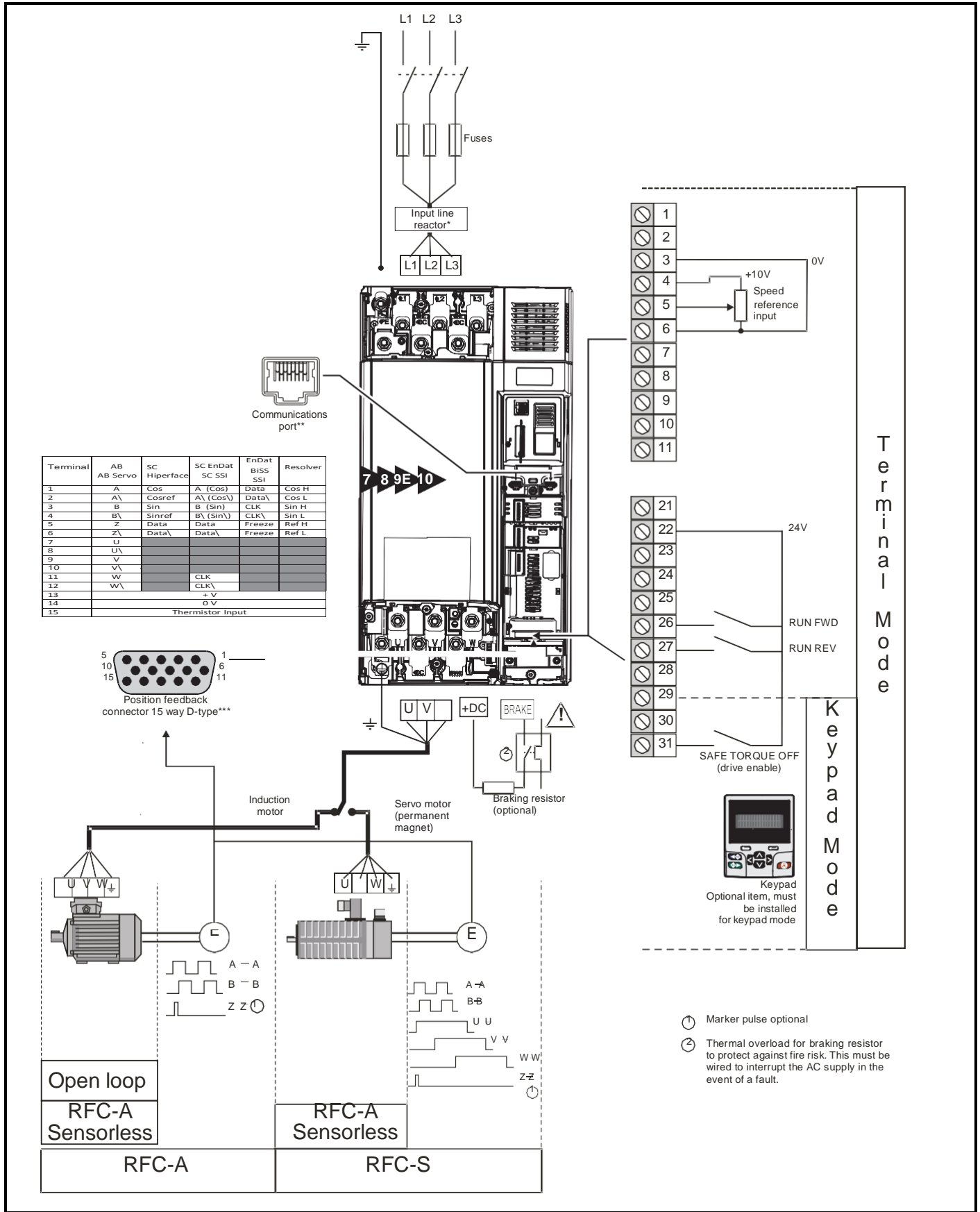

\* Required for size 9E and 10.

\*\* Ethernet fieldbus communication ports on *Unidrive HS70* and 485 serial communication ports on *Unidrive HS71*.

\*\*\* Position feedback port.

Figure 6-4 Minimum connections to get the motor running in any operating mode for Unidrive HS72 (size 7 onwards)

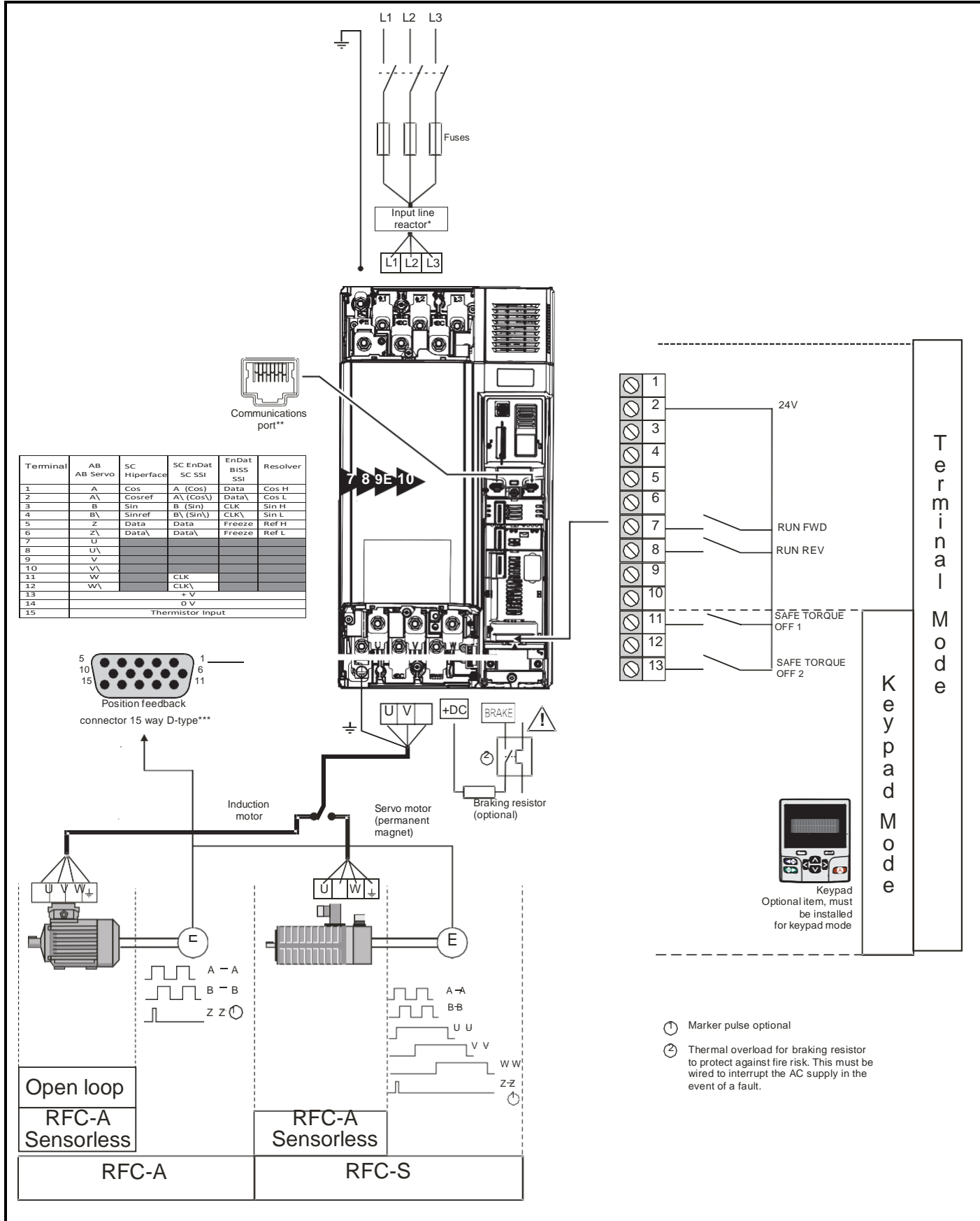







\* Required for size 9E and 10.

\*\* Ethernet fieldbus communication ports.

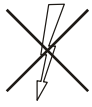
\*\*\* Position feedback port.

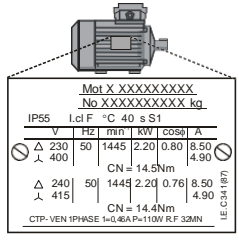
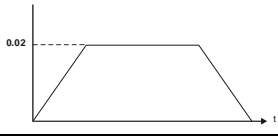
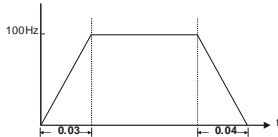
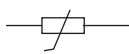
## 6.3 Quick start commissioning / start-up

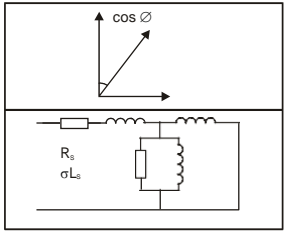







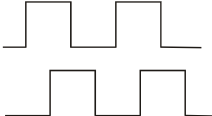

### 6.3.1 Open loop

Action	Detail	
Before power-up	Ensure: <ul style="list-style-type: none"> <li>The drive enable signal is not given (terminal 31 on Unidrive HS70 / HS71 and terminal 11 &amp; 13 on Unidrive HS72).</li> <li>Run signal is not given</li> <li>Motor is connected</li> </ul>	
Power-up the drive	Verify that Open Loop mode is displayed as the drive powers up. If the mode is incorrect see section 4.6 <i>Changing the operating mode</i> on page 37. Ensure: <ul style="list-style-type: none"> <li>Drive displays 'Inhibit'</li> </ul> If the drive trips, see section 12 <i>Diagnostics</i> on page 194.	
Enter motor nameplate details	Enter: <ul style="list-style-type: none"> <li>Motor rated frequency in Pr <b>00.047</b> (Hz)</li> <li>Motor rated current in Pr <b>00.046</b> (A)</li> <li>Motor rated speed in Pr <b>00.045</b> (rpm)</li> <li>Motor rated voltage in Pr <b>00.044</b> (V) - check if <math>\Delta</math> or <math>\Delta</math> connection</li> </ul>	
Set maximum frequency	Enter: <ul style="list-style-type: none"> <li>Maximum frequency in Pr <b>00.002</b> (Hz)</li> </ul>	
Set acceleration / deceleration rates	Enter: <ul style="list-style-type: none"> <li>Acceleration rate in Pr <b>00.003</b> (s/100 Hz)</li> <li>Deceleration rate in Pr <b>00.004</b> (s/100 Hz) (If braking resistor installed, set Pr <b>00.015</b> = Fast. Also ensure Pr <b>10.030</b> and Pr <b>10.031</b> and Pr <b>10.061</b> are set correctly, otherwise premature 'Brake R Too Hot' trips may be seen).</li> </ul>	
Motor thermistor set-up	The motor thermistor connection is made through the drive encoder port (terminal 15). The thermistor type is selected in <i>P1 Thermistor Type</i> (03.118). On Unidrive HS70 / HS71, the motor thermistor can be selected in Pr <b>07.015</b> . Refer to Pr <b>07.015</b> for further information.	
Autotune	<p>The drive is able to perform either a stationary or a rotating autotune. The motor must be at a standstill before an autotune is enabled. A rotating autotune should be used whenever possible so the measured value of power factor of the motor is used by the drive.</p> <p> <b>WARNING</b> A rotating autotune will cause the motor to accelerate up to <math>\frac{2}{3}</math> base speed in the direction selected regardless of the reference provided. Once complete the motor will coast to a stop. The enable signal must be removed before the drive can be made to run at the required reference. The drive can be stopped at any time by removing the run signal or removing the drive enable.</p> <ul style="list-style-type: none"> <li>A stationary autotune can be used when the motor is loaded and it is not possible to uncouple the load from the motor shaft. A stationary autotune measures the stator resistance of the motor and the voltage offset in the drive. These are required for good performance in vector control modes. A stationary autotune does not measure the power factor of the motor so the value on the motor nameplate must be entered into Pr <b>00.043</b>.</li> <li>A rotating autotune should only be used if the motor is uncoupled. A rotating autotune first performs a stationary autotune before rotating the motor at <math>\frac{2}{3}</math> base speed in the direction selected. The rotating autotune measures the power factor of the motor.</li> </ul> <p>To perform an autotune:</p> <ul style="list-style-type: none"> <li>Set Pr <b>00.040</b> = 1 for a stationary autotune or set Pr <b>00.040</b> = 2 for a rotating autotune</li> <li>Close the Drive Enable signal (terminal 31 on Unidrive HS70 / HS71 and terminal 11 &amp; 13 on Unidrive HS72). The drive will display 'Ready'.</li> <li>Close the run signal (terminal 26 or 27 on Unidrive HS70 / HS71 and terminal 7 or 8 on Unidrive HS72). The upper row of the display will flash 'Auto Tune' while the drive is performing the autotune.</li> <li>Wait for the drive to display 'Ready' or 'Inhibit' and for the motor to come to a standstill.</li> </ul> <p>If the drive trips, see Chapter 12 <i>Diagnostics</i> on page 194.</p> <ul style="list-style-type: none"> <li>Remove the drive enable and run signal from the drive.</li> </ul>	
Save parameters	Select 'Save Parameters' in Pr <b>mm.000</b> (alternatively enter a value of 1000 in Pr <b>mm.000</b> ) and press the red  reset button or toggle the reset digital input.	
Run	Drive is now ready to run	

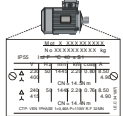
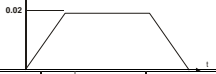
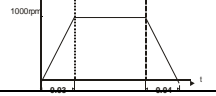
### 6.3.2 RFC - A mode (with position feedback)

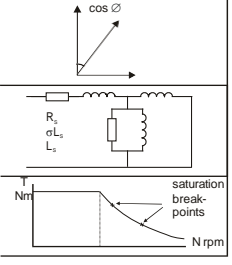
#### Induction motor with position feedback



For simplicity only an incremental quadrature encoder will be considered here. For information on setting up one of the other supported speed feedback devices, refer to section 6.4 *Setting up a feedback device* on page 70.

Action	Detail	
Before power-up	Ensure: <ul style="list-style-type: none"> <li>The drive enable signal is not given (terminal 31 on Unidrive HS70 / HS71 and terminal 11 &amp; 13 on Unidrive HS72).</li> <li>Run signal is not given</li> <li>Motor and feedback device are connected</li> </ul>	
Power-up the drive	Verify that RFC-A mode is displayed as the drive powers up. If the mode is incorrect see section 4.6 <i>Changing the operating mode</i> on page 37. Ensure: <ul style="list-style-type: none"> <li>Drive displays 'Inhibit'</li> </ul> If the drive trips, see Chapter 12 <i>Diagnostics</i> on page 194.	
Set motor feedback parameters	<b>Incremental encoder basic set-up</b> Enter: <ul style="list-style-type: none"> <li>Drive encoder type in Pr <b>03.038</b> = AB (0): Quadrature encoder</li> <li>Encoder power supply in Pr <b>03.036</b> = 5 V (0), 8 V (1) or 15 V (2).</li> </ul> <b>NOTE</b> If output voltage from the encoder is >5 V, then the termination resistors must be disabled Pr <b>03.039</b> to 0.	
	 Setting the encoder voltage supply too high for the encoder could result in damage to the feedback device. <ul style="list-style-type: none"> <li>Drive encoder Lines Per Revolution (LPR) in Pr <b>03.034</b> (set according to encoder)</li> <li>Drive encoder termination resistor setting in Pr <b>03.039</b>: <ul style="list-style-type: none"> <li><b>0</b> = A-A\, B-B\, Z-Z\ termination resistors disabled</li> <li><b>1</b> = A-A\, B-B\, termination resistors enabled, Z-Z\ termination resistors disabled</li> <li><b>2</b> = A-A\, B-B\, Z-Z\ termination resistors enabled</li> </ul> </li> </ul>	
Enter motor nameplate details	<ul style="list-style-type: none"> <li>Motor rated frequency in Pr <b>00.047</b> (Hz)</li> <li>Motor rated current in Pr <b>00.046</b> (A)</li> <li>Motor rated speed in Pr <b>00.045</b> (rpm)</li> <li>Motor rated voltage in Pr <b>00.044</b> (V) - check if <math>\Delta</math> or <math>\Lambda</math> connection</li> </ul>	
Set maximum speed	Enter: Maximum speed in Pr <b>00.002</b> (rpm)	
Set acceleration / deceleration rates	Enter: <ul style="list-style-type: none"> <li>Acceleration rate in Pr <b>00.003</b> (s/1000 rpm)</li> <li>Deceleration rate in Pr <b>00.004</b> (s/1000 rpm) (If braking resistor installed, set Pr <b>00.015</b> = Fast. Also ensure Pr <b>10.030</b>, Pr <b>10.031</b> and Pr <b>10.061</b> are set correctly, otherwise premature 'Brake R Too Hot' trips may be seen).</li> </ul>	
Motor thermistor set-up	The motor thermistor connection is made through the drive encoder port (terminal 15). The thermistor type is selected in <i>P1 Thermistor Type</i> (03.118). On Unidrive HS70 / HS71, the motor thermistor can be selected in Pr <b>07.015</b> . Refer to Pr <b>07.015</b> for further information.	
Autotune	The drive is able to perform either a stationary or a rotating autotune. The motor must be at a standstill before an autotune is enabled. A stationary autotune will give moderate performance whereas a rotating autotune will give improved performance as it measures the actual values of the motor parameters required by the drive.	
	 A rotating autotune will cause the motor to accelerate up to $2/3$ base speed in the direction selected regardless of the reference provided. Once complete the motor will coast to a stop. The enable signal must be removed before the drive can be made to run at the required reference. <b>WARNING</b> The drive can be stopped at any time by removing the run signal or removing the drive enable. <ul style="list-style-type: none"> <li>A stationary autotune can be used when the motor is loaded and it is not possible to uncouple the load from the motor shaft. The stationary autotune measures the stator resistance and transient inductance of the motor. These are used to calculate the current loop gains, and at the end of the test the values in Pr <b>00.038</b> and Pr <b>00.039</b> are updated. A stationary autotune does not measure the power factor of the motor so the value on the motor nameplate must be entered into Pr <b>00.043</b>.</li> <li>A rotating autotune should only be used if the motor is uncoupled. A rotating autotune first performs a stationary autotune before rotating the motor at <math>2/3</math> base speed in the direction selected. The rotating autotune measures the stator inductance of the motor and calculates the power factor.</li> </ul> To perform an autotune: <ul style="list-style-type: none"> <li>Set Pr <b>00.040</b> = 1 for a stationary autotune or set Pr <b>00.040</b> = 2 for a rotating autotune</li> <li>Close the drive enable signal (terminal 31 on Unidrive HS70 / HS71 and terminal 11 &amp; 13 on Unidrive HS72). The drive will display 'Ready'.</li> <li>Close the run signal (terminal 26 or 27 on Unidrive HS70 / HS71 and terminal 7 or 8 on Unidrive HS72). The upper row of the display will flash 'Auto Tune' while the drive is performing the autotune.</li> <li>Wait for the drive to display 'Ready' or 'Inhibit' and for the motor to come to a standstill</li> </ul> If the drive trips, see Chapter 12 <i>Diagnostics</i> on page 194. <ul style="list-style-type: none"> <li>Remove the drive enable and run signal from the drive.</li> </ul>	
Save parameters	Select 'Save Parameters' in Pr <b>mm.000</b> (alternatively enter a value of 1000 in Pr <b>mm.000</b> ) and press red 	
Run	Drive is now ready to run	

### 6.3.3 RFC-A mode (Sensorless control)

#### Induction motor with sensorless control



Action	Detail	
Before power-up	Ensure: <ul style="list-style-type: none"> <li>The drive enable signal is not given (terminal 31 on Unidrive HS70 / HS71 and terminal 11 &amp; 13 on Unidrive HS72).</li> <li>Run signal is not given</li> <li>Motor is connected</li> </ul>	
Power-up the drive	Verify that RFC-A mode is displayed as the drive powers up. If the mode is incorrect see section 4.6 <i>Changing the operating mode</i> on page 37. Ensure: <ul style="list-style-type: none"> <li>Drive displays 'Inhibit'</li> </ul> If the drive trips, see Chapter 12 <i>Diagnostics</i> on page 194.	
Select RFC-A (Sensorless control) mode and disable wire-encoder wire-break trip	<ul style="list-style-type: none"> <li>Set Pr <b>03.024</b> = 1 or 3 to select RFC-A Sensorless mode</li> <li>Set Pr <b>03.040</b> = 0000 to disable the wire break</li> </ul>	
Enter motor nameplate details	Enter: <ul style="list-style-type: none"> <li>Motor rated frequency in Pr <b>00.047</b> (Hz)</li> <li>Motor rated current in Pr <b>00.046</b> (A)</li> <li>Motor rated speed in Pr <b>00.045</b> (rpm)</li> <li>Motor rated voltage in Pr <b>00.044</b> (V) - check if <math>\Delta</math> or <math>Y</math> connection</li> </ul>	
Set maximum speed	Enter: <ul style="list-style-type: none"> <li>Maximum speed in Pr <b>00.002</b> (rpm)</li> </ul>	
Set acceleration / deceleration rates	Enter: <ul style="list-style-type: none"> <li>Acceleration rate in Pr <b>00.003</b> (s/1000rpm)</li> <li>Deceleration rate in Pr <b>00.004</b> (s/1000rpm) (If braking resistor installed, set Pr <b>00.015</b> = Fast. Also ensure Pr <b>10.030</b>, Pr <b>10.031</b> and Pr <b>10.061</b> are set correctly, otherwise premature 'Brake R Too Hot' trips may be seen).</li> </ul>	
Motor thermistor set-up	The motor thermistor connection is made through the drive encoder port (terminal 15). The thermistor type is selected in <i>P1 Thermistor Type</i> (03.118). On Unidrive HS70 / HS71, the motor thermistor can be selected in Pr <b>07.015</b> . Refer to Pr <b>07.015</b> for further information.	
Select or deselect catch a spinning motor mode	If catch a spinning motor mode is not required then set Pr <b>06.009</b> to 0. If catch a spinning motor mode is required then leave Pr <b>06.009</b> at the default of 1, but depending on the size of the motor the value in Pr <b>05.040</b> may need to be adjusted. Pr <b>05.040</b> defines a scaling function used by the algorithm that detects the speed of the motor. The default value of Pr <b>05.040</b> is 1 which is suitable for small motors (<4 kW). For larger motors the value in Pr <b>05.040</b> will need to be increased. Approximate values of Pr <b>05.040</b> for different motor sizes are as follows, 2 for 11 kW, 3 for 55 kW and 5 for 150 kW. If the value of Pr <b>05.040</b> is too large the motor may accelerate from standstill when the drive is enabled. If the value of this parameter is too small the drive will detect the motor speed as zero even if the motor is spinning.	
Autotune	<p>The drive is able to perform either a stationary or a rotating autotune. The motor must be at a standstill before an autotune is enabled. A stationary autotune will give moderate performance whereas a rotating autotune will give improved performance as it measures the actual values of the motor parameters required by the drive.</p> <p><b>NOTE</b> It is highly recommended that a rotating autotune is performed (Pr <b>00.040</b> set to 2).</p> <div style="border: 1px solid black; padding: 5px; margin: 10px 0;"> <p>A rotating autotune will cause the motor to accelerate up to <math>2/3</math> base speed in the direction selected regardless of the reference provided. Once complete the motor will coast to a stop. The enable signal must be removed before the drive can be made to run at the required reference. The drive can be stopped at any time by removing the run signal or removing the drive enable.</p> </div> <ul style="list-style-type: none"> <li>A stationary autotune can be used when the motor is loaded and it is not possible to uncouple the load from the motor shaft. The stationary autotune measures the stator resistance and transient inductance of the motor. These are used to calculate the current loop gains, and at the end of the test the values in Pr <b>00.038</b> and Pr <b>00.039</b> are updated. A stationary autotune does not measure the power factor of the motor so the value on the motor nameplate must be entered into Pr <b>00.043</b>.</li> <li>A rotating autotune should only be used if the motor is uncoupled. A rotating autotune first performs a stationary autotune before rotating the motor at <math>2/3</math> base speed in the direction selected. The rotating autotune measures the stator inductance of the motor and calculates the power factor.</li> </ul> <p>To perform an autotune:</p> <ul style="list-style-type: none"> <li>Set Pr <b>00.040</b> = 1 for a stationary autotune or set Pr <b>00.040</b> = 2 for a rotating autotune</li> <li>Close the drive enable signal (terminal 31 on Unidrive HS70 / HS71 and terminal 11 &amp; 13 on Unidrive HS72). The drive will display 'Ready' or 'Inhibit'.</li> <li>Close the run signal (terminal 26 or 27 on Unidrive HS70 / HS71 and terminal 7 or 8 on Unidrive HS72). The upper row of the display will flash 'Auto Tune' while the drive is performing the autotune.</li> <li>Wait for the drive to display 'Ready' or 'Inhibit' and for the motor to come to a standstill.</li> </ul> <p>If the drive trips, see Chapter 12 <i>Diagnostics</i> on page 194.</p> <ul style="list-style-type: none"> <li>Remove the drive enable and run signal from the drive.</li> </ul>	





Action	Detail
Save parameters	Select 'Save Parameters' in Pr <b>MM.000</b> (alternatively enter a value of 1000 in Pr <b>MM.000</b> ) and press red 
Run	Drive is now ready to run 

### 6.3.4 RFC-S mode (with position feedback)

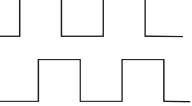
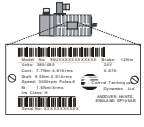
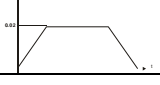
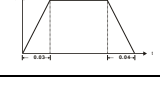
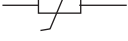
#### Permanent magnet motor with position feedback

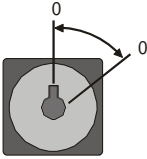
For simplicity only an incremental quadrature encoder with commutation outputs will be considered here. For information on setting up one of the other supported speed feedback devices, refer to section 6.4 *Setting up a feedback device* on page 70.

Action	Detail
Before power-up	Ensure: <ul style="list-style-type: none"> <li>The drive enable signal is not given (terminal 31 on Unidrive HS70 / HS71 and terminal 11 &amp; 13 on Unidrive HS72).</li> <li>Run signal is not given</li> <li>Motor and feedback device are connected</li> </ul> 
Power-up the drive	Verify that RFC-S mode is displayed as the drive powers up. If the mode is incorrect see section 4.6 <i>Changing the operating mode</i> on page 37. Ensure: <ul style="list-style-type: none"> <li>Drive displays 'inhibit'</li> </ul> If the drive trips, see Chapter 12 <i>Diagnostics</i> on page 194. 
Set motor feedback parameters	<p><b>Incremental encoder basic set-up</b></p> <p>Enter:</p> <ul style="list-style-type: none"> <li>Drive encoder type in Pr <b>03.038</b> = AB Servo (3): Quadrature encoder with commutation outputs</li> <li>Encoder power supply in Pr <b>03.036</b> = 5 V (0), 8 V (1) or 15 V (2).</li> </ul> <p><b>NOTE</b></p> <p>If output voltage from the encoder is &gt;5 V, then the termination resistors must be disabled Pr <b>03.039</b> to 0.</p> <p> <b>CAUTION</b> Setting the encoder voltage supply too high for the encoder could result in damage to the feedback device.</p>  <ul style="list-style-type: none"> <li>Drive encoder Pulses Per Revolution in Pr <b>03.034</b> (set according to encoder)</li> <li>Drive encoder termination resistor setting in Pr <b>03.039</b>: <ul style="list-style-type: none"> <li>0 = A-A\, B-B\, Z-Z\ termination resistors disabled</li> <li>1 = A-A\, B-B\, termination resistors enabled, Z-Z\ termination resistors disabled</li> <li>2 = A-A\, B-B\, Z-Z\ termination resistors enabled</li> </ul> </li> </ul>
Enter motor nameplate details	Enter: <ul style="list-style-type: none"> <li>Motor rated current in Pr <b>00.046</b> (A)</li> <li>Ensure that this equal to or less than the Heavy Duty rating of the drive otherwise 'Motor Too Hot' trips may occur during the autotune.</li> <li>Number of poles in Pr <b>00.042</b></li> <li>Motor rated voltage in Pr <b>00.044</b> (V)</li> </ul> 
Set maximum speed	Enter: <ul style="list-style-type: none"> <li>Maximum speed in Pr <b>00.002</b> (rpm)</li> </ul> 
Set acceleration / deceleration rates	Enter: <ul style="list-style-type: none"> <li>Acceleration rate in Pr <b>00.003</b> (s/1000 rpm)</li> <li>Deceleration rate in Pr <b>00.004</b> (s/1000 rpm) (If braking resistor installed, set Pr <b>00.015</b> = Fast. Also ensure Pr <b>10.030</b>, Pr <b>10.031</b> and Pr <b>10.061</b> are set correctly, otherwise premature 'Brake R Too Hot' trips may be seen).</li> </ul> 
Motor thermistor set-up	The motor thermistor connection is made through the drive encoder port (terminal 15). The thermistor type is selected in <i>P1 Thermistor Type</i> (03.118). On Unidrive HS70 / HS71, the motor thermistor can be selected in Pr <b>07.015</b> . Refer to Pr <b>07.015</b> for further information. 

Action	Detail
Autotune	<p>The drive is able to perform either a stationary or a rotating autotune. The motor must be at a standstill before an autotune is enabled. A stationary autotune will give moderate performance whereas a rotating autotune will give improved performance as it measures the actual values of the motor parameters required by the drive. The drive is able to perform a stationary, rotating, mechanical load measurement or locked rotor test autotune. The motor must be at a standstill before an autotune is enabled. It is suggested that a rotating auto tune is used for accurate measurement for position feedback phase angle.</p> <ul style="list-style-type: none"> <li>A stationary autotune can be used when the motor is loaded and it is not possible to uncouple the load from the motor shaft. A stationary autotune is performed to locate the flux axis of the motor. The stationary autotune measures the stator resistance, inductance in flux axis, voltage offset at zero current, maximum voltage offset, inductance in torque axis with no load on the motor and current at maximum voltage offset of the motor. These are used to calculate the current loop gains, and at the end of the test the values in Pr <b>00.038</b> and Pr <b>00.039</b> are updated. If Sensorless mode is not selected then <i>Position Feedback Phase Angle</i> (03.025) is set-up for the selected position feedback.</li> <li>A rotating autotune should only be used if the motor is uncoupled. The rotating autotune will rotate the motor by up to 2 mechanical revolutions in the direction selected, regardless of the reference provided to obtain the position feedback phase angle. A stationary autotune is then performed to obtain stator resistance, inductance in flux axis, voltage offset at zero current, maximum voltage offset, inductance in torque axis with no load on the motor and current at maximum voltage offset of the motor. From the above obtained parameters the current loop gains are calculated, and at the end of the test the values in Pr <b>00.038</b> and Pr <b>00.039</b> are updated.</li> </ul> 
	<p> The rotating autotune will rotate the motor by up to 2 mechanical revolutions in the direction selected, regardless of the reference provided. After a short delay, the motor is further rotated through a electrical revolution. The enable signal must be removed before the drive can be made to run at the required reference. The drive can be stopped at any time by removing the run signal or removing the drive enable.</p>
	<p>To perform an autotune:</p> <ul style="list-style-type: none"> <li>Set Pr <b>00.040</b> = 1 for a stationary autotune, Pr <b>00.040</b> = 2 for a rotating autotune.</li> <li>Close the run signal (terminal 26 or 27 on Unidrive HS70 / HS71 and terminal 7 or 8 on Unidrive HS72).</li> <li>Close the drive enable signal (terminal 31 on Unidrive HS70 / HS71 and terminal 11 &amp; 13 on Unidrive HS72). The upper row of the display will flash 'Auto Tune' while the drive is performing the test.</li> <li>Wait for the drive to display 'Ready' or 'Inhibit' and for the motor to come to a standstill.</li> </ul> <p>If the drive trips it cannot be reset until the drive enable signal (terminal 31 on Unidrive HS70 / HS71 and terminal 11 &amp; 13 on Unidrive HS72) has been removed. See section 12 <i>Diagnostics</i> on page 194.</p> <ul style="list-style-type: none"> <li>Remove the drive enabled and run signal from the drive.</li> </ul>
Save parameters	Select 'Save Parameters' in Pr <b>MM.000</b> (alternatively enter a value of 1000 in Pr <b>MM.000</b> ) and press red  reset button or toggle the reset digital input.
Run	Drive is now ready to run 

## 6.4 Setting up a feedback device

### 6.4.1 P1 position interface

This section shows the parameter settings which must be made to use each of the compatible feedback device types with P1 position interface on the drive. For more information on the parameters listed here please refer to the *Parameter Reference Guide*.

**Table 6-3 Parameters required for feedback device set-up on the P1 position interface**

Parameter	AB, FD, FR, AB Servo, FD Servo, FR Servo, SC, SC Servo	SC Hiperface	SC EnDat	EnDat	SC SSI	SSI	BiSS	Resolver
P1 Marker Mode (03.031)	✓							
P1 Rotary Turns Bits (03.033)		●	●	●	✓	✓	●	
P1 Rotary Lines Per Revolution (03.034)	✓	●	●		✓			
P1 Comms Bits (03.035)		●	●	●	✓	✓	●	
P1 Supply Voltage (03.036)*	✓	✓	✓	✓	✓	✓	✓	
P1 Comms Baud Rate (03.037)			✓	✓	✓	✓	✓	
P1 Device Type (03.038)	✓	✓	✓	✓	✓	✓	✓	✓
P1 Auto-configuration Select (03.041)		✓	✓	✓			✓	
P1 SSI Binary Mode (03.048)					✓	✓		
P1 Resolver Poles (03.065)								✓
P1 Resolver Excitation (03.066)								✓

✓ Information required to be entered by the user.

● Parameter can be set-up automatically by the drive through auto-configuration parameter. Must be set by the user if auto-configuration is disabled (i.e. Pr **03.041** = Disabled (0)).

\* Pr **03.036**: If the output voltage from the encoder is >5 V, then termination resistors must be disabled by setting Pr **03.039** to 0.

Table 6-3 shows a summary of the parameters required to set-up each feedback device. More detailed information follows.

## 6.4.2 P1 position interface: Detailed feedback device commissioning / start-up information

### Standard quadrature encoder with or without commutation signals (A, B, Z or A, B, Z, U, V, W), or Sincos encoder with or without UVW commutation signals

<i>Device Type (03.038)</i>	<b>AB (0)</b> for a quadrature encoder without commutation signals * <b>AB Servo (3)</b> for a quadrature encoder with commutation signals <b>SC (6)</b> for a Sincos encoder without commutation signals * <b>SC Servo (12)</b> for a Sincos encoder with commutation signals																													
<i>Supply Voltage (03.036)</i>	<b>5 V (0), 8 V (1) or 15 V (2)</b> <b>NOTE</b> If output voltage from the encoder is >5 V, then the termination resistors must be disabled. Set Pr <b>03.039</b> to 0																													
<i>Rotary Line Per Revolution (03.034)</i>	Set to the number of lines or sine waves per revolution of the encoder.																													
<i>Termination Select (03.039)</i> (AB or AB Servo only)	<b>0</b> = A, B, Z termination resistors disabled <b>1</b> = A, B termination resistors enabled and Z termination resistors disabled <b>2</b> = A, B, Z termination resistors enabled																													
<i>Marker Mode (03.031)</i>	<table border="1"> <thead> <tr> <th colspan="4">Bit</th> <th rowspan="2">Description</th> </tr> <tr> <th>3</th> <th>2</th> <th>1</th> <th>0</th> </tr> </thead> <tbody> <tr> <td>x</td> <td>x</td> <td>x</td> <td>1</td> <td>No action is taken unless marker flag is zero before marker event occurs</td> </tr> <tr> <td>x</td> <td>x</td> <td>1</td> <td>x</td> <td>Pr <b>03.028</b> and Pr <b>03.058</b> are set to zero</td> </tr> <tr> <td>x</td> <td>1</td> <td>x</td> <td>x</td> <td>Pr <b>03.028</b>, Pr <b>03.029</b>, Pr <b>03.030</b> and the related part of Pr <b>03.058</b> are not reset. Pr <b>03.058</b> is transferred to Pr <b>03.059</b> and Pr <b>03.032</b> is set to 1.</td> </tr> <tr> <td>1</td> <td>x</td> <td>x</td> <td>x</td> <td>Undefined state region range is reduced from -30 mV to 30 mV. The marker pulse is only recognized if the pulse is 10 μs wide.</td> </tr> </tbody> </table>	Bit				Description	3	2	1	0	x	x	x	1	No action is taken unless marker flag is zero before marker event occurs	x	x	1	x	Pr <b>03.028</b> and Pr <b>03.058</b> are set to zero	x	1	x	x	Pr <b>03.028</b> , Pr <b>03.029</b> , Pr <b>03.030</b> and the related part of Pr <b>03.058</b> are not reset. Pr <b>03.058</b> is transferred to Pr <b>03.059</b> and Pr <b>03.032</b> is set to 1.	1	x	x	x	Undefined state region range is reduced from -30 mV to 30 mV. The marker pulse is only recognized if the pulse is 10 μs wide.
Bit				Description																										
3	2	1	0																											
x	x	x	1	No action is taken unless marker flag is zero before marker event occurs																										
x	x	1	x	Pr <b>03.028</b> and Pr <b>03.058</b> are set to zero																										
x	1	x	x	Pr <b>03.028</b> , Pr <b>03.029</b> , Pr <b>03.030</b> and the related part of Pr <b>03.058</b> are not reset. Pr <b>03.058</b> is transferred to Pr <b>03.059</b> and Pr <b>03.032</b> is set to 1.																										
1	x	x	x	Undefined state region range is reduced from -30 mV to 30 mV. The marker pulse is only recognized if the pulse is 10 μs wide.																										
<i>Error Detection Level (03.040)</i>	<table border="1"> <thead> <tr> <th colspan="4">Bit</th> <th rowspan="2">Description</th> </tr> <tr> <th>3</th> <th>2</th> <th>1</th> <th>0</th> </tr> </thead> <tbody> <tr> <td>x</td> <td>x</td> <td>x</td> <td>1</td> <td>Enable wire break detection</td> </tr> <tr> <td>1</td> <td>x</td> <td>x</td> <td>x</td> <td>Disable trips <i>Encoder 1 to Encoder 7</i></td> </tr> </tbody> </table>	Bit				Description	3	2	1	0	x	x	x	1	Enable wire break detection	1	x	x	x	Disable trips <i>Encoder 1 to Encoder 7</i>										
Bit				Description																										
3	2	1	0																											
x	x	x	1	Enable wire break detection																										
1	x	x	x	Disable trips <i>Encoder 1 to Encoder 7</i>																										

\* These settings should only be used in RFC-A mode. If used in RFC-S mode a phase offset test must be performed after every power up.

### Incremental encoder with Frequency and Direction (F and D) or Forward and Reverse (CW and CCW) signals with or without commutation signals.

<i>Device Type (03.038)</i>	<b>FD (1)</b> for frequency and direction signals without commutation signals* <b>FR (3)</b> for forward and reverse signals without commutation signals* <b>FD Servo (4)</b> for frequency and direction signals with commutation signals <b>FR Servo (5)</b> for forward and reverse signals with commutation signals																													
<i>Supply Voltage (03.036)</i>	<b>5 V (0), 8 V (1) or 15 V (2)</b> <b>NOTE</b> If output voltage from the encoder is >5 V, then the termination resistors must be disabled. Set Pr <b>03.039</b> to 0																													
<i>Rotary Line Per Revolution (03.034)</i>	Set to the number of pulses per revolution of the encoder divided by 2.																													
<i>Termination Select (03.039)</i>	<b>0</b> = F or CW, D or CCW, Z termination resistors disabled <b>1</b> = F or CW, D or CCW termination resistors enabled and Z termination resistors disabled <b>2</b> = For CW, D or CCW, Z termination resistors enabled																													
<i>Marker Mode (03.031)</i>	<table border="1"> <thead> <tr> <th colspan="4">Bit</th> <th rowspan="2">Description</th> </tr> <tr> <th>3</th> <th>2</th> <th>1</th> <th>0</th> </tr> </thead> <tbody> <tr> <td>x</td> <td>x</td> <td>x</td> <td>1</td> <td>No action is taken unless marker flag is zero before marker event occurs</td> </tr> <tr> <td>x</td> <td>x</td> <td>1</td> <td>x</td> <td>Pr <b>03.028</b> and Pr <b>03.058</b> are set to zero</td> </tr> <tr> <td>x</td> <td>1</td> <td>x</td> <td>x</td> <td>Pr <b>03.028</b>, Pr <b>03.029</b>, Pr <b>03.030</b> and the related part of Pr <b>03.058</b> are not reset. Pr <b>03.058</b> is transferred to Pr <b>03.059</b> and Pr <b>03.032</b> is set to 1.</td> </tr> <tr> <td>1</td> <td>x</td> <td>x</td> <td>x</td> <td>Undefined state region range is reduced from -30 mV to 30 mV. The marker pulse is only recognized if the pulse is 10 μs wide.</td> </tr> </tbody> </table>	Bit				Description	3	2	1	0	x	x	x	1	No action is taken unless marker flag is zero before marker event occurs	x	x	1	x	Pr <b>03.028</b> and Pr <b>03.058</b> are set to zero	x	1	x	x	Pr <b>03.028</b> , Pr <b>03.029</b> , Pr <b>03.030</b> and the related part of Pr <b>03.058</b> are not reset. Pr <b>03.058</b> is transferred to Pr <b>03.059</b> and Pr <b>03.032</b> is set to 1.	1	x	x	x	Undefined state region range is reduced from -30 mV to 30 mV. The marker pulse is only recognized if the pulse is 10 μs wide.
Bit				Description																										
3	2	1	0																											
x	x	x	1	No action is taken unless marker flag is zero before marker event occurs																										
x	x	1	x	Pr <b>03.028</b> and Pr <b>03.058</b> are set to zero																										
x	1	x	x	Pr <b>03.028</b> , Pr <b>03.029</b> , Pr <b>03.030</b> and the related part of Pr <b>03.058</b> are not reset. Pr <b>03.058</b> is transferred to Pr <b>03.059</b> and Pr <b>03.032</b> is set to 1.																										
1	x	x	x	Undefined state region range is reduced from -30 mV to 30 mV. The marker pulse is only recognized if the pulse is 10 μs wide.																										
<i>Error Detection Level (03.040)</i>	<table border="1"> <thead> <tr> <th colspan="4">Bit</th> <th rowspan="2">Description</th> </tr> <tr> <th>3</th> <th>2</th> <th>1</th> <th>0</th> </tr> </thead> <tbody> <tr> <td>x</td> <td>x</td> <td>x</td> <td>1</td> <td>Enable wire break detection</td> </tr> <tr> <td>1</td> <td>x</td> <td>x</td> <td>x</td> <td>Disable trips <i>Encoder 1 to Encoder 7</i></td> </tr> </tbody> </table>	Bit				Description	3	2	1	0	x	x	x	1	Enable wire break detection	1	x	x	x	Disable trips <i>Encoder 1 to Encoder 7</i>										
Bit				Description																										
3	2	1	0																											
x	x	x	1	Enable wire break detection																										
1	x	x	x	Disable trips <i>Encoder 1 to Encoder 7</i>																										

\* These settings should only be used in RFC-A mode. If used in RFC-S mode a phase offset test must be performed after every power up.

**Absolute Sincos encoder with Hiperface or EnDat serial communication, or Absolute EnDat communication only encoder or BiSS encoder**

<i>Device Type (03.038)</i>	<b>SC Hiperface (7)</b> for a Sincos encoder with Hiperface serial communications <b>EnDat (8)</b> for an EnDat communications only encoder <b>SC EnDat (9)</b> for a Sincos encoder with EnDat serial communications <b>BiSS (13)</b> for a BiSS communication only encoder																								
<i>Supply Voltage (03.036)</i>	<b>5 V (0), 8 V (1) or 15 V (2)</b>																								
<i>Auto-configuration Select (03.041)</i>	Auto-configuration is enabled at default and automatically sets up the following parameters. <i>Rotary Turns Bits (03.033)</i> <i>Rotary Lines Per Revolutions (03.034)</i> <i>Comms Bits (03.035)</i> These parameters can be entered manually when Pr 03.041 is set to Disabled (0).																								
<i>Comms Baud Rate (03.037)</i>	100 k, 200 k, 300 k, 400 k, 500 k, 1 M, 1.5 M, 2 M, 4 M																								
<i>Error Detection Level (03.040)</i>	<table border="1"> <thead> <tr> <th colspan="4">Bit</th> <th rowspan="2">Description</th> </tr> <tr> <th>3</th> <th>2</th> <th>1</th> <th>0</th> </tr> </thead> <tbody> <tr> <td>x</td> <td>x</td> <td>x</td> <td>1</td> <td>Enable wire break detection</td> </tr> <tr> <td>x</td> <td>x</td> <td>1</td> <td>x</td> <td>Enable phase error detection</td> </tr> <tr> <td>1</td> <td>x</td> <td>x</td> <td>x</td> <td>Disable trips <i>Encoder 1 to Encoder 7</i></td> </tr> </tbody> </table> <p>So for example, to enable the wire break and phase error detection, set Pr <b>03.040</b> to 0011.</p>	Bit				Description	3	2	1	0	x	x	x	1	Enable wire break detection	x	x	1	x	Enable phase error detection	1	x	x	x	Disable trips <i>Encoder 1 to Encoder 7</i>
Bit				Description																					
3	2	1	0																						
x	x	x	1	Enable wire break detection																					
x	x	1	x	Enable phase error detection																					
1	x	x	x	Disable trips <i>Encoder 1 to Encoder 7</i>																					

**Absolute SSI communications only encoder, or Absolute Sincos encoder with SSI communications**

<i>Device Type (03.038)</i>	<b>SSI (10)</b> for a SSI communications only encoder <b>SC SSI (11)</b> for a Sincos encoder with SSI serial communications																													
<i>Supply Voltage (03.036)</i>	<b>5 V (0), 8 V (1) or 15 V (2)</b>																													
<i>Rotary Line Per Revolution (03.034)</i>	Set the number of sine waves per revolution of the encoder																													
<i>SSI Binary Mode (03.048)</i>	Off = Gray Code On = Binary Mode																													
<i>Rotary Turns Bits (03.033)</i>	Set to the number of turns bits for the encoder (this is normally 12 bits for a SSI encoder)																													
<i>Comms Bits (03.035)</i>	Total number of bits of position information (this is usually 25 bits for a SSI encoder)																													
<i>Comms Baud Rate (03.037)</i>	100 k, 200 k, 300 k, 400 k, 500 k, 1 M, 1.5 M, 2 M, 4 M																													
<i>Error Detection Level (03.040)</i>	<table border="1"> <thead> <tr> <th colspan="4">Bit</th> <th rowspan="2">Description</th> </tr> <tr> <th>3</th> <th>2</th> <th>1</th> <th>0</th> </tr> </thead> <tbody> <tr> <td>x</td> <td>x</td> <td>x</td> <td>1</td> <td>Enable wire break detection</td> </tr> <tr> <td>x</td> <td>x</td> <td>1</td> <td>x</td> <td>Enable phase error detection</td> </tr> <tr> <td>x</td> <td>1</td> <td>x</td> <td>x</td> <td>Enable SSI power supply alarm bit monitor</td> </tr> <tr> <td>1</td> <td>x</td> <td>x</td> <td>x</td> <td>Disable trips <i>Encoder 1 to Encoder 7</i></td> </tr> </tbody> </table> <p>So for example, to enable the wire break and phase error detection, set Pr <b>03.040</b> to 0011.</p>	Bit				Description	3	2	1	0	x	x	x	1	Enable wire break detection	x	x	1	x	Enable phase error detection	x	1	x	x	Enable SSI power supply alarm bit monitor	1	x	x	x	Disable trips <i>Encoder 1 to Encoder 7</i>
Bit				Description																										
3	2	1	0																											
x	x	x	1	Enable wire break detection																										
x	x	1	x	Enable phase error detection																										
x	1	x	x	Enable SSI power supply alarm bit monitor																										
1	x	x	x	Disable trips <i>Encoder 1 to Encoder 7</i>																										

**UVW commutation signal only encoders\***

<i>Device Type (03.038)</i>	Commutation Only (16) for a quadrature encoder with commutation signals*
<i>Supply Voltage (03.036)</i>	<b>5 V (0), 8 V (1) or 15 V (2)</b>
<i>Error Detection Level (03.040)</i>	Set to zero to disable wire break detection

\* This feedback device provides very low resolution feedback and should not be used for applications requiring a high level of performance. Due to the low resolution of UVW communication only encoders, it is recommended that the *P1 Feedback Filter (03.042)* is set to its maximum value. A value of 1 ms to 2 ms may also be required in the *Current Demand Filter (04.012)* and it is also recommended that the speed loop gains are set to a low value to obtain stable operation.

## Resolver

<i>Device Type (03.038)</i>	Resolver (14)																			
<i>Resolver Poles (03.065)</i>	Set number of Resolver poles 2 poles, 4 poles, 6 poles, 8 poles																			
<i>Resolver Excitation (03.066)</i>	Set Resolver excitation voltage and frequency <b>6 V</b> Auto (0), <b>4 V</b> Auto (1), <b>6 V</b> 6 kHz (2), <b>4 V</b> 6 kHz (3), <b>6 V</b> 8 kHz (4), <b>4 V</b> 8 kHz (5)																			
<i>Error Detection Level (03.040)</i>	<table border="1"> <thead> <tr> <th colspan="4">Bit</th> <th rowspan="2">Description</th> </tr> <tr> <th>3</th> <th>2</th> <th>1</th> <th>0</th> </tr> </thead> <tbody> <tr> <td>x</td> <td>x</td> <td>x</td> <td>1</td> <td>Enable wire break detection</td> </tr> <tr> <td>1</td> <td>x</td> <td>x</td> <td>x</td> <td>Disable trips <i>Encoder 1 to Encoder 7</i></td> </tr> </tbody> </table> <p>So for example, to enable the wire break error detection, set Pr <b>03.040</b> to 0001.</p>	Bit				Description	3	2	1	0	x	x	x	1	Enable wire break detection	1	x	x	x	Disable trips <i>Encoder 1 to Encoder 7</i>
Bit				Description																
3	2	1	0																	
x	x	x	1	Enable wire break detection																
1	x	x	x	Disable trips <i>Encoder 1 to Encoder 7</i>																

### 6.4.3 P2 position interface

This section shows the parameter settings which must be made to use each of the compatible feedback device types with the P2 position interface on the drive. For more information on the parameters listed here please refer to the *Parameter Reference Guide*. If the position feedback device connected to the P2 position interface is required to be used for motor control feedback then Pr **03.026** will need to be set to P2 Drive (1).

**Table 6-4 Parameters required for feedback device set-up on the P2 position interface**

Parameter	AB, FD, FR	EnDat	SSI	BiSS
<i>P2 Marker Mode (03.131)</i>	✓			
<i>P2 Rotary Turns Bits (03.133)</i>		●	●	●
<i>P2 Rotary Lines Per Revolution (03.134)</i>	✓			
<i>P2 Comms Bits (03.135)</i>		●	●	●
<i>P2 Comms Baud Rate (03.137)</i>		✓	✓	✓
<i>P2 Device Type (03.138)</i>	✓	✓	✓	✓
<i>P2 Auto-configuration Select (03.141)</i>		✓		✓

✓ Information required to be entered by the user.

- Parameter can be set-up automatically by the drive through auto-configuration. Parameter must be set by the user if auto-configuration is disabled (i.e. Pr **03.041** = Disabled (0)).

The P2 position interface does not have its own independent power supply output. Therefore, any position feedback device connected to the P2 position interface must either share the P1 power supply output on pin 13 of the 15-way D-type, or be supplied from an external source.

#### NOTE

The termination resistors are always enabled on the P2 position interface. Wire break detection is not available when using AB, FD or FR position feedback device types on the P2 position interface.

Table 6-4 shows a summary of the parameters required to set-up each feedback device. More detailed information follows.

## Standard quadrature encoder (A, B, Z)

<i>Device Type (03.138)</i>	<b>AB</b> (1) for a quadrature encoder																													
<i>Rotary Line Per Revolution (03.134)</i>	Set to the number of lines per revolution of the encoder																													
<i>Marker Mode (03.131)</i>	<table border="1"> <thead> <tr> <th colspan="4">Bit</th> <th rowspan="2">Description</th> </tr> <tr> <th>3</th> <th>2</th> <th>1</th> <th>0</th> </tr> </thead> <tbody> <tr> <td>x</td> <td>x</td> <td>x</td> <td>1</td> <td>No action is taken unless marker flag is zero before marker event occurs</td> </tr> <tr> <td>x</td> <td>x</td> <td>1</td> <td>x</td> <td>Pr <b>03.128</b> and Pr <b>03.158</b> are set to zero</td> </tr> <tr> <td>x</td> <td>1</td> <td>x</td> <td>x</td> <td>Pr <b>03.128</b>, Pr <b>03.129</b>, Pr <b>03.130</b> and the related part of Pr <b>03.158</b> are not reset. Pr <b>03.158</b> is transferred to Pr <b>03.159</b> and Pr <b>03.132</b> is set to 1.</td> </tr> <tr> <td>1</td> <td>x</td> <td>x</td> <td>x</td> <td>Undefined state region range is reduced from -30 mV to 30 mV. The marker pulse is only recognized if the pulse is 10 μs wide.</td> </tr> </tbody> </table>	Bit				Description	3	2	1	0	x	x	x	1	No action is taken unless marker flag is zero before marker event occurs	x	x	1	x	Pr <b>03.128</b> and Pr <b>03.158</b> are set to zero	x	1	x	x	Pr <b>03.128</b> , Pr <b>03.129</b> , Pr <b>03.130</b> and the related part of Pr <b>03.158</b> are not reset. Pr <b>03.158</b> is transferred to Pr <b>03.159</b> and Pr <b>03.132</b> is set to 1.	1	x	x	x	Undefined state region range is reduced from -30 mV to 30 mV. The marker pulse is only recognized if the pulse is 10 μs wide.
Bit				Description																										
3	2	1	0																											
x	x	x	1	No action is taken unless marker flag is zero before marker event occurs																										
x	x	1	x	Pr <b>03.128</b> and Pr <b>03.158</b> are set to zero																										
x	1	x	x	Pr <b>03.128</b> , Pr <b>03.129</b> , Pr <b>03.130</b> and the related part of Pr <b>03.158</b> are not reset. Pr <b>03.158</b> is transferred to Pr <b>03.159</b> and Pr <b>03.132</b> is set to 1.																										
1	x	x	x	Undefined state region range is reduced from -30 mV to 30 mV. The marker pulse is only recognized if the pulse is 10 μs wide.																										

### Incremental encoder with Frequency and Direction (F and D), or Forward and Reverse (CW and CCW) signals

<i>Device Type (03.138)</i>	<b>FD (2)</b> for frequency and direction signals without commutation signals <b>FR (3)</b> for forward and reverse signals without commutation signals																													
<i>Rotary Line Per Revolution (03.134)</i>	Set to the number of pulses per revolution of the encoder divided by 2																													
<i>Marker Mode (03.131)</i>	<table border="1"> <thead> <tr> <th colspan="4">Bit</th> <th rowspan="2">Description</th> </tr> <tr> <th>3</th> <th>2</th> <th>1</th> <th>0</th> </tr> </thead> <tbody> <tr> <td>x</td> <td>x</td> <td>x</td> <td>1</td> <td>No action is taken unless marker flag is zero before marker event occurs</td> </tr> <tr> <td>x</td> <td>x</td> <td>1</td> <td>x</td> <td>Pr <b>03.128</b> and Pr <b>03.158</b> are set to zero</td> </tr> <tr> <td>x</td> <td>1</td> <td>x</td> <td>x</td> <td>Pr <b>03.128</b>, Pr <b>03.129</b>, Pr <b>03.130</b> and the related part of Pr <b>03.158</b> are not reset. Pr <b>03.158</b> is transferred to Pr <b>03.159</b> and Pr <b>03.132</b> is set to 1.</td> </tr> <tr> <td>1</td> <td>x</td> <td>x</td> <td>x</td> <td>Undefined state region range is reduced from -30 mV to 30 mV. The marker pulse is only recognized if the pulse is 10 μs wide.</td> </tr> </tbody> </table>	Bit				Description	3	2	1	0	x	x	x	1	No action is taken unless marker flag is zero before marker event occurs	x	x	1	x	Pr <b>03.128</b> and Pr <b>03.158</b> are set to zero	x	1	x	x	Pr <b>03.128</b> , Pr <b>03.129</b> , Pr <b>03.130</b> and the related part of Pr <b>03.158</b> are not reset. Pr <b>03.158</b> is transferred to Pr <b>03.159</b> and Pr <b>03.132</b> is set to 1.	1	x	x	x	Undefined state region range is reduced from -30 mV to 30 mV. The marker pulse is only recognized if the pulse is 10 μs wide.
	Bit				Description																									
	3	2	1	0																										
	x	x	x	1	No action is taken unless marker flag is zero before marker event occurs																									
	x	x	1	x	Pr <b>03.128</b> and Pr <b>03.158</b> are set to zero																									
x	1	x	x	Pr <b>03.128</b> , Pr <b>03.129</b> , Pr <b>03.130</b> and the related part of Pr <b>03.158</b> are not reset. Pr <b>03.158</b> is transferred to Pr <b>03.159</b> and Pr <b>03.132</b> is set to 1.																										
1	x	x	x	Undefined state region range is reduced from -30 mV to 30 mV. The marker pulse is only recognized if the pulse is 10 μs wide.																										

### Absolute EnDat communication only encoder or BiSS encoder

<i>Device Type (03.138)</i>	<b>EnDat (4)</b> for an EnDat communications only encoder <b>BiSS (6)</b> for a BiSS communication only encoder														
<i>Auto-configuration Select (03.141)</i>	Auto-configuration is enabled at default and automatically sets up the following parameters: <i>Rotary Turns Bits (03.133)</i> <i>Comms Bits (03.135)</i> These parameters can be entered manually when Pr <b>03.141</b> is set to Disabled (0).														
<i>Comms Baud Rate (03.137)</i>	100 k, 200 k, 300 k, 400 k, 500 k, 1 M, 1.5 M, 2 M, 4 M														
<i>Error Detection Level (03.140)</i>	<table border="1"> <thead> <tr> <th colspan="4">Bit</th> <th rowspan="2">Description</th> </tr> <tr> <th>3</th> <th>2</th> <th>1</th> <th>0</th> </tr> </thead> <tbody> <tr> <td>1</td> <td>x</td> <td>x</td> <td>x</td> <td>Disable trips <i>Encoder 4 to Encoder 7</i></td> </tr> </tbody> </table>	Bit				Description	3	2	1	0	1	x	x	x	Disable trips <i>Encoder 4 to Encoder 7</i>
	Bit				Description										
3	2	1	0												
1	x	x	x	Disable trips <i>Encoder 4 to Encoder 7</i>											

### Absolute SSI communications only encoder

<i>Device Type (03.138)</i>	<b>SSI (5)</b> for a SSI communications only encoder																			
<i>SSI Binary Mode (03.148)</i>	<b>Off (0)</b> = Gray Code <b>On (1)</b> = Binary Mode																			
<i>Rotary Turns Bits (03.133)</i>	Set to the number of turns bits for the encoder (this is usually 12 bits for a multi-turn SSI encoder)																			
<i>Comms Bits (03.135)</i>	Total number of bits of position information for the encoder (this is usually 25 bits for a multi-turn SSI encoder)																			
<i>Comms Baud Rate (03.137)</i>	100 k, 200 k, 300 k, 400 k, 500 k, 1 M, 1.5 M, 2 M, 4 M																			
<i>Error Detection Level (03.140)</i>	<table border="1"> <thead> <tr> <th colspan="4">Bit</th> <th rowspan="2">Description</th> </tr> <tr> <th>3</th> <th>2</th> <th>1</th> <th>0</th> </tr> </thead> <tbody> <tr> <td>x</td> <td>1</td> <td>x</td> <td>x</td> <td><i>Enable SSI power supply alarm bit monitor</i></td> </tr> <tr> <td>1</td> <td>x</td> <td>x</td> <td>x</td> <td>Disable trips <i>Encoder 4 to Encoder 7</i></td> </tr> </tbody> </table>	Bit				Description	3	2	1	0	x	1	x	x	<i>Enable SSI power supply alarm bit monitor</i>	1	x	x	x	Disable trips <i>Encoder 4 to Encoder 7</i>
	Bit				Description															
	3	2	1	0																
x	1	x	x	<i>Enable SSI power supply alarm bit monitor</i>																
1	x	x	x	Disable trips <i>Encoder 4 to Encoder 7</i>																

## 6.5 Encoder Simulation Output Set-up

The drive supports three modes of encoder simulation output.

- Hardware mode - Incremental signals (AB, FD, FR)
- Software mode - Incremental signals (AB, FD, FR)
- Software mode - Absolute SSI data

The availability of the encoder simulation output on the 15-way D-type on the drive is dependent on the type of feedback device connected to the P1 position interface. See Table 3-8 on page 24 for more information on the availability of the encoder simulation output. The status of the encoder simulation output can be seen in *Encoder Simulation Status (03.086)* as follows:

- None (0) The encoder simulation output is not enabled or is not available
- Full (1) Full encoder simulation with marker output is available
- No Marker (2) Encoder simulation without marker output is available

This section shows the parameter settings which must be made to use the encoder simulation output on the drive. For more information on the parameters listed here please refer to the Parameter Reference Guide.

### 6.5.1 Hardware mode - Incremental signals (AB, FD, or FR)

Hardware mode provides incremental signals derived via hardware from the P1 position feedback interface on the drive, with negligible delay. The supported incremental output signals are AB, FD and FR. Hardware mode only produces an output when the input device connected to the P1 position interface is AB, FD, FR, SC, SC Hiperface, SC EnDat or SC SSI type devices. It should be noted that with a SINCOS source device the output is based on the zero crossings of the sine wave inputs and does not include interpolation.

Hardware mode set-up	
<i>Encoder Simulation Source (03.085)</i>	This parameter must be set to <b>03.029</b> to select the P1 position interface as the source.
<i>Encoder Simulation Mode (03.088)</i>	Set to a value of <b>Hardware (0)</b>
<i>Encoder Simulation Hardware Divider (03.089)</i>	This parameter defines the divider ratio between the device connected to the P1 position feedback interface and the output. <b>0</b> = 1/1 <b>1</b> = 1/2 <b>2</b> = 1/4 <b>3</b> = 1/8 <b>4</b> = 1/16 <b>5</b> = 1/32 <b>6</b> = 1/64 <b>7</b> = 1/128
<i>Encoder Simulation Hardware Marker Lock (03.090)</i>	<b>0</b> = The marker output is derived directly from the marker input <b>1</b> = The incremental output signals are adjusted on each marker event so that the A and B are high with an AB type output, or F is high with an FD or FR type output
<i>Encoder Simulation Output Mode(03.098)</i>	<b>AB/Gray (0)</b> for a AB quadrature output signals <b>FD/Binary (1)</b> for Frequency and Direction output signals <b>FR/Binary (2)</b> for Forward and Reverse output signals

### 6.5.2 Software mode - Incremental signals (AB, FD, or FR)

In software mode the encoder simulation output is derived via software from the selected source with a minimum delay of 250 μs which may be extended with *Encoder Simulation Sample Period (03.087)*. For incremental output signals, the resolution of the output can be defined by either selecting the required output lines per revolution or by an output ratio.

#### Lines per revolution

The output resolution of the encoder simulation output is defined by *Encoder Simulation Output Lines Per Revolution (03.092)*.

AB quadrature output signals, software mode setup – Lines per revolution	
<i>Encoder Simulation Source (03.085)</i>	Set to the parameter number of the position source Pr <b>03.029</b> to use the P1 position interface on the drive as the source. Pr <b>03.129</b> to use the P2 position interface on the drive as the source. This parameter can be set to any other valid position reference generated by the drive or an option module.
<i>Encoder Simulation Mode (03.088)</i>	Set to a value of <b>Lines Per Rev (1)</b>
<i>Encoder Simulation Output Lines Per Revolution (03.092)</i>	Set to the required output lines per revolution. The maximum output lines per revolution are 16384.
<i>Encoder Simulation Output Mode (03.098)</i>	<b>AB/Gray (0)</b> for a AB quadrature output signals

Frequency and Direction or Forward and Reverse output signals, software mode setup – Lines per revolution	
<i>Encoder Simulation Source (03.085)</i>	Set to the parameter number of the position source Pr <b>03.029</b> to use the P1 position interface on the drive as the source. Pr <b>03.129</b> to use the P2 position interface on the drive as the source. This parameter can be set to any other valid position reference generated by the drive or an option module.
<i>Encoder Simulation Mode (03.088)</i>	Set to a value of <b>Lines Per Rev (1)</b>
<i>Encoder Simulation Output Lines Per Revolution (03.092)</i>	Set to the required output pulse per revolution divided by 2. For example if 2000 pulses per revolution is required, set this parameter to 1000.
<i>Encoder Simulation Output Mode (03.098)</i>	<b>FD/Binary (1)</b> for Frequency and Direction output signals <b>FR/Binary (2)</b> for Forward and Reverse output signals

## Ratio

In ratio mode the resolution of the input source is based on a 16 bit position feedback device (i.e. equivalent to an AB quadrature encoder with a resolution of 16384 lines per revolution). The output resolution of the encoder simulation output is defined by the ratio of *Encoder Simulation Numerator* (03.093) and *Encoder Simulation Denominator* (03.094).

### AB quadrature output signals, software mode setup – Ratio Frequency and Direction or Forward and Reverse output signals, software mode setup

<i>Encoder Simulation Source</i> (03.085)	Set to the parameter number of the position source Pr <b>03.029</b> to use the P1 position interface on the drive as the source. Pr <b>03.129</b> to use the P2 position interface on the drive as the source. This parameter can be set to any other valid position reference generated by the drive or an option module.
<i>Encoder Simulation Mode</i> (03.088)	Set to a value of <b>Ratio (2)</b>
<i>Encoder Simulation Numerator</i> (03.093) and <i>Encoder Simulation Denominator</i> (03.094)	Set these two parameters to give the required output ratio.
<i>Encoder Simulation Output Mode</i> (03.098)	<b>AB/Gray</b> (0) for a AB quadrature output signals <b>FD/Binary</b> (1) for Frequency and Direction output signals <b>FR/Binary</b> (2) for Forward and Reverse output signals

## Software mode - Absolute SSI data

In software mode the encoder simulation output is derived via software from the selected source with a minimum delay of 250 μs which may be extended with *Encoder Simulation Sample Period* (03.087). In SSI output mode drive will simulate an SSI encoder, where the number of bits and the format of the position message can be adjusted.

### Absolute SSI data, software mode setup

<i>Encoder Simulation Source</i> (03.085)	Set to the parameter number of the position source Pr <b>03.029</b> to use the P1 position interface on the drive as the source. Pr <b>03.129</b> to use the P2 position interface on the drive as the source. This parameter can be set to any other valid position reference generated by the drive or an option module.
<i>Encoder Simulation Mode</i> (03.088)	Set to a value of <b>SSI (3)</b>
<i>Encoder Simulation SSI Turns Bits</i> (03.096)	Set to the number of bits representing the number of turns in the position message.
<i>Encoder Simulation SSI Comms Bits</i> (03.097)	Set to the number bits in the whole position message.
<i>Encoder Simulation Output Mode</i> (03.098)	<b>AB/Gray</b> (0) for position data in Gray code format <b>FD/Binary</b> (1) or <b>FR/Binary</b> (2) for position data in binary format

# 7 Optimization

This chapter takes the user through methods of optimizing the drive set-up and maximize the performance. The auto-tuning features of the drive simplify the optimization tasks.

## 7.1 Motor map parameters

### 7.1.1 Open loop motor control

#### Pr 00.046 {05.007} Rated Current

Defines the maximum continuous motor current

- The rated current parameter must be set to the maximum continuous current of the motor. (See section 7.2 *Maximum motor rated current* on page 86, for information about setting this parameter higher than the maximum Heavy Duty current rating). The motor rated current is used in the following:
  - Current limits (see section 7.3 *Current limits* on page 86, for more information)
  - Motor thermal overload protection (see section 7.4 *Motor thermal protection* on page 86, for more information)
  - Vector mode voltage control (see *Open Loop Control Mode* (00.007), later in this table)
  - Slip compensation (see *Enable Slip Compensation* (05.027), later in this table)
  - Dynamic V/F control

#### Pr 00.044 {05.009} Rated Voltage

Defines the voltage applied to the motor at rated frequency

#### Pr 00.047 {05.006} Rated Frequency

Defines the frequency at which rated voltage is applied

The *Rated Voltage* (00.044) and the *Rated Frequency* (00.047) are used to define the voltage to frequency characteristic applied to the motor (see *Open Loop Control Mode* (00.007), later in this table). The *Rated Frequency* (00.047) is also used in conjunction with the motor rated speed to calculate the rated slip for slip compensation (see *Rated Speed* (00.045), later in this table).

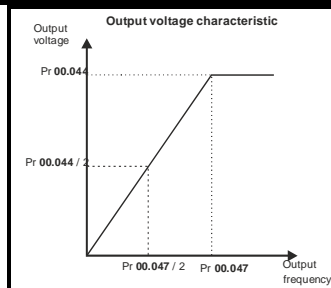

#### Pr 00.045 {05.008} Rated Speed

Defines the full load rated speed of the motor

#### Pr 00.042 {05.011} Number Of Motor Poles

Defines the number of motor poles

The motor rated speed and the number of poles are used with the motor rated frequency to calculate the rated slip of induction machines in Hz.

$$\text{Rated slip (Hz)} = \text{Motor rated frequency} - (\text{Number of pole pairs} \times [\text{Motor rated speed} / 60]) = 00.047 = \left( \frac{00.042}{2} \times \frac{00.045}{60} \right)$$

If Pr 00.045 is set to 0 or to synchronous speed, slip compensation is disabled. If slip compensation is required this parameter should be set to the nameplate value, which should give the correct rpm for a hot machine. Sometimes it will be necessary to adjust this when the drive is commissioned because the nameplate value may be inaccurate. Slip compensation will operate correctly both below base speed and within the field-weakening region. Slip compensation is normally used to correct for the motor speed to prevent speed variation with load. The rated load rpm can be set higher than synchronous speed to deliberately introduce speed droop. This can be useful to aid load sharing with mechanically coupled motors.

Pr 00.042 is also used in the calculation of the motor speed display by the drive for a given output frequency. When Pr 00.042 is set to 'Automatic', the number of motor poles is automatically calculated from the rated frequency Pr 00.047, and the motor rated speed Pr 00.045.

$$\text{Number of poles} = 120 \times (\text{Rated Frequency} (00.047) / \text{Rated Speed} (00.045)) \text{ rounded to the nearest even number.}$$

#### Pr 00.043 {05.010} Rated Power Factor

Defines the angle between the motor voltage and current

The power factor is the true power factor of the motor, i.e. the angle between the motor voltage and current. The power factor is used in conjunction with the *Rated Current* (00.046), to calculate the rated active current and magnetising current of the motor. The rated active current is used extensively to control the drive, and the magnetising current is used in vector mode stator resistance compensation. It is important that this parameter is set up correctly. The drive can measure the motor rated power factor by performing a rotating autotune (see *Autotune* (Pr 00.040), below).

### Pr 00.040 {05.012} Autotune

There are two autotune tests available in open loop mode, a stationary and a rotating test. A rotating autotune should be used whenever possible so the measured value of power factor of the motor is used by the drive.

- A stationary autotune can be used when the motor is loaded and it is not possible to remove the load from the motor shaft. The stationary test measures the *Stator Resistance* (05.017), *Transient Inductance* (05.024), *Voltage Offset At Zero Current* (05.058), *Maximum Voltage Offset* (05.059) and *Current At Maximum Voltage Offset* (05.060) which are required for good performance in vector control modes (see *Open Loop Control Mode* (00.007), later in this table). The stationary autotune does not measure the power factor of the motor so the value on the motor nameplate must be entered into Pr **00.043**. To perform a Stationary autotune, set Pr **00.040** to 1, and provide the drive with both an enable signal (terminal 31 on Unidrive HS70 / HS71 and terminal 11 & 13 on Unidrive HS72) and a run signal (terminal 26 or 27 on Unidrive HS70 / HS71 and terminal 7 or 8 on Unidrive HS72).
- A rotating autotune should only be used if the motor is unloaded. A rotating autotune first performs a stationary autotune, as above, then a rotating test is performed in which the motor is accelerated with currently selected ramps up to a frequency of *Rated Frequency* (05.006) x 2/3, and the frequency is maintained at that level for 4 seconds. *Stator Inductance* (05.025) is measured and this value is used in conjunction with other motor parameters to calculate *Rated Power Factor* (05.010). To perform a Rotating autotune, set Pr **00.040** to 2, and provide the drive with both an enable signal (terminal 31 on Unidrive HS70 / HS71 and terminal 11 & 13 on Unidrive HS72) and a run signal (terminal 26 or 27 on Unidrive HS70 / HS71 and terminal 7 or 8 on Unidrive HS72).

Following the completion of an autotune test the drive will go into the inhibit state. The drive must be placed into a controlled disable condition before the drive can be made to run at the required reference. The drive can be put in to a controlled disable condition by removing the SAFE TORQUE OFF signal from terminal 31 on *Unidrive HS70 / HS71* and terminal 11 & 13 on *Unidrive HS72*, setting the *Drive Enable* (06.015) to OFF (0) or disabling the drive via the *Control Word* (06.042) and *Control Word Enable* (06.043).

### Pr 00.007 {05.014} Open Loop Control Mode

There are several voltage modes available which fall into two categories, vector control and fixed boost.

#### Vector control

Vector control mode provides the motor with a linear voltage characteristic from 0 Hz to motor *Rated Frequency* (00.047), and then a constant voltage above motor rated frequency. When the drive operates between motor rated frequency/50 and motor rated frequency/4, full vector based stator resistance compensation is applied. When the drive operates between motor rated frequency/4 and motor rated frequency/2 the stator resistance compensation is gradually reduced to zero as the frequency increases. For the vector modes to operate correctly the *Rated Power Factor* (00.043), *Stator Resistance* (05.017) and *Voltage Offset At Zero Current* (05.058) are all required to be set up accurately. The drive can be made to measure these by performing an autotune (see Pr 00.040 *Autotune*). The drive can also be made to measure the stator resistance and voltage offset automatically every time the drive is enabled or the first time the drive is enabled after it is powered up, by selecting one of the vector control voltage modes.

(0) **Ur S** = The stator resistance and the voltage offset are measured and the parameters for the selected motor map are over-written each time the drive is made to run. This test can only be done with a stationary motor where the flux has decayed to zero. Therefore this mode should only be used if the motor is guaranteed to be stationary each time the drive is made to run. To prevent the test from being done before the flux has decayed there is a period of 1 second after the drive has been in the ready state during which the test is not done if the drive is made to run again. In this case, previously measured values are used. Ur S mode ensures that the drive compensates for any change in motor parameters due to changes in temperature. The new values of stator resistance and voltage offset are not automatically saved to the drive's EEPROM.(4)

(4) **Ur I** = The stator resistance and voltage offset are measured when the drive is first made to run after each power-up. This test can only be done with a stationary motor. Therefore this mode should only be used if the motor is guaranteed to be stationary the first time the drive is made to run after each power-up. The new values of stator resistance and voltage offset are not automatically saved to the drive's EEPROM.

(1) **Ur** = The stator resistance and voltage offset are not measured. The user can enter the motor and cabling resistance into the *Stator Resistance* (05.017). However this will not include resistance effects within the drive inverter. Therefore if this mode is to be used, it is best to use an autotune test initially to measure the stator resistance and voltage offset.

(3) **Ur\_Auto** = The stator resistance and voltage offset are measured once, the first time the drive is made to run. After the test has been completed successfully the *Open Loop Control Mode* (00.007) is changed to Ur mode. The *Stator Resistance* (05.017) and *Voltage Offset At Zero Current* (05.058) parameters are written to, and along with the *Open Loop Control Mode* (00.007), are saved in the drive's EEPROM. If the test fails, the voltage mode will stay set to Ur Auto and the test will be repeated next time the drive is made to run.

#### Fixed boost

Neither the stator resistance nor the voltage offset are used in the control of the motor, instead a fixed characteristic with low frequency voltage boost as defined by Pr **00.008**, is used. Fixed boost mode should be used when the drive is controlling multiple motors. There are two settings of fixed boost available:

(2) **Fixed** = This mode provides the motor with a linear voltage characteristic from 0 Hz to *Rated Frequency* (00.047), and then a constant voltage above rated frequency.

(5) **Square** = This mode provides the motor with a square law voltage characteristic from 0 Hz to *Rated Frequency* (00.047), and then a constant voltage above rated frequency. This mode is suitable for variable torque applications like fans and pumps where the load is proportional to the square of the speed of the motor shaft. This mode should not be used if a high starting torque is required.

### Pr 00.007 {05.014} Open Loop Control Mode (cont)

#### Fixed boost

Neither the stator resistance nor the voltage offset are used in the control of the motor, instead a fixed characteristic with low frequency voltage boost as defined by parameter Pr 00.008, is used. Fixed boost mode should be used when the drive is controlling multiple motors. There are two settings of fixed boost available:

(2) **Fixed** = This mode provides the motor with a linear voltage characteristic from 0 Hz to *Rated Frequency* (00.047), and then a constant voltage above rated frequency.

(5) **Square** = This mode provides the motor with a square law voltage characteristic from 0 Hz to *Rated Frequency* (00.047), and then a constant voltage above rated frequency. This mode is suitable for variable torque applications like fans and pumps where the load is proportional to the square of the speed of the motor shaft. This mode should not be used if a high starting torque is required.

For both these modes, at low frequencies (from 0Hz to  $\frac{1}{2} \times$  Pr 00.047) a voltage boost is applied defined by Pr 00.008 as shown below:

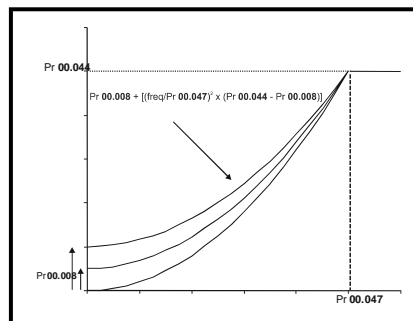
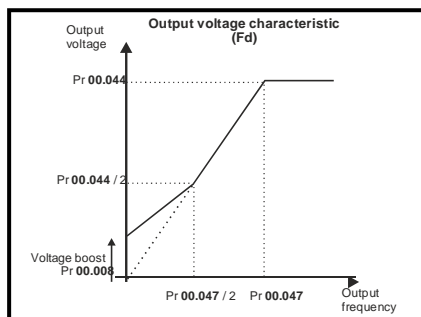

### Pr 05.027 Enable Slip Compensation

When a motor, being controlled in open loop mode, has load applied a characteristic of the motor is that the output speed droops in proportion to the load applied as shown:

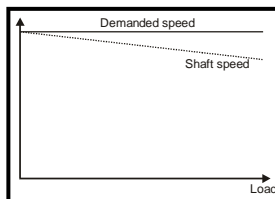

In order to prevent the speed droop shown above slip compensation should be enabled. To enable slip compensation Pr 05.027 must be set to a 1 (this is the default setting), and the motor rated speed must be entered in Pr 00.045 (Pr 05.008).

The motor rated speed parameter should be set to the synchronous speed of the motor minus the slip speed. This is normally displayed on the motor nameplate, i.e. for a typical 18.5 kW, 50 Hz, 4 pole motor, the motor rated speed would be approximately 1465 rpm. The synchronous speed for a 50 Hz, 4 pole motor is 1500 rpm, so therefore the slip speed would be 35 rpm. If the synchronous speed is entered in Pr 00.045, slip compensation will be disabled. If too small a value is entered in Pr 00.045, the motor will run faster than the demanded frequency. The synchronous speeds for 50 Hz motors with different numbers of poles are as follows:

2 pole = 3000 rpm, 4 pole = 1500 rpm, 6pole =1000 rpm, 8 pole = 750 rpm

## 7.1.2 RFC-A mode

### Induction motor with Position feedback

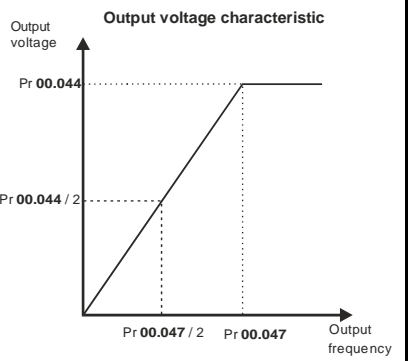
<b>Pr 00.046 {05.007} Motor Rated Current</b>	<b>Defines the maximum motor continuous current</b>
<p>The motor rated current parameter must be set to the maximum continuous current of the motor. (See section 7.2 <i>Maximum motor rated current</i> on page 86, for information about setting this parameter higher than the maximum Heavy Duty current rating.) The motor rated current is used in the following:</p> <ul style="list-style-type: none"> <li>• Current limits (see section 7.3 <i>Current limits</i> on page 86, for more information).</li> <li>• Motor thermal overload protection (see section 7.4 <i>Motor thermal protection</i> on page 86, for more information)</li> <li>• Vector control algorithm</li> </ul>	
<b>Pr 00.044 {05.009} Rated Voltage</b>	<b>Defines the voltage applied to the motor at rated frequency</b>
<b>Pr 00.047 {05.006} Rated Frequency</b>	<b>Defines the frequency at which rated voltage is applied</b>
<p>The <i>Rated Voltage</i> (00.044) and the <i>Rated Frequency</i> (00.047) are used to define the voltage to frequency characteristic applied to the motor (see <i>Open Loop Control Mode</i> (00.007), later in this table). The motor rated frequency is also used in conjunction with the motor rated speed to calculate the rated slip for slip compensation (see motor <i>Rated Speed</i> (00.045), later in this table).</p>	 <p>The graph, titled "Output voltage characteristic", plots Output voltage on the vertical axis against Output frequency on the horizontal axis. The curve starts at the origin (0,0) and rises linearly. A dashed line from the point (Pr 00.047 / 2, Pr 00.044 / 2) on the curve meets the axes. Another dashed line from the point (Pr 00.047, Pr 00.044) also meets the axes. The curve becomes horizontal at the frequency Pr 00.047, maintaining a constant output voltage of Pr 00.044.</p>
<b>Pr 00.045 {05.008} Rated Speed</b>	<b>Defines the full load rated speed of the motor</b>
<b>Pr 00.042 {05.011} Number Of Motor Poles</b>	<b>Defines the number of motor poles</b>
<p>The motor rated speed and motor rated frequency are used to determine the full load slip of the motor which is used by the vector control algorithm. Incorrect setting of this parameter has the following effects:</p> <ul style="list-style-type: none"> <li>• Reduced efficiency of motor operation</li> <li>• Reduction of maximum torque available from the motor</li> <li>• Reduced transient performance</li> <li>• Inaccurate control of absolute torque in torque control modes</li> </ul> <p>The nameplate value is normally the value for a hot motor; however, some adjustment may be required when the drive is commissioned if the nameplate value is inaccurate. Either a fixed value can be entered in this parameter or an optimization system may be used to automatically adjust this parameter (see <i>Motor Parameter Adaptive Control</i> (05.016), later in this table).</p> <p>When Pr <b>00.042</b> is set to 'Automatic', the number of motor poles is automatically calculated from the motor <i>Rated Frequency</i> (00.047), and the motor <i>Rated Speed</i> (00.045).</p> <p>Number of poles = <math>120 \times (\text{Motor Rated Frequency (00.047)} / \text{Motor Rated Speed (00.045)})</math> rounded to the nearest even number.</p>	
<b>Pr 00.043 {5.10} Rated Power Factor</b>	<b>Defines the angle between the motor voltage and current</b>
<p>The power factor is the true power factor of the motor, i.e. the angle between the motor voltage and current. If the <i>Stator Inductance</i> (05.025) is set to zero then the power factor is used in conjunction with the motor <i>Rated Current</i> (00.046) and other motor parameters to calculate the rated active and magnetising currents of the motor, which are used in the vector control algorithm. If the stator inductance has a non-zero value this parameter is not used by the drive, but is continuously written with a calculated value of power factor. The stator inductance can be measured by the drive by performing a rotating autotune (see <i>Autotune</i> (Pr 00.040), later in this table).</p>	

### Pr 00.040 {05.012} Autotune

There are three autotune tests available in RFC-A mode, a stationary test, a rotating test and an inertia measurement test. A stationary autotune will give moderate performance whereas a rotating autotune will give improved performance as it measures the actual values of the motor parameters required by the drive. An inertia measurement test should be performed separately to a stationary or rotating autotune.

#### NOTE

It is highly recommended that a rotating autotune is performed (Pr 00.040 set to 2).

- A stationary autotune can be used when the motor is loaded and it is not possible to remove the load from the motor shaft. The stationary autotune measures the *Stator Resistance* (05.017) and *Transient Inductance* (05.024) of the motor. These are used to calculate the current loop gains, and at the end of the test the values in Pr 04.013 and Pr 04.014 are updated. A stationary autotune does not measure the power factor of the motor so the value on the motor nameplate must be entered into Pr 00.043. To perform a Stationary autotune, set Pr 00.040 to 1, and provide the drive with both an enable signal (terminal 31 on Unidrive HS70 / HS71 and terminal 11 & 13 on Unidrive HS72) and a run signal (terminal 26 or 27 on Unidrive HS70 / HS71 and terminal 7 or 8 on Unidrive HS72).
- A rotating autotune should only be used if the motor is unloaded. A rotating autotune first performs a stationary autotune, a rotating test is then performed which the motor is accelerated with currently selected ramps up to a frequency of *Rated Frequency* (05.006) x 2/3, and the frequency is maintained at the level for up to 40 s. During the rotating autotune the *Stator Inductance* (05.025), and the motor saturation breakpoints (Pr 05.029, Pr 05.030, Pr 06.062 and Pr 05.063) are modified by the drive. The power factor is also modified for user information only, but is not used after this point as the stator inductance is used in the vector control algorithm instead. To perform a Rotating autotune, set Pr 00.040 to 2, and provide the drive with both an enable signal (terminal 31 on Unidrive HS70 / HS71 and terminal 11 & 13 on Unidrive HS72) and a run signal (terminal 26 or 27 on Unidrive HS70 / HS71 and terminal 7 or 8 on Unidrive HS72).
- The inertia measurement test can measure the total inertia of the load and the motor. This is used to set the speed loop gains (see Speed loop gains) and to provide torque feed-forwards when required during acceleration. During the inertia measurement test motor is accelerated with the currently selected ramps up to a speed of *Rated Speed* (05.008) / 4, and this speed is maintained at this level for 60 seconds. The *Motor And Load Inertia* (03.018) and load compensation parameters (*Load Compensation Param 1* (04.031) to *Load Compensation Param 4* (04.034)) are measured. If the required speed is not achieved on the final attempt the test is aborted and an Autotune trip is initiated. To perform an Inertia measurement autotune, set Pr 00.040 to 3, and provide the drive with both an enable signal (on terminal 31 on *Unidrive HS70 / HS71* and terminal 11 & 13 on *Unidrive HS72*) and a run signal (terminal 26 or 27 on *Unidrive HS70 / HS71* and terminal 7 or 8 on Unidrive HS72). Following the completion of an autotune test the drive will go into the inhibit state. The drive must be placed into a controlled disable condition before the drive can be made to run at the required reference. The drive can be put in to a controlled disable condition by removing the SAFE TORQUE OFF signal from terminal 31 on *Unidrive HS70 / HS71* and terminal 11 & 13 on *Unidrive HS72*, setting the *Drive Enable* (06.015) to OFF (0) or disabling the drive via the control word (Pr 06.042 & Pr 06.043).

### Pr 05.016 Motor Parameter Adaptive Control

The motor *Rated Speed* (00.045) in conjunction with the motor *Rated Frequency* (00.047) defines the full load slip of the motor. The slip is used in the motor model for RFC-A control. The full load slip of the motor varies with rotor resistance which can vary significantly with motor temperature. When Pr 05.016 is set to 1 or 2 the drive can automatically sense if the value of slip defined by Pr 00.047 and Pr 00.045 has been set incorrectly or if it has varied with motor temperature. If the value is incorrect Pr 00.045 is automatically adjusted. Pr 00.045 is not saved at power-down, and so when the drive is powered-down and up again it will return to the last saved value. If the new value is required at the next power-up it must be saved by the user.

The adaptive control system is only enabled when the  $|Output Frequency (05.001)|$  is above  $Rated Frequency (05.006) / 8$ , and the  $|Percentage Load (04.020)|$  is greater than 60 %. The adaptive control system is disabled again if the  $|Percentage Load (04.020)|$  falls below 50 %. For best optimization results the correct values of *Stator Resistance* (05.017), *Transient Inductance* (05.024), *Stator Inductance* (05.025), *Saturation Breakpoint 1* (05.029), *Saturation Breakpoint 2* (05.062), *Saturation Breakpoint 3* (05.030) and *Saturation Breakpoint 4* (05.063) should be used. If *Motor Parameter Adaptive Control* (05.016) = 1 the gain of the adaptive control system is low and hence the rate at which it converges is slow. If *Motor Parameter Adaptive Control* (05.016) = 2 the gain is increased by a factor of 16 and the convergence rate is increased.

### Pr 00.038 {04.013} / Pr 00.039 {04.014} Current Loop Gains

The current loop gains proportional (Kp) and integral (Ki) gains control the response of the current loop to a change in current (torque) demand. The default values give satisfactory operation with most motors. However, for optimal performance in dynamic applications it may be necessary to change the gains to improve the performance. The *Current Controller Kp Gain* (04.013) is the most critical value in controlling the performance. The values for the current loop gains can be calculated by performing a stationary or rotating autotune (see *Autotune* Pr 00.040, earlier in this table) the drive measures the *Stator Resistance* (05.017) and *Transient Inductance* (05.024) of the motor and calculates the current loop gains.

This will give a step response with minimum overshoot after a step change of current reference. The proportional gain can be increased by a factor of 1.5 giving a similar increase in bandwidth; however, this gives a step response with approximately 12.5 % overshoot. The equation for the integral gain gives a conservative value. In some applications where it is necessary for the reference frame used by the drive to dynamically follow the flux very closely (i.e. high speed Sensorless RFC-A induction motor applications) the integral gain may need to have a significantly higher value.

## Speed Loop Gains

(Pr 00.007 {03.010}, Pr 00.008 {03.011}, Pr 00.009 {03.012})

The speed loop gains control the response of the speed controller to a change in speed demand. The speed controller includes proportional (Kp) and integral (Ki) feed forward terms, and a differential (Kd) feedback term. The drive holds two sets of these gains and either set may be selected for use by the speed controller with Pr 03.016. If Pr 03.016 = 0, gains Kp1, Ki1 and Kd1 (Pr 00.007 to Pr 00.009) are used, and if Pr 03.016 = 1, gains Kp2, Ki2 and Kd2 (Pr 03.013 to Pr 03.015) are used. Pr 03.016 may be changed when the drive is enabled or disabled. If the load is predominantly a constant inertia and constant torque, the drive can calculate the required Kp and Ki gains to give a required compliance angle or bandwidth dependant on the setting of Pr 03.017.

### Speed Controller Proportional Gain (Kp), Pr 00.007 {03.010} and Pr 03.013

If the proportional gain has a value and the integral gain is set to zero the controller will only have a proportional term, and there must be a speed error to produce a torque reference. Therefore as the motor load increases there will be a difference between the reference and actual speeds. This effect, called regulation, depends on the level of the proportional gain, the higher the gain the smaller the speed error for a given load. If the proportional gain is too high either the acoustic noise produced by speed feedback quantization becomes unacceptable, or the stability limit is reached.

### Speed Controller Integral Gain (Ki), Pr 00.008 {03.011} and Pr 03.014

The integral gain is provided to prevent speed regulation. The error is accumulated over a period of time and used to produce the necessary torque demand without any speed error. Increasing the integral gain reduces the time taken for the speed to reach the correct level and increases the stiffness of the system, i.e. it reduces the positional displacement produced by applying a load torque to the motor. Unfortunately increasing the integral gain also reduces the system damping giving overshoot after a transient. For a given integral gain the damping can be improved by increasing the proportional gain. A compromise must be reached where the system response, stiffness and damping are all adequate for the application. For RFC-A Sensorless mode, it is unlikely that the integral gain can be increased much above 0.50.

### Differential Gain (Kd), Pr 00.009 {03.012} and Pr 03.015

The differential gain is provided in the feedback of the speed controller to give additional damping. The differential term is implemented in a way that does not introduce excessive noise normally associated with this type of function. Increasing the differential term reduces the overshoot produced by under-damping, however, for most applications the proportional and integral gains alone are sufficient.

There are three methods of tuning the speed loop gains dependant on the setting of Pr 03.017:

- Pr 03.017 = 0, User set-up.  
This involves the connecting of an oscilloscope to analog output 1 to monitor the speed feedback.  
Give the drive a step change in speed reference and monitor the response of the drive on the oscilloscope.  
The proportional gain (Kp) should be set up initially. The value should be increased up to the point where the speed overshoots and then reduced slightly.  
The integral gain (Ki) should then be increased up to the point where the speed becomes unstable and then reduced slightly.  
It may now be possible to increase the proportional gain to a higher value and the process should be repeated until the system response matches the ideal response as shown.  
The diagram shows the effect of incorrect P and I gain settings as well as the ideal response.
- Pr 03.017 = 1, Bandwidth set-up  
If bandwidth based set-up is required, the drive can calculate Kp and Ki if the following parameters are set up correctly:  
Pr 03.020 - Required bandwidth,  
Pr 03.021 - Required damping factor,  
Pr 03.018 - Motor and load inertia.  
The drive can be made to measure the motor and load inertia by performing an inertia measurement autotune (see Autotune Pr 00.040, earlier in this table).
- Pr 03.017 = 2, Compliance angle set-up  
If compliance angle based set-up is required, the drive can calculate Kp and Ki if the following parameters are set up correctly:  
Pr 03.019 - Required compliance angle,  
Pr 03.021 - Required damping factor,  
Pr 03.018 - Motor and load inertia The drive can be made to measure the motor and load inertia by performing an inertia measurement autotune (see Autotune Pr 00.040, earlier in this table).
- Pr 03.017 = 3, Kp gains times 16  
If Speed Controller Set-up Method (03.017) = 3 the selected proportional gain used by the drive is multiplied by 16.

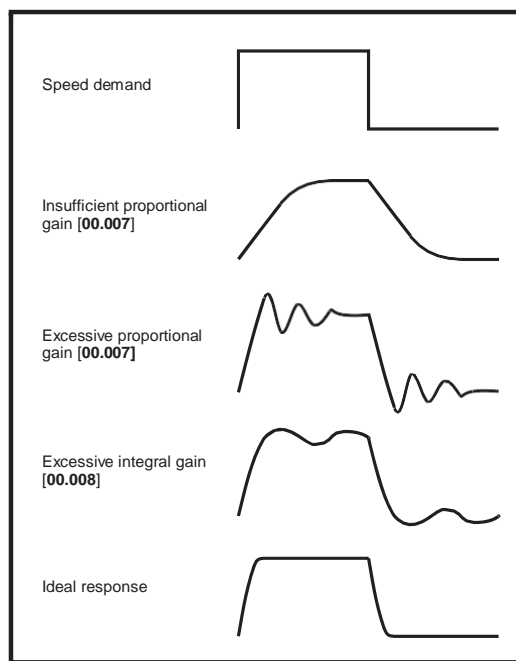

### 5. Pr 03.017 = 4 - 6

If Speed Controller Set-up Method (03.017) is set to a value from 4 to 6 the Speed Controller Proportional Gain Kp1 (03.010) and Speed Controller Integral Gain Ki1 (03.011) are automatically set up to give the bandwidths given in the table below and a damping factor of unity. These settings give low, standard or high performance.

Speed Controller Set-up Method (03.017)	Performance	Bandwidth
4	Low	5 Hz
5	Standard	25 Hz
6	High	100 Hz

### 7.1.3 RFC-S mode

#### Permanent magnet motor with Position feedback

##### Pr 00.046 {05.007} Rated Current

Defines the maximum motor continuous current

The motor rated current parameter must be set to the maximum continuous current of the motor. The motor rated current is used in the following:

- Current limits (see section 7.3 *Current limits* on page 86, for more information)
- Motor thermal overload protection (see section 7.4 *Motor thermal protection* on page 86, for more information)

##### Pr 00.042 {05.011} Number Of Motor Poles

Defines the number of motor poles

The number of motor poles parameter defines the number of electrical revolutions in one whole mechanical revolution of the motor. This parameter must be set correctly for the control algorithms to operate correctly. When Pr **00.042** is set to "Auto" the number of poles is 6.

##### Pr 00.040 {05.012} Autotune

There are four autotune tests available in RFC-S mode, a stationary autotune, a rotating autotune, an inertia measurement test and a locked rotor test to measure load dependent parameters.

###### • Stationary Autotune

The stationary autotune can be used when the motor is loaded and it is not possible uncouple the load from motor shaft. This test can be used to measure all the necessary parameters for basic control. During the stationary autotune, a test is performed to locate the flux axis of the motor. However this test may not be able to calculate such an accurate value for the *Position Feedback Phase Angle* (03.025) as compared to rotating autotune. A stationary test is performed to measure *Stator Resistance* (05.017), *Ld* (05.024), *Voltage Offset At Zero Current* (05.058), *Maximum Voltage Offset* (05.059), *Current At Maximum Voltage Offset* (05.060), *No Load Lq* (05.068) and *No Load Phase Offset* (05.070). If *Enable Stator Compensation* (05.049) = 1 then *Stator Base Temperature* (05.048) is made equal to *Stator Temperature* (05.046). The *Stator Resistance* (05.017) and the *Ld* (05.024) are then used to set up *Current controller Kp Gain* (04.013) and *Current Controller Ki Gain* (04.014). If sensorless mode is not selected then *Position Feedback Phase Angle* (03.025) is set up for the position from the position feedback interface selected with *Motor Control Feedback Select* (03.026). To perform a Stationary autotune, set Pr **00.040** to 1, and provide the drive with both an enable signal (terminal 31 on *Unidrive HS70 / HS71* and terminal 11 & 13 on *Unidrive HS72*) and a run signal (terminal 26 or 27 on *Unidrive HS70 / HS71* and terminal 7 or 8 on *Unidrive HS72*).

###### • Rotating Autotune

The rotating autotune must be performed on unloaded motor. This test can be used to measure all the necessary parameters for the basic control and parameters for cancelling the effects of the cogging torque.

During the rotating autotune, *Rated Current* (05.007) is applied and the motor is rotated by 2 electrical revolutions (i.e. up to 2 mechanical revolutions) in the required direction. If sensorless mode is not selected then the *Position Feedback Phase Angle* (03.025) is set-up for the position from the position feedback interface selected with *Motor Control Feedback Select* (03.026). A stationary test is then performed to measure *Stator Resistance* (05.017), *Ld* (05.024), *Voltage Offset At Zero Current* (05.058), *Maximum Voltage Offset* (05.059), *Current At Maximum Voltage Offset* (05.060) and *No Load Lq* (05.068). *Stator Resistance* (05.017) and *Ld* (05.024) are used to set up *Current Controller Kp Gain* (04.013) and *Current Controller Ki Gain* (04.014). This is only done once during the test, and so the user can make further adjustments to the current controller gains if required. After a delay of 5 s the motor is rotated through a further electrical revolution and *Cogging Data Parameter 1* (05.074) to *Cogging Data Parameter 8* (05.081) are measured. To perform a Rotating autotune, set Pr **00.040** to 2, and provide the drive with both an enable signal (terminal 31 on *Unidrive HS70 / HS71* and terminal 11 & 13 on *Unidrive HS72*) and a run signal (terminal 26 or 27 on *Unidrive HS70 / HS71* and terminal 7 or 8 on *Unidrive HS72*).

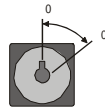

###### • Inertia measurement test

The inertia measurement test can measure the total inertia of the load and the motor. This is used to set the speed loop gains (see *Speed loop gains*) and to provide torque feed-forwards when required during acceleration. During the inertia measurement test motor is accelerated with the currently selected ramps up to a speed of *Rated Speed* (05.008) / 4, and this speed is maintained at this level for 60 seconds. The *Motor And Load Inertia* (03.018) and load compensation parameters (*Load Compensation Param 1* (04.031) to *Load Compensation Param 4* (04.034)) are measured. If the required speed is not achieved on the final attempt the test is aborted and an Autotune trip is initiated. To perform an Inertia measurement autotune, set Pr **00.040** to 3, and provide the drive with both an enable signal (on terminal 31 on *Unidrive HS70 / HS71* and terminal 11 & 13 on *Unidrive HS72*) and a run signal (terminal 26 or 27 on *Unidrive HS70 / HS71* and terminal 7 or 8 on *Unidrive HS72*). Following the completion of an autotune test the drive will go into the inhibit state. The drive must be placed into a controlled disable condition before the drive can be made to run at the required reference. The drive can be put in to a controlled disable condition by removing the SAFE TORQUE OFF signal from terminal 31 on *Unidrive HS70 / HS71* and terminal 11 & 13 on *Unidrive HS72*, setting the drive *Enable Parameter* (06.015) to OFF (0) or disabling the drive via the control word (Pr **06.042** & Pr **06.043**).

###### • Locked rotor test

This test can be used to measure the parameters necessary to operate in sensorless mode at low speeds using signal injection, or to exploit the torque produced from saliency, provided all the basic control parameters have been set-up correctly. The test can only be carried out if the rotor is locked in such a way that it will not move even when a torque producing current equal to *Rated Current* (05.007) is applied to the motor. *Rated Load Lq* (05.069), *Rated Load Offset* (05.071) and *Maximum Low Speed Sensorless Mode Current* (05.072) are measured. To perform a *Rotating* autotune, set Pr **00.040** to 4, and provide the drive with both an enable signal (terminal 31 on *Unidrive HS70 / HS71* and terminal 11 & 13 on *Unidrive HS72*) and a run signal (terminal 26 or 27 on *Unidrive HS70 / HS71* and terminal 7 or 8 on *Unidrive HS72*).

### Pr 00.038 {04.013} / Pr 00.039 {04.014} Current Loop Gains

The current loop gains proportional (Kp) and integral (Ki) gains control the response of the current loop to a change in current (torque) demand. The default values give satisfactory operation with most motors. However, for optimal performance in dynamic applications it may be necessary to change the gains to improve the performance. The proportional gain (Pr 04.013) is the most critical value in controlling the performance. The values for the current loop gains can be calculated by performing a stationary or rotating autotune (see *Autotune* Pr 00.040, earlier in this table) the drive measures the *Stator Resistance* (05.017) and *Transient Inductance* (05.024) of the motor and calculates the current loop gains.

This will give a step response with minimum overshoot after a step change of current reference. The proportional gain can be increased by a factor of 1.5 giving a similar increase in bandwidth; however, this gives a step response with approximately 12.5 % overshoot. The equation for the integral gain gives a conservative value. In some applications where it is necessary for the reference frame used by the drive to dynamically follow the flux very closely (i.e. high speed Sensorless RFC-A induction motor applications) the integral gain may need to have a significantly higher value.

#### Speed loop gains

(Pr 00.007 {03.010}, Pr 00.008 {03.011}, Pr 00.009 {03.012})

The speed loop gains control the response of the speed controller to a change in speed demand. The speed controller includes proportional (Kp) and integral (Ki) feed forward terms, and a differential (Kd) feedback term. The drive holds two sets of these gains and either set may be selected for use by the speed controller with Pr 03.016. If Pr 03.016 = 0, gains Kp1, Ki1 and Kd1 (Pr 00.007 to Pr 00.009) are used, and if Pr 03.016 = 1, gains Kp2, Ki2 and Kd2 (Pr 03.013 to Pr 03.015) are used. Pr 03.016 may be changed when the drive is enabled or disabled. If the load is predominantly a constant inertia and constant torque, the drive can calculate the required Kp and Ki gains to give a required compliance angle or bandwidth dependant on the setting of Pr 03.017.

*Speed Controller Proportional Gain (Kp)*, Pr 00.007 {03.010} and Pr 03.013

If the proportional gain has a value and the integral gain is set to zero the controller will only have a proportional term, and there must be a speed error to produce a torque reference. Therefore as the motor load increases there will be a difference between the reference and actual speeds. This effect, called regulation, depends on the level of the proportional gain, the higher the gain the smaller the speed error for a given load. If the proportional gain is too high either the acoustic noise produced by speed feedback quantization becomes unacceptable, or the stability limit is reached.

*Speed Controller Integral Gain (Ki)*, Pr 00.008 {03.011} and Pr 03.014

The integral gain is provided to prevent speed regulation. The error is accumulated over a period of time and used to produce the necessary torque demand without any speed error. Increasing the integral gain reduces the time taken for the speed to reach the correct level and increases the stiffness of the system, i.e. it reduces the positional displacement produced by applying a load torque to the motor. Unfortunately increasing the integral gain also reduces the system damping giving overshoot after a transient. For a given integral gain the damping can be improved by increasing the proportional gain. A compromise must be reached where the system response, stiffness and damping are all adequate for the application. For RFC-A Sensorless mode, it is unlikely that the integral gain can be increased much above 0.50.

*Differential Gain (Kd)*, Pr 00.009 {03.012} and Pr 03.015

The differential gain is provided in the feedback of the speed controller to give additional damping. The differential term is implemented in a way that does not introduce excessive noise normally associated with this type of function. Increasing the differential term reduces the overshoot produced by under-damping, however, for most applications the proportional and integral gains alone are sufficient.

### Speed loop gains (cont)

(Pr 00.007 {03.010}, Pr 00.008 {03.011}, Pr 00.009 {03.012})

There are three methods of tuning the speed loop gains dependant on the setting of Pr 03.017:

- Pr 03.017 = 0, User set-up.  
This involves the connecting of an oscilloscope to analog output 1 to monitor the speed feedback.  
Give the drive a step change in speed reference and monitor the response of the drive on the oscilloscope.  
The proportional gain (Kp) should be set up initially. The value should be increased up to the point where the speed overshoots and then reduced slightly.  
The integral gain (Ki) should then be increased up to the point where the speed becomes unstable and then reduced slightly.  
It may now be possible to increase the proportional gain to a higher value and the process should be repeated until the system response matches the ideal response as shown.  
The diagram shows the effect of incorrect P and I gain settings as well as the ideal response.
- Pr 03.017 = 1, Bandwidth set-up  
If bandwidth based set-up is required, the drive can calculate Kp and Ki if the following parameters are set up correctly:  
Pr 03.020 - Required bandwidth,  
Pr 03.021 - Required damping factor,  
Pr 03.018 - Motor and load inertia.  
The drive can be made to measure the motor and load inertia by performing an inertia measurement autotune (see *Autotune* Pr 00.040, earlier in this table).
- Pr 03.017 = 2, Compliance angle set-up  
If compliance angle based set-up is required, the drive can calculate Kp and Ki if the following parameters are set up correctly:  
Pr 03.019 - Required compliance angle,  
Pr 03.021 - Required damping factor,  
Pr 03.018 - Motor and load inertia  
The drive can be made to measure the motor and load inertia by performing an inertia measurement autotune (see *Autotune* Pr 00.040, earlier in this table).
- Pr 03.017 = 3, Kp gains times 16  
If *Speed Controller Set-up Method* (03.017) = 3 the selected proportional gain used by the drive is multiplied by 16.

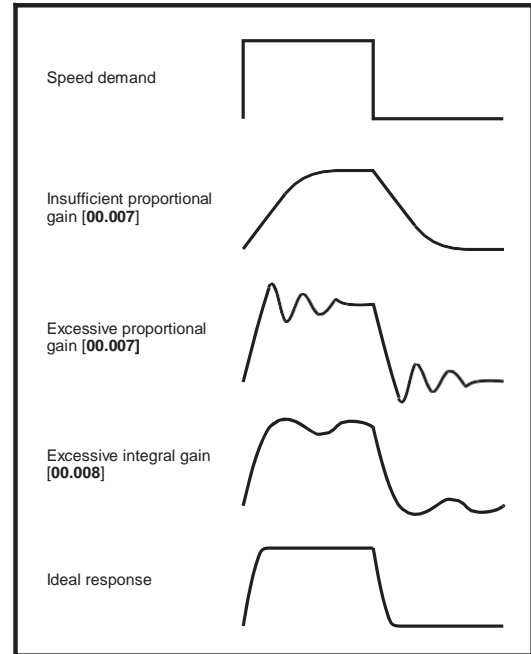

### 5. Pr 03.017 = 4 - 6

If *Speed Controller Set-up Method* (03.017) is set to a value from 4 to 6 the *Speed Controller Proportional Gain Kp1* (03.010) and *Speed Controller Integral Gain Ki1* (03.011) are automatically set up to give the bandwidths given in the table below and a damping factor of unity. These settings give low, standard or high performance.

Speed Controller Set-up Method (03.017)	Performance	Bandwidth
4	Low	5 Hz
5	Standard	25 Hz
6	High	100 Hz

## 7.2 Maximum motor rated current

The maximum motor rated current allowed by the drive is greater than the *Maximum Heavy Duty Current Rating* (11.032). The ratio between the Normal Duty rating and the *Maximum Heavy Duty Current Rating* (11.032) varies between drive sizes. The values for the Normal and Heavy Duty rating can be found in section 2.3 *Ratings* on page 9. If the motor *Rated Current* (00.046) is set above the *Maximum Heavy Duty Current Rating* (11.032), the current limits and the motor thermal protection scheme are modified (see section 7.3 *Current limits* on page 86 and section 7.4 *Motor thermal protection* on page 86 for more information).

## 7.3 Current limits

The default setting for the current limit parameters is:

- 165 % x motor rated current for open loop mode
- 175 % x motor rated current for RFC-A and RFC-S modes

There are three parameters which control the current limits:

- Motoring current limit: power flowing from the drive to the motor
- Regen current limit: power flowing from the motor to the drive
- Symmetrical current limit: current limit for both motoring and regen operation

The lowest of either the motoring and regen current limit, or the symmetrical current limit applies.

The maximum setting of these parameters depends on the values of motor rated current, drive rated current and the power factor.

Increasing the motor rated current (Pr **00.046/05.007**) above the Heavy Duty rating (default value), will automatically reduce the current limits in Pr **04.005** to Pr **04.007**. If the motor rated current is then set to or below the Heavy Duty rating, the current limits will be left at their reduced values.

The drive can be oversized to permit a higher current limit setting to provide higher accelerating torque as required up to a maximum of 1000 %.

## 7.4 Motor thermal protection

A dual time constant thermal model is provided to estimate the motor temperature as a percentage of its maximum allowed temperature.

The motor thermal protection is modelled using losses in the motor. The losses in the motor are calculated as a percentage value, so that under these conditions the *Motor Protection Accumulator* (04.019) would eventually reach 100 %.

$$\text{Percentage losses} = 100 \% \times [\text{Load related losses} + \text{Iron losses}]$$

Where:

$$\text{Load related losses} = (1 - K_{fe}) \times (I / (K_1 \times I_{\text{Rated}}))^2$$

$$\text{Iron losses} = K_{fe} \times (w / w_{\text{Rated}})^{1.6}$$

Where:

$$I = \text{Current Magnitude (04.001)}$$

$$I_{\text{Rated}} = \text{Rated Current (05.007)}$$

$$K_{fe} = \text{Rated Iron Losses As Percentage Of Losses (04.039)} / 100 \%$$

The *Motor Protection Accumulator* (04.019) is given by:

$$\text{Pr } 04.019 = \text{Percentage Losses} \times [(1 - K_2) (1 - e^{-t/\tau_1}) + K_2 (1 - e^{-t/\tau_2})]$$

Where:

$$T = \text{Motor Protection Accumulator (04.019)}$$

$$K_2 = \text{Motor Thermal Time Constant 2 Scaling (04.038)} / 100 \%$$

$$\tau_1 = \text{Motor Thermal Time Constant 1 (04.015)}$$

$$\tau_2 = \text{Motor Thermal Time Constant 2 (04.037)}$$

$$K_1 = \text{Varies, see below}$$

If *Rated Current* (05.007)  $\leq$  *Maximum Heavy Duty Current* (11.032)

Figure 7-1 Motor thermal protection (Heavy Duty)

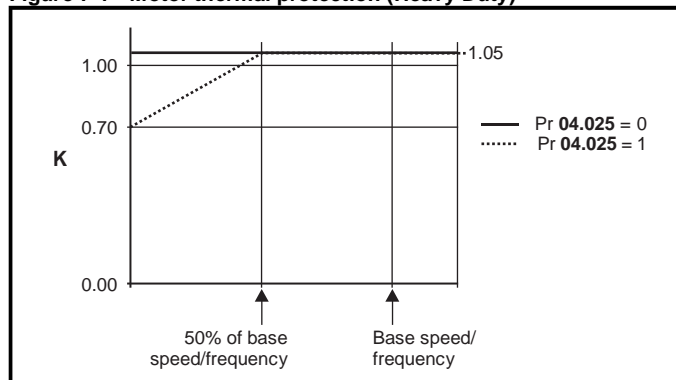

If Pr **04.025** is 0 the characteristic is for a motor which can operate at rated current over the whole speed range. Induction motors with this type of characteristic normally have forced cooling. If Pr **04.025** is 1 the characteristic is intended for motors where the cooling effect of motor fan reduces with reduced motor speed below 50 % of base speed/frequency. The maximum value for K1 is 1.05, so that above the knee of the characteristics the motor can operate continuously up to 105 % current.

Figure 7-2 Motor thermal protection (Normal Duty)

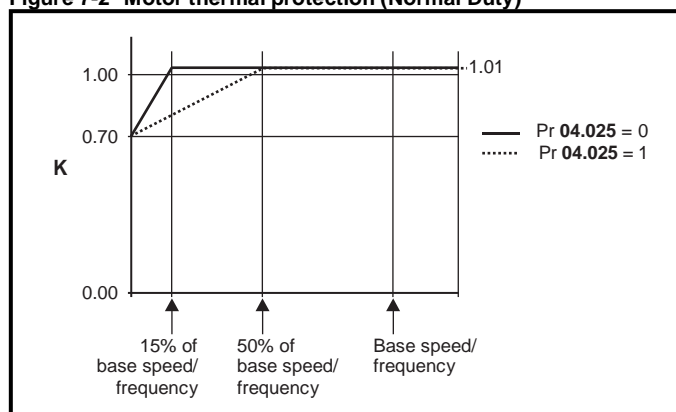

Both settings of Pr **04.025** are intended for motors where the cooling effect of the motor fan reduces with reduced motor speed, but with different speeds below which the cooling effect is reduced. If Pr **04.025** is 0 the characteristic is intended for motors where the cooling effect reduces with motor speed below 15 % of base speed/frequency. If Pr **04.025** is 1 the characteristic is intended for motors where the cooling effect reduces with motor speed below 50 % of base speed/frequency. The maximum value for K1 is 1.01, so that above the knee of the characteristics the motor can operate continuously up to 101 % current.

When the estimated temperature in Pr **04.019** reaches 100 % the drive takes some action depending on the setting of Pr **04.016**. If Pr **04.016** is 0, the drive trips when Pr **04.019** reaches 100 %. If Pr **04.016** is 1, the current limit is reduced to  $(K - 0.05) \times 100 \%$  when Pr **04.019** reaches 100 %.

The current limit is set back to the user defined level when Pr **04.019** falls below 95 %. The thermal model temperature accumulator is reset to zero at power-up and accumulates the temperature of the motor while them drive remains powered-up. If the rated current defined by Pr **05.007** is altered, the accumulator is reset to zero.

The default setting of the thermal time constant (Pr **04.015**) is 89 s which is equivalent to an overload of 150 % for 60 s from cold.

## 7.5 Switching frequency

The default switching frequency is 3 kHz (6 kHz in RFC-S mode), however this can be increased up to a maximum of 16 kHz by Pr **05.018** (dependent on drive size). The available switching frequencies are shown below.

**Table 7-1 Available switching frequencies**

Drive size	Model	2 kHz	3 kHz	4 kHz	6 kHz	8 kHz	12 kHz	16 kHz
3	All							
4								
5								
6		✓	✓	✓	✓	✓	✓	✓
7								
8								
9E								
10	10202830 to 10203000							
	10501520 to 10501900	✓	✓	✓	✓	✓	✓	✓
	10601500 to 10601780							
	10402700 to 10403200	✓	✓	✓	✓			

If switching frequency is increased from 3 kHz the following apply:

- Increased heat loss in the drive, which means that derating to the output current must be applied.  
See the derating tables for switching frequency and ambient temperature in *section 11.1.1 Supply requirements* on page 191.
- Reduced heating of the motor - due to improved output waveform quality.
- Reduced acoustic noise generated by the motor.
- Increased sample rate on the speed and current controllers. A trade off must be made between motor heating, drive heating and the demands of the application with respect to the sample time required.

**Table 7-2 Sample rates for various control tasks at each switching frequency**

Level	3, 6, 12 kHz	2, 4, 8, 16 kHz	Open loop	RFC-A RFC-S
Level 1	3 kHz - 167 μs 6 kHz - 83 μs 12 kHz - 83 μs	2 kHz - 250 μs 4 kHz - 125 μs 8 kHz - 62.5 μs 16 kHz - 62.5 μs	Peak limit	Current controllers
Level 2	250 μs	2 kHz - 500 μs 4 kHz - 250 μs 8 kHz - 250 μs 16 kHz - 250 μs	Current limit and ramps	Speed controller and ramps
Level 3	1 ms		Voltage controller	
Level 4	4 ms		Time critical user interface	
Background			Non-time critical user interface	

## 7.6 High speed operation

### 7.6.1 Encoder feedback limits

The maximum encoder frequency should be prevented from exceeding 500 kHz. In RFC-A and RFC-S modes the maximum speed that can be entered in to the speed reference clamps (Pr **01.006** and Pr **01.007**) can be limited by the drive. This is defined by the following (subject to an absolute maximum of 40,000 rpm):

$$\text{Maximum speed limit (rpm)} = \frac{500 \text{ kHz} \times 60}{\text{ELPR}}$$

$$= \frac{3.0 \times 10^7}{\text{ELPR}}$$

Where:

ELPR is the equivalent encoder lines per revolution and is the number of lines that would be produced by a quadrature encoder.

- Quadrature encoder ELPR = number of lines per revolution
- F and D encoder ELPR = number of lines per revolution / 2
- SINCOS encoder ELPR = number of sine waves per revolution

This maximum speed limit is defined by the device selected with the speed feedback selector (Pr **03.026**), and the ELPR set for the position feedback device. In RFC-A mode it is possible to disable this limit via Pr **03.024**, so that the drive can be switched between operation with and without feedback when the speed becomes too high for the feedback device. The maximum speed limit is defined as above when Pr **03.024** = 0 and is 36,000 rpm when Pr **03.024** = 1, 2, 3 or 4.

### 7.6.2 Field weakening (constant power) operation

(Open loop and RFC-A mode only)

The drive can be used to run an induction machine above synchronous speed into the constant power region. The speed continues to increase and the available shaft torque reduces. The characteristics below show the torque and output voltage characteristics as the speed is increased above the rated value.

**Figure 7-3 Torque and rated voltage against speed**

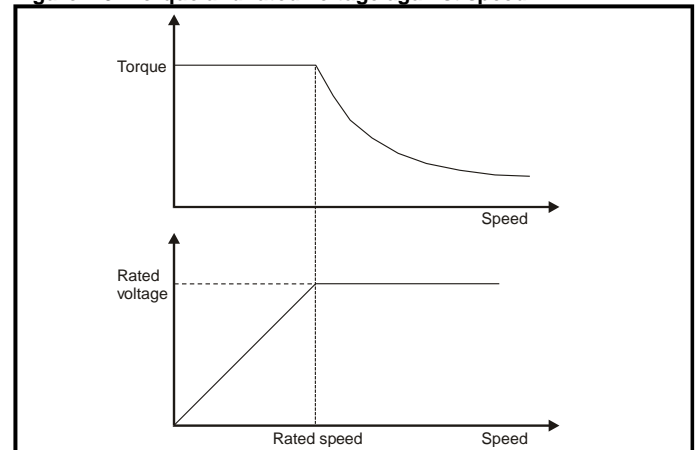

Care must be taken to ensure the torque available above base speed is sufficient for the application to run satisfactorily. The saturation breakpoint parameters (Pr **05.029**, Pr **05.030**, Pr **05.062** and Pr **05.063**) found during the autotune in RFC-A mode ensure the magnetizing current is reduced in the correct proportion for the specific motor. (In open loop mode the magnetizing current is not actively controlled).

### 7.6.3 Permanent magnet motor high speed operation

High speed servo mode is enabled by setting Pr **05.022** = 1. Care must be taken when using this mode with permanent magnet motor to avoid damaging the drive. The voltage produced by the permanent magnet motor magnets is proportional to speed. For high speed operation the drive must apply currents to the motor to counter-act the flux produced by the magnets. It is possible to operate the motor at very high speeds that would give a very high motor terminal voltage, but this voltage is prevented by the action of the drive.

If however, the drive is disabled (or tripped) when the motor voltages would be higher than the rating of the drive without the currents to counter-act the flux from the magnets, it is possible to damage the drive. If high speed mode is enabled the motor speed must be limited to the levels given in the table below unless an additional hardware protection system is used to limit the voltages applied to the drive output terminals to a safe level.

Drive voltage rating	Maximum motor speed (rpm)	Maximum safe line to line voltage at the motor terminals (V rms)
200	$400 \times 1000 / (K_e \times \sqrt{2})$	$400 / \sqrt{2}$
400	$800 \times 1000 / (K_e \times \sqrt{2})$	$800 / \sqrt{2}$
575	$955 \times 1000 / (K_e \times \sqrt{2})$	$955 / \sqrt{2}$
690	$1145 \times 1000 / (K_e \times \sqrt{2})$	$1145 / \sqrt{2}$

$K_e$  is the ratio between r.m.s. line to line voltage produced by the motor and the speed in V/1000 rpm. Care must also be taken not to demagnetize the motor. The motor manufacturer should always be consulted before using this mode.

#### 7.6.4 Maximum speed / frequency

In all open loop mode the maximum achievable output frequency is 3,000 Hz.

In RFC-A and RFC-S modes, the maximum achievable output frequency is 1,250Hz.

In RFC-S mode the speed is also limited by the voltage constant ( $K_e$ ) of the motor unless field weakening operation is enabled.  $K_e$  is a specific constant for the servo motor being used. It can normally be found on the motor data sheet in V/k rpm (volts per 1,000 rpm).

It is recommended that a minimum ratio of 12:1 is maintained between the switching frequency and the maximum output frequency to maintain the quality of the output waveform. If this minimum ratio is exceeded, extra motor losses will result due to the increased harmonic content of the output waveform.

#### 7.6.5 Quasi-Square wave (open-loop only)

The maximum output voltage level of the drive is normally limited to an equivalent of the drive input voltage minus voltage drops within the drive (the drive will also retain a few percent of the voltage in order to maintain current control). If the motor rated voltage is set at the same level as the supply voltage, some pulse deletion will occur as the drive output voltage approaches the rated voltage level. If Pr **05.020** (Quasi-square wave enable) is set to 1 the modulator will allow over modulation, so that as the output frequency increases beyond the rated frequency the voltage continues to increase above the rated voltage. The modulation depth will increase beyond unity; first producing trapezoidal and then quasi-square waveforms.

This can be used for example:

- To obtain high output frequencies with a low switching frequency which would not be possible with space vector modulation limited to unity modulation depth,

or

- In order to maintain a higher output voltage with a low supply voltage.

The disadvantage is that the machine current will be distorted as the modulation depth increases above unity, and will contain a significant amount of low order odd harmonics of the fundamental output frequency. The additional low order harmonics cause increased losses and heating in the motor.

## 8 NV Media Card Operation

### 8.1 Introduction

The Non-Volatile Media Card feature enables simple configuration of parameters, parameter back-up, storing / reading PLC programs and drive copying using a SMARTCARD or SD card storing / reading PLC programs. The drive offers backward compatibility for a Unidrive SP SMARTCARD.

The NV Media Card can be used for:

- Parameter copying between drives
- Saving drive parameter sets
- Saving an onboard user program

The NV Media Card is located at the top of the module under the drive display (if installed) on the left-hand side.

Ensure the NV Media Card is inserted with the contacts facing the left-hand side of the drive.

The drive only communicates with the NV Media Card when commanded to read or write, meaning the card may be "hot swapped".



Beware of possible live terminals when installing the NV Media Card.

**WARNING**

Figure 8-1 Installation of the NV Media Card

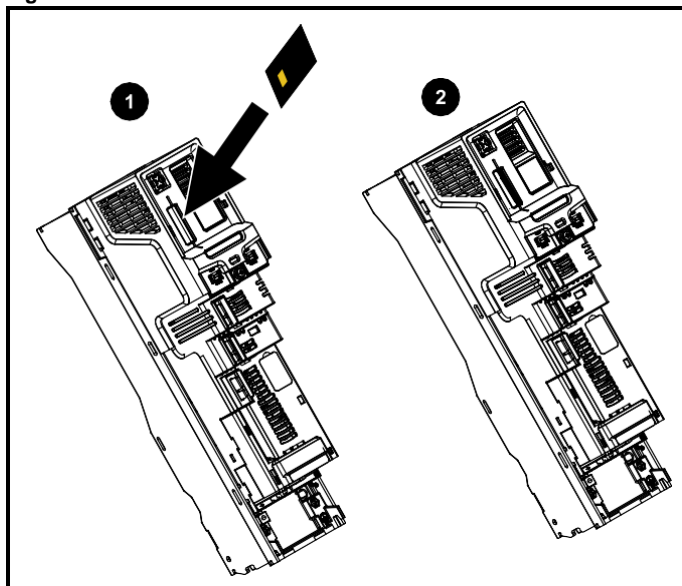

1. Installing the NV Media Card
2. NV Media Card installed

NV Media Card	Part number
SD Card Adaptor (memory card not included)	3130-1212-03
8 kB SMARTCARD	2214-4246-03
64 kB SMARTCARD	2214-1006-03

### 8.2 NV Media Card support

The NV Media Card can be used to store drive parameter sets and / or PLC programs set from the Unidrive HS in data blocks 001 to 499 on the card.

The Unidrive HS is compatible with a Unidrive SP SMARTCARD and is able to read and translate the Unidrive SP parameter set into a compatible parameter set for Unidrive HS. This is only possible if the Unidrive SP parameter set was transferred to the SMARTCARD using the difference from defaults transfer method (i.e. 4yyy transfer). The

Unidrive HS is not able to read any other type of Unidrive SP data block on the card. Although it is possible to transfer difference from default data blocks from a Unidrive SP into the Unidrive HS, the following should be noted:

1. If a parameter from the source drive does not exist in the target drive then no data is transferred for that parameter.
2. If the data for the parameter in the target drive is out of range then the data is limited to the range of the target parameter.
3. If the target drive has a different rating to the source drive then the normal rules for this type of transfer apply.

Figure 8-2 Basic NV Media Card operation



The whole card may be protected from writing or erasing by setting the read-only flag as detailed section 8.3.9 9888 / 9777 - *Setting and clearing the NV Media Card read only flag* on page 91.

The card should not be removed during data transfer, as the drive will produce a trip. If this occurs then either the transfer should be reattempted or in the case of a card to drive transfer, default parameters should be loaded.

## 8.3 Transferring data

Data transfer, erasing and protecting the information is performed by entering a code in Pr **mm.000** and then resetting the drive as shown in Table 8-1.

**Table 8-1 SMARTCARD and SD card codes**

Code	Operation	SMARTCARD	SD card
2001	Transfer the drive parameters to parameter file 001 and sets the block as bootable. This will include the parameters from attached option modules.	✓	✓
4yyy	Transfer the drive parameters to parameter file yyy. This will include the parameters from attached option modules.	✓	✓
5yyy	Transfer the onboard user program to onboard user program file yyy.	✓	✓
6yyy	Load the drive parameters from parameter file yyy or the onboard user program from onboard user program file yyy.	✓	✓
7yyy	Erase file yyy.	✓	✓
8yyy	Compare the data in the drive with file yyy. If the files are the same then <i>Pr mm.000 (mm.000)</i> is simply reset to 0 when the compare is complete. If the files are different a 'Card Compare' trip is initiated. All other NV media card trips also apply.	✓	✓
9555	Clear the warning suppression flag	✓	✓
9666	Set the warning suppression flag	✓	✓
9777	Clear the read-only flag	✓	✓
9888	Set the read-only flag	✓	✓
9999	Erase and format the NV media card	✓	✓
15yyy	Transfer a program from an option module in slot 1 to an option module applications file		✓
16yyy	As 15yyy, but for slot 2		✓
17yyy	As 15yyy, but for slot 3		✓
18yyy	Load a program to the option module in slot 1 from an option module applications file		✓
19yyy	As 18yyy, but for slot 2		✓
20yyy	As 18yyy, but for slot 3		✓
21yyy	As 15yyy, but for slot 4		✓
22yyy	As 18yyy, but for slot 4		✓
40yyy	Backup all drive data (parameter differences from defaults, an onboard user program, applications programs and miscellaneous option data), including the drive name; the store will occur to the <MCD/ driveyyy/> folder; if it does not exist, it will be created. Because the name is stored, this is a backup, rather than a copy. The command code will be cleared when all drive and option data have been saved.		✓
60yyy	Load all drive data (parameter differences from defaults, an onboard user program, applications programs and miscellaneous option data); the load will come from the <MCD/ driveyyy/> folder. The command code will not be cleared until the drive and all option data have been loaded.		✓

Where yyy indicates the block number 001 to 999.

### NOTE

If the read only flag is set then only codes 6yyy or 9777 are effective.

### 8.3.1 Writing to the NV Media Card

#### 4yyy - Writes defaults differences to the NV Media Card

The data block only contains the parameter differences from the last time default settings were loaded.

All parameters except those with the NC (Not copied) coding bit set are transferred to the NV Media Card. In addition to these parameters all menu 20 parameters (except Pr **20.000**), can be transferred to the NV Media Card.

#### Writing a parameter set to the NV Media Card (Pr 11.042 = Program (2))

Setting Pr **11.042** to Program (2) and resetting the drive will save the parameters to the NV Media Card, i.e. this is equivalent to writing 4001 to Pr **mm.000**. All NV Media Card trips apply except 'Card Change'. If the data block already exists it is automatically overwritten. When the action is complete this parameter is automatically reset to None (0).

### 8.3.2 Reading from the NV Media Card

#### 6yyy - Reading from NV Media Card

When the data is transferred back to the drive, using 6yyy in Pr **mm.000**, it is transferred to the drive RAM and the EEPROM. A parameter save is not required to retain the data after-power down. Set up data for any option modules installed stored on the card are transferred to the drive. If the option modules installed are different between source and destination drives, the menus for the option module slots where the option module categories are different are not updated from the card and will contain their default values after the copying action. The drive will produce a 'Card Option' trip if the option module installed to the source and the destination drives are different or are in different slots. If the data is being transferred to the drive with different voltage or current rating a 'Card Rating' trip will occur.

The following drive rating dependant parameters (RA coding bit set) will not be transferred to the destination drive by a NV Media Card when the voltage rating of the destination drive is different from the source drive and the file is a parameter file.

Safety information	Product information	Electrical installation	Getting started	Basic parameters	Running the motor	Optimization	<b>NV Media Card Operation</b>	Onboard PLC	Advanced parameters	Technical data	Diagnostics	UL listing information
--------------------	---------------------	-------------------------	-----------------	------------------	-------------------	--------------	--------------------------------	-------------	---------------------	----------------	-------------	------------------------

However, drive rating dependent parameters will be transferred if only the current rating is different. If drive rating dependant parameters are not transferred to the destination drive they will contain their default values.

Pr **02.008** *Standard Ramp Voltage*

Pr **04.005** to Pr **04.007** and Pr **21.027** to Pr **21.029** *Motoring Current Limits*

Pr **04.024**, *User Current Maximum Scaling*

Pr **05.007**, Pr **21.007** *Rated Current*

Pr **05.009**, Pr **21.009** *Rated Voltage*

Pr **05.010**, Pr **21.010** *Rated Power Factor*

Pr **05.017**, Pr **21.012** *Stator Resistance*

Pr **05.018** *Maximum Switching Frequency*

Pr **05.024**, Pr **21.014** *Transient Inductance*

Pr **05.025**, Pr **21.024** *Stator Inductance*

Pr **06.006** *Injection Braking Level*

Pr **06.048** *Supply Loss Detection Level*

Pr **06.065** *Standard Under Voltage Threshold*

Pr **06.066** *Low Under Voltage Threshold*

### Reading a parameter set from the NV Media Card (Pr 11.042 = Read (1))

Setting Pr **11.042** to Read (1) and resetting the drive will transfer the parameters from the card into the drive parameter set and the drive EEPROM, i.e. this is equivalent to writing 6001 to Pr **mm.000**.

All NV Media Card trips apply. Once the parameters are successfully copied this parameter is automatically reset to None (0). Parameters are saved to the drive EEPROM after this action is complete.

### 8.3.3 Auto saving parameter changes (Pr 11.042 = Auto (3))

This setting causes the drive to automatically save any changes made to menu 0 parameters on the drive to the NV Media Card. The latest menu 0 parameter set in the drive is therefore always backed up on the NV Media Card. Changing Pr **11.042** to Auto (3) and resetting the drive will immediately save the complete parameter set from the drive to the card, i.e. all parameters except parameters with the NC coding bit set. Once the whole parameter set is stored only the individual modified menu 0 parameter setting is updated.

Advanced parameter changes are only saved to the NV Media Card when Pr **mm.000** is set to 'Save Parameters' or a 1000 and the drive reset.

All NV Media Card trips apply, except 'Card Change'. If the data block already contains information it is automatically overwritten.

If the card is removed when Pr **11.042** is set to 3 Pr **11.042** is then automatically set to None (0).

When a new NV Media Card is installed Pr **11.042** must be set back to Auto (3) by the user and the drive reset so the complete parameter set is rewritten to the new NV Media Card if auto mode is still required.

When Pr **11.042** is set to Auto (3) and the parameters in the drive are saved, the NV Media Card is also updated, and therefore the NV Media Card becomes a copy of the drives stored configuration.

At power up, if Pr **11.042** is set to Auto (3), the drive will save the complete parameter set to the NV Media Card. The drive will display 'Card Write' during this operation. This is done to ensure that if a user puts a new NV Media Card in during power down the new NV Media Card will have the correct data.

#### NOTE

When Pr **11.042** is set to Auto (3) the setting of Pr **11.042** itself is saved to the drive EEPROM but not the NV Media Card.

### 8.3.4 Booting up from the NV Media Card on every power up (Pr 11.042 = Boot (4))

When Pr **11.042** is set to Boot (4) the drive operates the same as Auto mode except when the drive is powered-up. The parameters on the NV Media Card will be automatically transferred to the drive at power up if the following are true:

- A card is inserted in the drive
- Parameter data block 1 exists on the card
- The data in block 1 is type 1 to 4 (as defined in Pr **11.038**)
- Pr **11.042** on the card set to Boot (4)

The drive will display 'Booting Parameters' during this operation. If the drive mode is different from that on the card, the drive gives a 'Card Drive Mode' trip and the data is not transferred.

If 'Boot' mode is stored on the copying NV Media Card this makes the copying NV Media Card the master device. This provides a very fast and efficient way of re-programming a number of drives.

#### NOTE

'Boot' mode is saved to the card, but when the card is read, the value of Pr **11.042** is not transferred to the drive.

### 8.3.5 Booting up from the NV Media Card on every power up (Pr mm.000 = 2001)

It is possible to create a bootable parameter data block by setting Pr **mm.000** to 2001 and initiating a drive reset. This data block is created in one operation and is not updated when further parameter changes are made.

Setting Pr **mm.000** to 2001 will overwrite the data block 1 on the card if it already exists.

### 8.3.6 8yyy - Comparing the drive full parameter set with the NV Media Card values

Setting 8yyy in Pr **mm.000**, will compare the NV Media Card file with the data in the drive. If the compare is successful Pr **mm.000** is simply set to 0. If the compare fails a 'Card Compare' trip is initiated.

### 8.3.7 7yyy / 9999 - Erasing data from the NV Media Card values

Data can be erased from the NV Media Card either one block at a time or all blocks in one go.

- Setting 7yyy in Pr **mm.000** will erase NV Media Card data block yyy
- Setting 9999 in Pr **mm.000** will erase all NV Media Card data blocks

### 8.3.8 9666 / 9555 - Setting and clearing the NV Media Card warning suppression flag

If the option modules installed to the source and destination drive are different or are in different slots the drive will produce a 'Card Option' trip. If the data is being transferred to a drive of a different voltage or current rating a 'Card Rating' trip will occur. It is possible to suppress these trips by setting the warning suppression flag. If this flag is set the drive will not trip if the option module(s) or drive ratings are different between the source and destination drives. The options module or rating dependent parameters will not be transferred.

- Setting 9666 in Pr **mm.000** will set the warning suppression flag
- Setting 9555 in Pr **mm.000** will clear the warning suppression flag

### 8.3.9 9888 / 9777 - Setting and clearing the NV Media Card read only flag

The NV Media Card may be protected from writing or erasing by setting the read only flag. If an attempt is made to write or erase a data block when the read only flag is set, a 'Card Read Only' trip is initiated. When the read only flag is set only codes 6yyy or 9777 are effective.

- Setting 9888 in Pr **mm.000** will set the read only flag
- Setting 9777 in Pr **mm.000** will clear the read only flag

## 8.4 Data block header information

Each data block stored on a NV Media Card has header information detailing the following:

- *NV Media Card File Number* (11.037)
- *NV Media Card File Type* (11.038)
- *NV Media Card File Version* (11.039)
- *NV Media Card File Checksum* (11.040)

The header information for each data block which has been used can be viewed in Pr **11.038** to Pr **11.040** by increasing or decreasing the data

block number set in Pr 11.037. If there is no data on the card Pr 11.037 can only have a value of 0.

## 8.5 NV Media Card parameters

Table 8-2 Key to parameter table coding

RW	Read / Write	ND	No default value
RO	Read only	NC	Not copied
Num	Number parameter	PT	Protected parameter
Bit	Bit parameter	RA	Rating dependant
Txt	Text string	US	User save
Bin	Binary parameter	PS	Power-down save
FI	Filtered	DE	Destination

11.036 {00.029}		NV Media Card File Previously Loaded	
RO	Num	NC	PT
OL			
RFC-A	↕	0 to 999	⇒ 0
RFC-S			

This parameter shows the number of the data block last transferred from a NV Media Card to the drive. If defaults are subsequently reloaded this parameter is set to 0.

11.037		NV Media Card File Number	
RW	Num	NC	PT
OL			
RFC-A	↕	0 to 999	⇒ 0
RFC-S			

This parameter should have the data block number which the user would like the information displayed in Pr 11.038, Pr 11.039 and Pr 11.040.

11.038		NV Media Card File Type	
RO	Txt	ND	NC
OL			
RFC-A	↕	None (0), Open-loop (1), RFC-A (2), RFC-S (3), Regen (4), User Prog (5), Option App (6)	⇒
RFC-S			

Displays the type/mode of the data block selected with Pr 11.037.

Pr 11.038	String	Type / mode
0	None	No file selected
1	Open-loop	Open-loop mode parameter file
2	RFC-A	RFC-A mode parameter file
3	RFC-S	RFC-S mode parameter file
4	Regen	Regen mode parameter file
5	User Prog	Onboard user program file
6	Option App	Option module application file

11.039		NV Media Card File Version	
RO	Num	ND	NC
OL			
RFC-A	↕	0 to 9999	⇒
RFC-S			

Displays the version number of the file selected in Pr 11.037.

11.040		NV Media Card File Checksum	
RO	Num	ND	NC
OL			
RFC-A	↕	--2147483648 to 2147483647	⇒
RFC-S			

Displays the checksum of the data block selected in Pr 11.037.

11.042		Parameter Cloning	
RW	Txt	NC	US*
OL			
RFC-A	↕	None (0), Read (1), Program (2), Auto (3), Boot (4)	⇒ None (0)
RFC-S			

\* Only a value of 3 or 4 in this parameter is saved.

### NOTE

If Pr 11.042 is equal to 1 or 2, this value is not transferred to the drive or saved to the EEPROM. If Pr 11.042 is set to 3 or 4 the value is saved to the EEPROM

None (0) = Inactive

Read (1) = Read parameter set from the NV Media Card

Program (2) = Program a parameter set to the NV Media Card

Auto (3) = Auto save

Boot (4) = Boot mode

11.072		NV Media Card Create Special File	
RW	Num	NC	PT
OL			
RFC-A	↕	0 to 1	⇒ 0
RFC-S			

If *NV Media Card Create Special File* (11.072) = 1 when a parameter file is transferred to an NV media card the file is created as a macro file. *NV Media Card Create Special File* (11.072) is reset to 0 after the file is created or the transfer fails.

## 8.6 NV Media Card trips

After an attempt to read, write or erase data from a NV Media Card a trip is initiated if there has been a problem with the command.

See Chapter 12 *Diagnostics* on page 194 for more information on NV Media Card trips.

11.073		NV Media Card Type											
RO	Txt					ND	NC	PT					
OL		None (0), SMART Card (1), SD Card (2)										⇒	
RFC-A	⇕												
RFC-S													

This will display the type of media card inserted; it will contain one of the following values:

"None" (0) - No NV Media Card has been inserted.

"SMART Card" (1) - A SMARTCARD has been inserted.

"SD Card" (2) - A FAT formatted SD card has been inserted.

11.075		NV Media Card Read-only Flag											
RO	Bit					ND	NC	PT					
OL		Off (0) or On (1)										⇒	
RFC-A	⇕												
RFC-S													

*NV Media Card Read-only Flag* (11.075) shows the state of the read-only flag for the currently installed card.

11.076		NV Media Card Warning Suppression Flag											
RO	Bit					ND	NC	PT					
OL		Off (0) or On (1)										⇒	
RFC-A	⇕												
RFC-S													

*NV Media Card Warning Suppression Flag* (11.076) shows the state of the warning flag for the currently installed card.

11.077		NV Media Card File Required Version											
RW	Num					ND	NC	PT					
OL		0 to 9999										⇒	
RFC-A	⇕												
RFC-S													

The value of *NV Media Card File Required Version* (11.077) is used as the version number for a file when it is created on an NV Media Card. *NV Media Card File Required Version* (11.077) is reset to 0 when the file is created or the transfer fails.

## 9 Onboard PLC

### 9.1 Onboard PLC and Machine Control Studio

The drive has the ability to store and execute a 16 kB Onboard PLC user program without the need for additional hardware in the form of an option module.

Machine Control Studio is an IEC61131-3 development environment designed for use with Unidrive HS and compatible application modules. Machine Control Studio is based on CODESYS from 3S-Smart Software Solutions.

All of the programming languages defined in the IEC standard IEC 61131-3 are supported in the Machine Control Studio development environment.

- ST (Structured text)
- LD (Ladder diagram)
- FBD (Function block diagram)
- IL (Instruction list)
- SFC (Sequential function chart)
- CFC (Continuous Function Chart). CFC is an extension to the standard IEC programming languages

Machine Control Studio provides a complete environment for the development of user programs. Programs can be created, compiled and downloaded to a Unidrive HS for execution, via the communications port on the front of the drive. The run-time operation of the compiled program on the target can also be monitored using Machine Control Studio and facilities are provided to interact with the program on the target by setting new values for target variables and parameters.

The Onboard PLC and Machine Control Studio form the first level of functionality in a range of programmable options for Unidrive HS.

Machine Control Studio can be downloaded from [www.controltechniques.com](http://www.controltechniques.com).

See the Machine Control Studio help file for more information regarding using Machine Control Studio, creating user programs and downloading user programs to the drive.

### 9.2 Benefits

The combination of the Onboard PLC and Machine Control Studio, means that the drive can replace nano and some micro PLCs in many applications

Machine Control Studio benefits from access to the standard CODESYS function and function block libraries as well as those from third parties. Functions and function blocks available as standard in Machine Control Studio include, but not limited to, the following:

- Arithmetic blocks
- Comparison blocks
- Timers
- Counters
- Multiplexers
- Latches
- Bit manipulation

Typical applications for the Onboard PLC include:

- Ancillary pumps
- Fans and control valves
- Interlocking logic
- Sequences routines
- Custom control words.

### 9.3 Features

The Unidrive HS Onboard PLC user program has the following features:

#### 9.3.1 Tasks

The Onboard PLC allows use of two tasks.

- **Clock:** A high priority real time task. The clock task interval can be set from 16 ms to 262 s in multiples of 16 ms. The parameter *Onboard User Program: Clock Task Time Used* (11.051) shows the percentage of the available time used by clock task. A read or write of a drive parameter by the user program takes a finite period of time. It is possible to select up to 10 parameters as fast access parameter which reduced the amount of time it takes for the user program to read from or write to a drive parameter. This is useful when using a clock task with a fast update rate as selecting a parameter for fast access reduces the amount of the clock task resource required to access parameters.
- **Freewheeling:** A non-real time background task. The freewheeling task is scheduled for a short period once every 256 ms. The time for which the task is scheduled will vary depending on the loading of the drive's processor. When scheduled, several scans of the user program may be performed. Some scans may execute in microseconds. However, when the main drive functions are scheduled there will be a pause in the execution of the program causing some scans to take many milliseconds. The parameter *Onboard User Program: Freewheeling Tasks Per Second* (11.050) shows the number of times the freewheeling task has started per second.

#### 9.3.2 Variables

The Onboard PLC supports the use of variables with the data types of Boolean, integer (8 bit, 16 bit and 32 bit, signed and unsigned), floating point (64 bit only), strings and time.

#### 9.3.3 Custom menu

Machine Control Studio can construct a custom drive menu to reside in menu 30 on the drive. The following properties of each parameter can be defined using Machine Control Studio:

- Parameter name
- Number of decimal places
- The units for the parameter to be display on the keypad.
- The minimum, maximum and default values
- Memory handling (i.e. power down save, user save or volatile)
- Data type. The drive provides a limited set of 1 bit, 8 bit, 16 bit and 32 bit integer parameters to create the customer menu.

Parameters in this customer menu can be accessed by the user program and will appear on the keypad.

#### 9.3.4 Limitations

The Onboard PLC user program has the following limitations:

- The flash memory allocated to the Onboard PLC is 16 kB which includes the user program and its header which results in a maximum user program size of about 12 kB
- The Onboard PLC is provided with 2 kB of RAM.
- The drive is rated for 100 program downloads. This limitation is imposed by the flash memory used to store the program within the drive.
- There is only one real-time task with a minimum period of 16 ms.
- The freewheeling background task runs at a low priority. The drive is prioritized to perform the clock task and its major functions first, e.g. motor control, and will use any remaining processing time to execute the freewheeling task as a background activity. As the drive's processor becomes more heavily loaded, less time is spent executing the freewheeling task.
- Breakpoints, single stepping and online program changes are not possible.
- The Graphing tool is not supported.
- The variable data types REAL (32 bit floating point), LWORD (64 bit integer) and WSTRING (Unicode string), and retained variables are not supported.

## 9.4 Onboard PLC parameters

The following parameters are associated with the Onboard PLC user program.

11.047		Onboard User Program: Enable				
RW	Txt				US	
↕	Stop (0) or Run (1)		⇒		Run (1)	

This parameter stops and starts the user program.

### 0 - Stop the User Program

The onboard user program is stopped. If it is restarted by setting *Onboard User Program: Enable* (11.047) to a non-zero value the background task starts from the beginning.

### 1 - Run the User Program

The user program will execute.

11.048		Onboard User Program: Status				
RO	Txt		NC	PT		
↕	-2147483648 to 2147483647		⇒			

This parameter is read-only and indicates the status of the user program in the drive. The user program writes the value to this parameter.

0: Stopped

1: Running

2: Exception

3: No user program present

11.049		Onboard User Program: Programming Events				
RO	Uni		NC	PT	PS	
↕	0 to 65535		⇒			

This parameter holds the number of times an Onboard PLC user program download has taken place and is 0 on dispatch from the factory. The drive is rated for one hundred ladder program downloads. This parameter is not altered when defaults are loaded.

11.050		Onboard User Program: Freewheeling Tasks Per Second				
RO	Uni		NC	PT		
↕	0 to 65535		⇒			

This parameter shows the number of times the freewheeling task has started per second.

11.051		Onboard User Program: Clock Task Time Used				
RO			NC	PT		
↕	0.0 to 100.0 %		⇒			

This parameter shows the percentage of the available time used by the user program clock task.

11.055		Onboard User Program: Clock Task Scheduled Interval				
RO			NC	PT		
↕	0 to 262128 ms		⇒			

This parameter shows the interval at which the clock task is scheduled to run in ms.

## 9.5 Onboard PLC trips

If the drive detects an error in the user program it will initiate a User Program trip. The sub-trip number for the User Program trip details the reason for the error. See Chapter 12 *Diagnostics* on page 194 for more information on the User Program trip.

## 10 Advanced parameters

This is a quick reference to all parameters in the drive showing units, ranges limits etc, with block diagrams to illustrate their function. Full descriptions of the parameters can be found in the *Parameter Reference Guide*.



**These advanced parameters are listed for reference purposes only. The lists in this chapter do not include sufficient information for adjusting these parameters. Incorrect adjustment can affect the safety of the system, and damage the drive and or external equipment. Before attempting to adjust any of these parameters, refer to the *Parameter Reference Guide*.**

**WARNING**

**Table 10-1 Menu descriptions**

Menu	Description
0	Commonly used basic set up parameters for quick / easy programming
1	Frequency / Speed reference
2	Ramps
3	Frequency slaving, speed feedback and speed control
4	Torque and current control
5	Motor control
6	Sequencer and clock
7	Analog I/O / Temperature monitoring
8	Digital I/O
9	Programmable logic, motorized pot, binary sum, timers and scope
10	Status and trips
11	Drive set-up and identification, serial communications
12	Threshold detectors and variable selectors
13	Standard motion control
14	User PID controller
15	Option module slot 1 set-up menu
16	Option module slot 2 set-up menu
17	Option module slot 3 set-up menu
18	General option module application menu 1
19	General option module application menu 2
20	General option module application menu 3
21	Second motor parameters
22	Menu 0 set-up
23	Not allocated
24	Ethernet module (slot 4) set-up menu*
25	Option module slot 1 application parameters
26	Option module slot 2 application parameters
27	Option module slot 3 application parameters
28	Option module slot 4 application parameters
29	Reserved menu
30	Onboard user programming application menu
31-41	Advanced motion controller setup parameters
Slot 1	Slot 1 option menus**
Slot 2	Slot 2 option menus**
Slot 3	Slot 3 option menus**
Slot 4	Slot 4 option menus**

\* Only displayed on *Unidrive HS70 / HS72*.

\*\* Only displayed when the option modules are installed.

### Operation mode abbreviations:

**Open-loop:** Sensorless control for induction motors

**RFC-A:** Asynchronous Rotor Flux Control for induction motors

**RFC-S:** Synchronous Rotor Flux Control for synchronous motors including permanent magnet motors.

### Default abbreviations:

Standard default value (50 Hz AC supply frequency)

USA default value (60 Hz AC supply frequency)

### NOTE

Parameter numbers shown in brackets {...} are the equivalent Menu 0 parameters. Some Menu 0 parameters appear twice since their function depends on the operating mode.

The Range - RFC-A / S column applies to both RFC-A and RFC-S. For some parameters, this column applies to only one of these modes, this is indicated accordingly in the Default columns.

In some cases, the function or range of a parameter is affected by the setting of another parameter. The information in the lists relates to the default condition of any parameters affected in this way.

**Table 10-2 Key to parameter table coding**

Coding	Attribute
<b>RW</b>	Read/Write: can be written by the user
<b>RO</b>	Read only: can only be read by the user
<b>Bit</b>	1 bit parameter. 'On' or 'Off' on the display
<b>Num</b>	Number: can be uni-polar or bi-polar
<b>Txt</b>	Text: the parameter uses text strings instead of numbers.
<b>Bin</b>	Binary parameter
<b>IP</b>	IP Address parameter
<b>Mac</b>	Mac Address parameter
<b>Date</b>	Date parameter
<b>Time</b>	Time parameter
<b>Chr</b>	Character parameter
<b>FI</b>	Filtered: some parameters which can have rapidly changing values are filtered when displayed on the drive keypad for easy viewing.
<b>DE</b>	Destination: This parameter selects the destination of an input or logic function.
<b>RA</b>	Rating dependent: this parameter is likely to have different values and ranges with drives of different voltage and current ratings. Parameters with this attribute will be transferred to the destination drive by non-volatile storage media when the rating of the destination drive is different from the source drive and the file is a parameter file. However, the values will be transferred if only the current rating is different and the file is a difference from default type file.
<b>ND</b>	No default: The parameter is not modified when defaults are loaded
<b>NC</b>	Not copied: not transferred to or from non-volatile media during copying.
<b>PT</b>	Protected: cannot be used as a destination.
<b>US</b>	User save: parameter saved in drive EEPROM when the user initiates a parameter save.
<b>PS</b>	Power-down save: parameter automatically saved in drive EEPROM when the under volts (UV) trip occurs.

**Table 10-3 Feature look-up table**

Feature	Related parameters (Pr)												
Acceleration rates	02.010	02.011 to 02.019		02.032	02.033	02.034	02.002						
Analog speed reference 1	01.036	07.010	07.001	07.007	07.008	07.009	07.025	07.026	07.030				
Analog speed reference 2	01.037	07.014	01.041	07.002	07.011	07.012	07.013	07.028	07.031				
Analog I/O	Menu 7												
Analog input 1	07.001	07.007	07.008	07.009	07.010	07.025	07.026	07.030					
Analog input 2	07.002	07.011	07.012	07.013	07.014	07.028	07.031						
Analog input 3	07.003	07.015	07.016	07.017	07.018	07.029	07.032						
Analog output 1	07.019	07.020	07.021	07.033									
Analog output 2	07.022	07.023	07.024										
Application menu	Menu 18			Menu 19		Menu 20							
At speed indicator bit	03.006	03.007	03.009	10.006	10.005	10.007							
Auto reset	10.034	10.035	10.036	10.001									
Autotune	05.012	05.016	05.017	05.023	05.024	05.025	05.010	05.029	05.030				
Binary sum	09.029	09.030	09.031	09.032	09.033	09.034							
Bipolar speed	01.010												
Brake control	12.040 to 12.049												
Braking	10.011	10.010	10.030	10.031	06.001	02.004	02.002	10.012	10.039	10.040			
Catch a spinning motor	06.009	05.040											
Coast to stop	06.001												
Comms	11.023 to 11.026												
Copying	11.042	11.036 to 11.040											
Cost - per kWh electricity	06.016	06.017	06.024	06.025	06.026	06.040							
Current controller	04.013	04.014											
Current feedback	04.001	04.002	04.017	04.004	04.012	04.020	04.023	04.024	04.026	10.008	10.009	10.017	
Current limits	04.005	04.006	04.007	04.018	04.015	04.019	04.016	05.007	05.010	10.008	10.009	10.017	
DC bus voltage	05.005	02.008											
DC injection braking	06.006	06.007	06.001										
Deceleration rates	02.020	02.021 to 02.029		02.004	02.035 to 02.037		02.002	02.008	06.001	10.030	10.031	10.039	02.009
Defaults	11.043	11.046											
Digital I/O	Menu 8												
Digital I/O read word	08.020												
Digital I/O T24	08.001	08.011	08.021	08.031									
Digital I/O T25	08.002	08.012	08.022	08.032									
Digital I/O T26	08.003	08.013	08.023	08.033									
Digital input T27	08.004	08.014	08.024										
Digital input T28	08.005	08.015	08.025	08.039									
Digital input T29	08.006	08.016	08.026	08.039									
Digital lock	13.010	13.001 to 13.009			13.011	13.012	13.016	03.022	03.023	13.019 to 13.023			
Digital output T22	08.008	08.018	08.028										
Direction	10.013	06.030	06.031	01.003	10.014	02.001	03.002	08.003	08.004	10.040			
Display timeout	11.041												
Drive active	10.002	10.040											
Drive derivative	11.028												
Drive OK	10.001	08.027	08.007	08.017	10.036	10.040							
Dynamic performance	05.026												
Dynamic V/F	05.013												
Electronic nameplate	03.049												
Enable	06.015	08.009	08.010										
Encoder reference	03.043	03.044	03.045	03.046									
Encoder set-up	03.033	03.034 to 03.042			03.047	03.048							
External trip	10.032	08.010	08.007										
Fan speed	06.045												
Fast disable	06.029												
Field weakening - induction motor	05.029	05.030	01.006	05.028									
Field weakening - servo	05.022	01.006	05.009										
Filter change	06.019	06.018											
Frequency reference selection	01.014	01.015											
Frequency slaving	03.001	03.013	03.014	03.015	03.016	03.017	03.018						
Hard speed reference	03.022	03.023											
Heavy duty rating	05.007	11.032											
High stability space vector modulation	05.019												

Feature	Related parameters (Pr)											
I/O sequencer	06.004	06.030	06.031	06.032	06.033	06.034	06.042	06.043	06.041			
Inertia compensation	02.038	05.012	04.022	03.018								
Jog reference	01.005	02.019	02.029									
Keypad reference	01.017	01.014	01.043	01.051	06.012	06.013						
Kt	05.032											
Limit switches	06.035	06.036										
Line power supply loss	06.003	10.015	10.016	05.005								
Local position reference	13.020 to 13.023											
Logic function 1	09.001	09.004	09.005	09.006	09.007	09.008	09.009	09.010				
Logic function 2	09.002	09.014	09.015	09.016	09.017	09.018	09.019	09.020				
Low voltage supply	06.044	06.046										
Marker pulse	03.032	03.031										
Maximum speed	01.006											
Menu 0 set-up	11.001 to 11.022			Menu 22								
Minimum speed	01.007	10.004										
Modules - number of	11.035											
Motor map	05.006	05.007	05.008	05.009	05.010	05.011						
Motor map 2	Menu 21		11.45									
Motorized potentiometer	09.021	09.022	09.023	09.024	09.025	09.026	09.027	09.028				
Offset speed reference	01.004	01.038	01.009									
Onboard PLC	11.047 to 11.051											
Open collector digital outputs	08.030											
Open loop vector mode	05.014	05.017	05.023									
Operating mode	00.048	11.031	03.024	05.014								
Orientation	13.010	13.013 to 13.015										
Output	05.001	05.002	05.003	05.004								
Overspeed threshold	03.008											
Phase angle	03.025	05.012										
PID controller	Menu 14											
Position feedback - drive	03.028	03.029	03.030	03.050								
Positive logic	08.029											
Power up parameter	11.022	11.021										
Precision reference	01.018	01.019	01.020	01.044								
Preset speeds	01.015	01.021 to 01.028			01.016	01.014	01.042	01.045 to 01.048			01.050	
Programmable logic	Menu 9											
Quasi square operation	05.020											
Ramp (accel / decel) mode	02.004	02.008	06.001	02.002	02.003	10.030	10.031	10.039				
Rated speed autotune	05.016	05.008										
Regenerating	10.010	10.011	10.030	10.031	06.001	02.004	02.002	10.012	10.039	10.040		
Relative jog	13.017 to 13.019											
Relay output	08.007	08.017	08.027									
Reset	10.033	08.002	08.022	10.034	10.035	10.036	10.001					
RFC mode (encoder less CLV mode)	03.024	03.042	04.012	05.040								
S ramp	02.006	02.007										
Sample rates	05.018											
SAFE TORQUE OFF input	08.009	08.010										
Security code	11.030	11.044										
Serial comms	11.023 to 11.026											
Skip speeds	01.029	01.030	01.031	01.032	01.033	01.034	01.035					
Slip compensation	05.027	05.008										
NV media card	11.036 to 11.040			11.042								
Firmware version	11.029	11.034										
Speed controller	03.010 to 03.017			03.019	03.020	03.021						
Speed feedback	03.002	03.003	03.004									
Speed feedback - drive	03.026	03.027	03.028	03.029	03.030	03.031	03.042					
Speed reference selection	01.014	01.015	01.049	01.050	01.001							
Status word	10.040											
Supply	06.044	05.005	06.046									
Switching frequency	05.018	05.035	07.034	07.035								
Thermal protection - drive	05.018	05.035	07.004	07.005	07.006	07.032	07.035	10.018				
Thermal protection - motor	04.015	05.007	04.019	04.016	04.025	07.015						
Thermistor input	07.003	07.015	07.046	07.047	07.048	07.049	07.050					
Threshold detector 1	12.001	12.003 to 12.007										
Threshold detector 2	12.002	12.023 to 12.027										

Feature	Related parameters (Pr)											
Time - filter change	06.019	06.018										
Time - powered up log	06.020	06.021	06.028									
Time - run log	06.022	06.023	06.028									
Torque	04.003	04.026	05.032									
Torque mode	04.008	04.011	04.009	04.010								
Trip detection	10.037	10.038	10.020 to 10.029									
Trip log	10.020 to 10.029			10.041 to 10.051			06.028	10.070 to 10.079				
Under voltage	05.005	10.016	10.015									
V/F mode	05.015	05.014										
Variable selector 1	12.008 to 12.015											
Variable selector 2	12.028 to 12.035											
Velocity feed forward	01.039	01.040										
Voltage controller	05.031											
Voltage mode	05.014	05.017	05.023	05.015								
Voltage rating	11.033	05.009	05.005									
Voltage supply	06.044	06.046	05.005									
Warning	10.019	10.012	10.017	10.018	10.040							
Zero speed indicator bit	03.005	10.003										

### Parameter ranges and Variable minimum/maximums:

Some parameters in the drive have a variable range with a variable minimum and a variable maximum values which is dependent on one of the following:

- The settings of other parameters
- The drive rating
- The drive mode
- Combination of any of the above

The tables below give the definition of variable minimum/maximum and the maximum range of these.

VM_AC_VOLTAGE		Range applied to parameters showing AC voltage
Units	V	
Range of [MIN]	0	
Range of [MAX]	0 to the value listed below	
Definition	VM_AC_VOLTAGE[MAX] is drive voltage rating dependent. See Table 10-4 VM_AC_VOLTAGE[MIN] = 0	

VM_AC_VOLTAGE_SET		Range applied to the AC voltage set-up parameters
Units	V	
Range of [MIN]	0	
Range of [MAX]	0 to the value listed below	
Definition	VM_AC_VOLTAGE[MAX] is drive voltage rating dependent. See Table 10-4 VM_AC_VOLTAGE[MIN] = 0	

<b>VM_ACCEL_RATE</b>		Maximum applied to the ramp rate parameters
<b>Units</b>	s / 100 Hz, s / 1000 rpm, s / 1000 mm/s	
<b>Range of [MIN]</b>	Open-loop: 0.0 RFC-A, RFC-S: 0.000	
<b>Range of [MAX]</b>	Open-loop: 0.0 to 3200.0 RFC-A, RFC-S: 0.000 to 3200.000	
<b>Definition</b>	<p>Open-loop mode            If <i>Ramp Rate Units</i> (02.039) = 0:            VM_ACCEL_RATE[MAX] = 3200.0            If <i>Ramp Rate Units</i> (02.039) = 1:            VM_ACCEL_RATE[MAX] = 3200.0 x Pr <b>01.006</b> / 100.0</p> <p>VM_ACCEL_RATE[MIN] = 0.0</p> <p>RFC-A, RFC-S modes            If <i>Ramp Rate Units</i> (02.039) = 0:            VM_ACCEL_RATE[MAX] = 3200.000            If <i>Ramp Rate Units</i> (02.039) = 1:            VM_ACCEL_RATE[MAX] = 3200.000 x Pr <b>01.006</b> / 1000.0</p> <p>VM_ACCEL_RATE[MIN] = 0.000</p> <p>If the second motor map is selected (Pr <b>11.045</b> = 1) Pr <b>21.001</b> is used instead of Pr <b>01.006</b>.</p>	

<b>VM_AMC_ROLL_OVER</b>		Range applied the position parameters in the advanced motion controller
<b>Units</b>	User units	
<b>Range of [MIN]</b>	0 or $-2^{31}$	
<b>Range of [MAX]</b>	0 or $-2^{31}-1$	
<b>Definition</b>	<p>VM_AMC_ROLL_OVER[MAX] = <math>2^{31}-1</math></p> <p>VM_AMC_ROLL_OVER[MIN] = <math>2^{31}</math></p>	

<b>VM_AMC_UNIPOLAR_ROLL_OVER</b>		Range applied the position parameters in the advanced motion controller that are restricted to positive values
<b>Units</b>	User units	
<b>Range of [MIN]</b>	0	
<b>Range of [MAX]</b>	0 to $2^{31}-1$	
<b>Definition</b>	<p>VM_AMC_UNIPOLAR_ROLL_OVER[MAX] = VM_AMC_ROLL_OVER[MAX]</p> <p>VM_AMC_UNIPOLAR_ROLL_OVER[MIN] = 0</p>	

<b>VM_DC_VOLTAGE</b>		Range applied to parameters showing DC voltage
<b>Units</b>	V	
<b>Range of [MIN]</b>	0	
<b>Range of [MAX]</b>	0 to the value listed below	
<b>Definition</b>	<p>VM_DC_VOLTAGE[MAX] is the full scale d.c. link voltage feedback (over voltage trip level) for the drive. This level is drive voltage rating dependent. See Table 10-4</p> <p>VM_DC_VOLTAGE[MIN] = 0</p>	

<b>VM_DC_VOLTAGE_SET</b>		Range applied to DC voltage reference parameters
<b>Units</b>	V	
<b>Range of [MIN]</b>	0	
<b>Range of [MAX]</b>	0 to the value listed below	
<b>Definition</b>	<p>VM_DC_VOLTAGE_SET[MAX] is drive voltage rating dependent. See Table 10-4</p> <p>VM_DC_VOLTAGE_SET[MIN] = 0</p>	

<b>VM_DRIVE_CURRENT</b>		Range applied to parameters showing current in A
<b>Units</b>	A	
<b>Range of [MIN]</b>	-99999.999 to 0.000	
<b>Range of [MAX]</b>	0.000 to 99999.999	
<b>Definition</b>	VM_DRIVE_CURRENT[MAX] is equivalent to the full scale (over current trip level) or Kc value for the drive and is given by <i>Full Scale Current Kc</i> (11.061).  VM_DRIVE_CURRENT[MIN] = - VM_DRIVE_CURRENT[MAX]	

<b>VM_DRIVE_CURRENT_UNIPOLAR</b>		Unipolar version of VM_DRIVE_CURRENT
<b>Units</b>	A	
<b>Range of [MIN]</b>	0.000	
<b>Range of [MAX]</b>	0.000 to 99999.999	
<b>Definition</b>	VM_DRIVE_CURRENT_UNIPOLAR[MAX] = VM_DRIVE_CURRENT[MAX]  VM_DRIVE_CURRENT_UNIPOLAR[MIN] = 0.000	

<b>VM_HIGH_DC_VOLTAGE</b>		Range applied to parameters showing high DC voltage
<b>Units</b>	V	
<b>Range of [MIN]</b>	0	
<b>Range of [MAX]</b>	0 to 1500	
<b>Definition</b>	VM_HIGH_DC_VOLTAGE[MAX] is the full scale d.c. link voltage feedback for the high d.c. link voltage measurement which can measure the voltage if it goes above the normal full scale value. This level is drive voltage rating dependent. See Table 10-4  VM_HIGH_DC_VOLTAGE[MIN] = 0	

<b>VM_LOW_UNDER_VOLTS</b>		Range applied the low under-voltage threshold
<b>Units</b>	V	
<b>Range of [MIN]</b>	24	
<b>Range of [MAX]</b>	24 to 1150	
<b>Definition</b>	If <i>Back-up Mode Enable</i> (06.068) = 0: VM_LOW_UNDER_VOLTS[MAX] = VM_STD_UNDER_VOLTS[MIN] If <i>Back-up Mode Enable</i> (06.068) = 1: VM_LOW_UNDER_VOLTS[MAX] = VM_STD_UNDER_VOLTS[MIN] / 1.1.  VM_LOW_UNDER_VOLTS[MIN] = 24.	

VM_MOTOR1_CURRENT_LIMIT VM_MOTOR2_CURRENT_LIMIT		Range applied to current limit parameters
<b>Units</b>	%	
<b>Range of [MIN]</b>	0.0	
<b>Range of [MAX]</b>	0.0 to 1000.0	
<b>Definition</b>	<p>VM_MOTOR1_CURRENT_LIMIT[MIN] = 0.0</p> <p><b>Open-loop</b>            VM_MOTOR1_CURRENT_LIMIT[MAX] = <math>(I_{Tlimit} / I_{Trated}) \times 100 \%</math>            Where:  <math>I_{Tlimit} = I_{MaxRef} \times \cos(\sin^{-1}(I_{Mrated} / I_{MaxRef}))</math>  <math>I_{Mrated} = Pr\ 05.007 \sin \phi</math>  <math>I_{Trated} = Pr\ 05.007 \times \cos \phi</math>  <math>\cos \phi = Pr\ 05.010</math>  <math>I_{MaxRef}</math> is 0.7 x Pr 11.061 when the motor rated current set in Pr 05.007 is less than or equal to Pr 11.032 (i.e. Heavy duty), otherwise it is the lower of 0.7 x Pr 11.061 or 1.1 x Pr 11.060 (i.e. Normal duty).</p> <p><b>RFC-A</b>            VM_MOTOR1_CURRENT_LIMIT[MAX] = <math>(I_{Tlimit} / I_{Trated}) \times 100 \%</math>            Where:  <math>I_{Tlimit} = I_{MaxRef} \times \cos(\sin^{-1}(I_{Mrated} / I_{MaxRef}))</math>  <math>I_{Mrated} = Pr\ 05.007 \times \cos \phi_1</math>  <math>I_{Trated} = Pr\ 05.007 \times \sin \phi_1</math>  <math>\phi_1 = \cos^{-1}(Pr\ 05.010) + \phi_2</math>. <math>\phi_1</math> is calculated during an autotune. See the variable minimum / maximum calculations in the <i>Parameter Reference Guide</i> for more information regarding <math>\phi_2</math>.  <math>I_{MaxRef}</math> is 0.9 x Pr 11.061 when the motor rated current set in Pr 05.007 is less than or equal to Pr 11.032 (i.e. Heavy duty), otherwise it is the lower of 0.9 x Pr 11.061 or 1.1 x Pr 11.060 (i.e. Normal duty).</p> <p><b>RFC-S and Regen</b>            VM_MOTOR1_CURRENT_LIMIT[MAX] = <math>(I_{MaxRef} / Pr\ 05.007) \times 100 \%</math>            Where:  <math>I_{MaxRef}</math> is 0.9 x Pr 11.061 when the motor rated current set in Pr 05.007 is less than or equal to Pr 11.032 (i.e. Heavy duty), otherwise it is the lower of 0.9 x Pr 11.061 or 1.1 x Pr 11.060 (i.e. Normal duty).</p> <p>For VM_MOTOR2_CURRENT_LIMIT[MAX] use Pr 21.007 instead of Pr 05.007 and Pr 21.010 instead of Pr 05.010.</p>	

VM_NEGATIVE_REF_CLAMP1 VM_NEGATIVE_REF_CLAMP2		Limits applied to the negative frequency or speed clamp																		
<b>Units</b>	Open-loop: Hz RFC-A, RFC-S: rpm or mm/s																			
<b>Range of [MIN]</b>	Open-loop: -3000.0 to 0.0 RFC-A, RFC-S: -50000.0 to 0.0																			
<b>Range of [MAX]</b>	Open-loop: 0.0 to 3000.0 RFC-A, RFC-S: 0.0 to 50000.0																			
<b>Definition</b>	<table border="1"> <thead> <tr> <th><i>Negative Reference Clamp Enable (01.008)</i></th> <th><i>Bipolar Reference Enable (01.010)</i></th> <th>VM_NEGATIVE_REF_CLAMP1[MIN]</th> <th>VM_NEGATIVE_REF_CLAMP1[MAX]</th> </tr> </thead> <tbody> <tr> <td>0</td> <td>0</td> <td>0.0</td> <td>Pr 01.006</td> </tr> <tr> <td>0</td> <td>1</td> <td>0.0</td> <td>0.0</td> </tr> <tr> <td>1</td> <td>X</td> <td>-VM_POSITIVE_REF_CLAMP1[MAX]</td> <td>0.0</td> </tr> </tbody> </table> <p>VM_NEGATIVE_REF_CLAMP2 is defined in the same way except that Pr 21.001 is used instead of Pr 01.006.</p>				<i>Negative Reference Clamp Enable (01.008)</i>	<i>Bipolar Reference Enable (01.010)</i>	VM_NEGATIVE_REF_CLAMP1[MIN]	VM_NEGATIVE_REF_CLAMP1[MAX]	0	0	0.0	Pr 01.006	0	1	0.0	0.0	1	X	-VM_POSITIVE_REF_CLAMP1[MAX]	0.0
<i>Negative Reference Clamp Enable (01.008)</i>	<i>Bipolar Reference Enable (01.010)</i>	VM_NEGATIVE_REF_CLAMP1[MIN]	VM_NEGATIVE_REF_CLAMP1[MAX]																	
0	0	0.0	Pr 01.006																	
0	1	0.0	0.0																	
1	X	-VM_POSITIVE_REF_CLAMP1[MAX]	0.0																	

<b>VM_POSITIVE_REF_CLAMP1</b> <b>VM_POSITIVE_REF_CLAMP2</b>		Limits applied to the positive frequency or speed reference clamp												
<b>Units</b>	Open-loop: Hz RFC-A, RFC-S: rpm or mm/s													
<b>Range of [MIN]</b>	Open-loop: 0.0 RFC-A, RFC-S: 0.0													
<b>Range of [MAX]</b>	Open-loop: 3000.0 RFC-A, RFC-S: 0.0 to 50000.0													
<b>Definition</b>	<p>VM_POSITIVE_REF_CLAMP1[MAX] defines the range of the positive reference clamp, <i>Maximum Reference Clamp</i> (01.006), which in turn limit the references. In RFC-A and RFC-S modes a limit is applied so that the position feedback does not exceed the speed where the drive can no longer interpret the feedback signal correctly as given in the table below. The limit is based on the position feedback device selected with <i>Motor Control Feedback Select</i> (03.026). It is possible to disable this limit if the <i>RFC Feedback Mode</i> (03.024) <math>\geq 1</math> (i.e. VM_POSITIVE_REF_CLAMP1 = 50000.0), so that the motor can be operated at a speed above the level where the drive can interpret the feedback in sensorless mode. It should be noted that the position feedback device itself may have a maximum speed limit that is lower than those given in the table. Care should be taken not to exceed a speed that would cause damage to the position feedback device.</p> <table border="1"> <thead> <tr> <th>Feedback device</th> <th>VM_POSITIVE_REF_CLAMP1[MAX]</th> </tr> </thead> <tbody> <tr> <td>AB, AB Servo</td> <td>(500 kHz x 60 / rotary lines per revolution) rpm (500 kHz / linear line pitch in mm) mm/s</td> </tr> <tr> <td>FD, FR, FD Servo, FR Servo</td> <td>(500 kHz x 60 / rotary lines per revolution)/2 rpm (500 kHz / linear line pitch in mm)/2 mm/s</td> </tr> <tr> <td>SC, SC Hiper, SC EnDat, SC SSI, SC Servo</td> <td>(500 kHz x 60 / sine waves per revolution) rpm (500 kHz / linear sine wave pitch in mm) mm/s</td> </tr> <tr> <td>Resolver</td> <td>(1000 Hz x 60 / resolver pole pairs) rpm (1000 Hz / pole pitch in mm / resolver pole pairs) mm/s</td> </tr> <tr> <td>Any other device</td> <td>50000.0 rpm or mm/s</td> </tr> </tbody> </table> <p>In open-loop mode VM_POSITIVE_REF_CLAMP1[MAX] is fixed at 3000.0 Hz In RFC mode a limit is applied to the speed reference of 1250 x 60 / Motor pole pairs. Therefore, with a 4 pole motor the limit for VM_POSITIVE_REF_CLAMP1[MAX] will be 16,500 rpm. VM_POSITIVE_REF_CLAMP1[MIN] = 0.0 VM_POSITIVE_REF_CLAMP2 is defined in the same way as VM_POSITIVE_REF_CLAMP1 except VM_POSITIVE_REF_CLAMP2[MAX] defines the range of the positive reference clamp, <i>M2 Maximum Reference Clamp</i> (21.001), which in turn limits the references.</p>		Feedback device	VM_POSITIVE_REF_CLAMP1[MAX]	AB, AB Servo	(500 kHz x 60 / rotary lines per revolution) rpm (500 kHz / linear line pitch in mm) mm/s	FD, FR, FD Servo, FR Servo	(500 kHz x 60 / rotary lines per revolution)/2 rpm (500 kHz / linear line pitch in mm)/2 mm/s	SC, SC Hiper, SC EnDat, SC SSI, SC Servo	(500 kHz x 60 / sine waves per revolution) rpm (500 kHz / linear sine wave pitch in mm) mm/s	Resolver	(1000 Hz x 60 / resolver pole pairs) rpm (1000 Hz / pole pitch in mm / resolver pole pairs) mm/s	Any other device	50000.0 rpm or mm/s
Feedback device	VM_POSITIVE_REF_CLAMP1[MAX]													
AB, AB Servo	(500 kHz x 60 / rotary lines per revolution) rpm (500 kHz / linear line pitch in mm) mm/s													
FD, FR, FD Servo, FR Servo	(500 kHz x 60 / rotary lines per revolution)/2 rpm (500 kHz / linear line pitch in mm)/2 mm/s													
SC, SC Hiper, SC EnDat, SC SSI, SC Servo	(500 kHz x 60 / sine waves per revolution) rpm (500 kHz / linear sine wave pitch in mm) mm/s													
Resolver	(1000 Hz x 60 / resolver pole pairs) rpm (1000 Hz / pole pitch in mm / resolver pole pairs) mm/s													
Any other device	50000.0 rpm or mm/s													

<b>VM_POWER</b>		Range applied to parameters that either set or display power
<b>Units</b>	kW	
<b>Range of [MIN]</b>	-99999.999 to 0.000	
<b>Range of [MAX]</b>	0.000 to 99999.999	
<b>Definition</b>	<p>VM_POWER[MAX] is rating dependent and is chosen to allow for the maximum power that can be output by the drive with maximum a.c. output voltage, at maximum controlled current and unity power factor.</p> <p><math>VM\_POWER[MAX] = \sqrt{3} \times VM\_AC\_VOLTAGE[MAX] \times VM\_DRIVE\_CURRENT[MAX] / 1000</math></p> <p>VM_POWER[MIN] = -VM_POWER[MAX]</p>	

<b>VM_RATED_CURRENT</b>		Range applied to rated current parameters
<b>Units</b>	A	
<b>Range of [MIN]</b>	-99999.999 to 0.000	
<b>Range of [MAX]</b>	0.000 to 99999.999	
<b>Definition</b>	<p>VM_RATED_CURRENT [MAX] = <i>Maximum Rated Current</i> (11.060) and is dependent on the drive rating. This is the Normal Duty rating of the drive.</p> <p>VM_RATED_CURRENT [MIN] = 0.00</p>	

<b>VM_REGEN_REACTIVE</b>		Range applied to the reactive current reference in Regen mode
<b>Units</b>	%	
<b>Range of [MIN]</b>	-1000.0 to 0.0	
<b>Range of [MAX]</b>	0.0 to 1000.0	
<b>Definition</b>	$VM\_REGEN\_REACTIVE[MAX] = (VM\_MOTOR1\_CURRENT\_LIMIT2 - ILimit2)$  where ILimit gives the highest level of the active current reference that can occur. This value is defined by the current limit values. If the current limits are all set to their maximum values (i.e. VM_MOTOR1_CURRENT_LIMIT) then there is no current capability left for the reactive current. However, if the current limits are reduced the resulting headroom can be used for the reactive current. ILimit is defined by a combination of all the current limits excluding any reduction of the current limit due to the motor thermal model.  $VM\_REGEN\_REACTIVE[MIN] = - VM\_REGEN\_REACTIVE[MAX]$	

<b>VM_SPEED</b>		Range applied to parameters showing speed
<b>Units</b>	Open-loop, RFC-A, RFC-S: rpm or mm/s	
<b>Range of [MIN]</b>	Open-loop, RFC-A, RFC-S: -50000.0 to 0.0	
<b>Range of [MAX]</b>	Open-loop, RFC-A, RFC-S: 0.0 to 50000.0	
<b>Definition</b>	This variable minimum/maximum defines the range of speed monitoring parameters. To allow headroom for overshoot the range is set to twice the range of the speed references.  $VM\_SPEED[MAX] = 2 \times VM\_SPEED\_FREQ\_REF[MAX]$  $VM\_SPEED[MIN] = 2 \times VM\_SPEED\_FREQ\_REF[MIN]$	

<b>VM_SPEED_FREQ_REF</b>		Range applied to the frequency or speed reference parameters
<b>Units</b>	Open-loop: Hz RFC-A, RFC-S: rpm or mm/s	
<b>Range of [MIN]</b>	Open-loop: -3000.0 to 0.0 RFC-A, RFC-S: -50000.0 to 0.0	
<b>Range of [MAX]</b>	Open-loop: 0.0 to 3000.0 RFC-A, RFC-S: 0.0 to 50000.0	
<b>Definition</b>	If Pr <b>01.008</b> = 0: $VM\_SPEED\_FREQ\_REF[MAX] = Pr\ 01.006$ If Pr <b>01.008</b> = 1: $VM\_SPEED\_FREQ\_REF[MAX] = Pr\ 01.006$ or $ Pr\ 01.007 $ , whichever is larger. If the second motor map is selected (Pr <b>11.045</b> = 1) Pr <b>21.001</b> is used instead of Pr <b>01.006</b> and Pr <b>21.002</b> instead of Pr <b>01.007</b> .  $VM\_SPEED\_FREQ\_REF[MIN] = -VM\_SPEED\_FREQ\_REF[MAX]$ .	

<b>VM_SPEED_FREQ_REF_UNIPOLAR</b>		Unipolar version of VM_SPEED_FREQ_REF
<b>Units</b>	Open-loop: Hz RFC-A, RFC-S: rpm or mm/s	
<b>Range of [MIN]</b>	Open-loop: 0.0 RFC-A, RFC-S: 0.0	
<b>Range of [MAX]</b>	Open-loop: 0.0 to 3000.0 RFC-A, RFC-S: 0.0 to 50000.0	
<b>Definition</b>	$VM\_SPEED\_FREQ\_REF\_UNIPOLAR[MAX] = VM\_SPEED\_FREQ\_REF[MAX]$  $VM\_SPEED\_FREQ\_REF\_UNIPOLAR[MIN] = 0.0$	

<b>VM_SPEED_FREQ_USER_REFS</b>		Range applied to some Menu 1 reference parameters	
<b>Units</b>	Open-loop: Hz RFC-A, RFC-S: rpm or mm/s		
<b>Range of [MIN]</b>	Open-loop: -3000.0 to 3000.0 RFC-A, RFC-S: -50000.0 to 50000.0		
<b>Range of [MAX]</b>	Open-loop: 0.0 to 3000.0 RFC-A, RFC-S: 0.0 to 50000.0		
<b>Definition</b>	VM_SPEED_FREQ_REF_UNIPOLAR[MAX] = VM_SPEED_FREQ_REF[MAX]		
	<i>Negative Reference Clamp Enable (01.008)</i>	<i>Bipolar Reference Enable (01.010)</i>	<b>VM_SPEED_FREQ_USER_REFS [MIN]</b>
	0	0	Pr 01.007
	0	1	-VM_SPEED_FREQ_REF[MAX]
	1	0	0.0
	1	1	-VM_SPEED_FREQ_REF[MAX]
If the second motor map is selected (Pr 11.045 = 1) Pr 21.002 is used instead of Pr 01.007.			

<b>VM_STD_UNDER_VOLTS</b>		Range applied to the standard under-voltage threshold	
<b>Units</b>	V		
<b>Range of [MIN]</b>	0 to 1150		
<b>Range of [MAX]</b>	0 to 1150		
<b>Definition</b>	VM_STD_UNDER_VOLTS[MAX] = VM_DC_VOLTAGE_SET / 1.1 VM_STD_UNDER_VOLTS[MIN] is voltage rating dependent. See Table 10-4		

<b>VM_SUPPLY_LOSS_LEVEL</b>		Range applied to the supply loss threshold	
<b>Units</b>	V		
<b>Range of [MIN]</b>	0 to 1150		
<b>Range of [MAX]</b>	0 to 1150		
<b>Definition</b>	VM_SUPPLY_LOSS_LEVEL[MAX] = VM_DC_VOLTAGE_SET[MAX] VM_SUPPLY_LOSS_LEVEL[MIN] is drive voltage rating dependent. See Table 10-4		

<b>VM_SWITCHING_FREQUENCY</b>		Range applied the switching frequency parameters	
<b>Units</b>			
<b>Range of [MIN]</b>	0		
<b>Range of [MAX]</b>	6		
<b>Definition</b>	VM_SWITCHING_FREQUENCY[MAX] = Power stage dependent VM_SWITCHING_FREQUENCY[MIN] = 0		

<b>VM_TORQUE_CURRENT</b>		Range applied to torque and torque producing current parameters	
<b>Units</b>	%		
<b>Range of [MIN]</b>	-1000.0 to 0.0		
<b>Range of [MAX]</b>	0.0 to 1000.0		
<b>Definition</b>	<i>Select Motor 2 Parameters (11.045)</i>	<b>VM_TORQUE_CURRENT [MAX]</b>	
	0	VM_MOTOR1_CURRENT_LIMIT[MAX]	
	1	VM_MOTOR2_CURRENT_LIMIT[MAX]	
	VM_TORQUE_CURRENT[MIN] = -VM_TORQUE_CURRENT[MAX]		

<b>VM_TORQUE_CURRENT_UNIPOLAR</b>		Unipolar version of VM_TORQUE_CURRENT
<b>Units</b>	%	
<b>Range of [MIN]</b>	0.0	
<b>Range of [MAX]</b>	0.0 to 1000.0	
<b>Definition</b>	VM_TORQUE_CURRENT_UNIPOLAR[MAX] = VM_TORQUE_CURRENT[MAX] VM_TORQUE_CURRENT_UNIPOLAR[MIN] = 0.0	

<b>VM_USER_CURRENT</b>		Range applied to torque reference and percentage load parameters with one decimal place
<b>Units</b>	%	
<b>Range of [MIN]</b>	-1000.0 to 0.0	
<b>Range of [MAX]</b>	0.0 to 1000.0	
<b>Definition</b>	VM_USER_CURRENT[MAX] = <i>User Current Maximum Scaling</i> (04.024) VM_USER_CURRENT[MIN] = -VM_USER_CURRENT[MAX]	

<b>VM_USER_CURRENT_HIGH_RES</b>		Range applied to torque reference and percentage load parameters with two decimal places
<b>Units</b>	%	
<b>Range of [MIN]</b>	-1000.00 to 0.00	
<b>Range of [MAX]</b>	0.0 to 1000.00	
<b>Definition</b>	VM_USER_CURRENT_HIGH_RES[MAX] = <i>User Current Maximum Scaling</i> (04.024) with an additional decimal place VM_USER_CURRENT_HIGH_RES[MIN] = -VM_USER_CURRENT_HIGH_RES[MAX]	

**Table 10-4 Voltage ratings dependant values**

Variable min/max	Voltage level (V)			
	200 V	400 V	575 V	690 V
VM_DC_VOLTAGE_SET[MAX]	400	800	955	1150
VM_DC_VOLTAGE[MAX]	415	830	990	1190
VM_AC_VOLTAGE_SET[MAX]	240	480	575	690
VM_AC_VOLTAGE[MAX]	325	650	780	930
VM_STD_UNDER_VOLTS[MIN]	175	330	435	435
VM_SUPPLY_LOSS_LEVEL[MIN]	205	410	540	540
VM_HIGH_DC_VOLTAGE	1500	1500	1500	1500



## 10.1 Menu 1: Frequency / speed reference

Figure 10-1 Menu 1 logic diagram

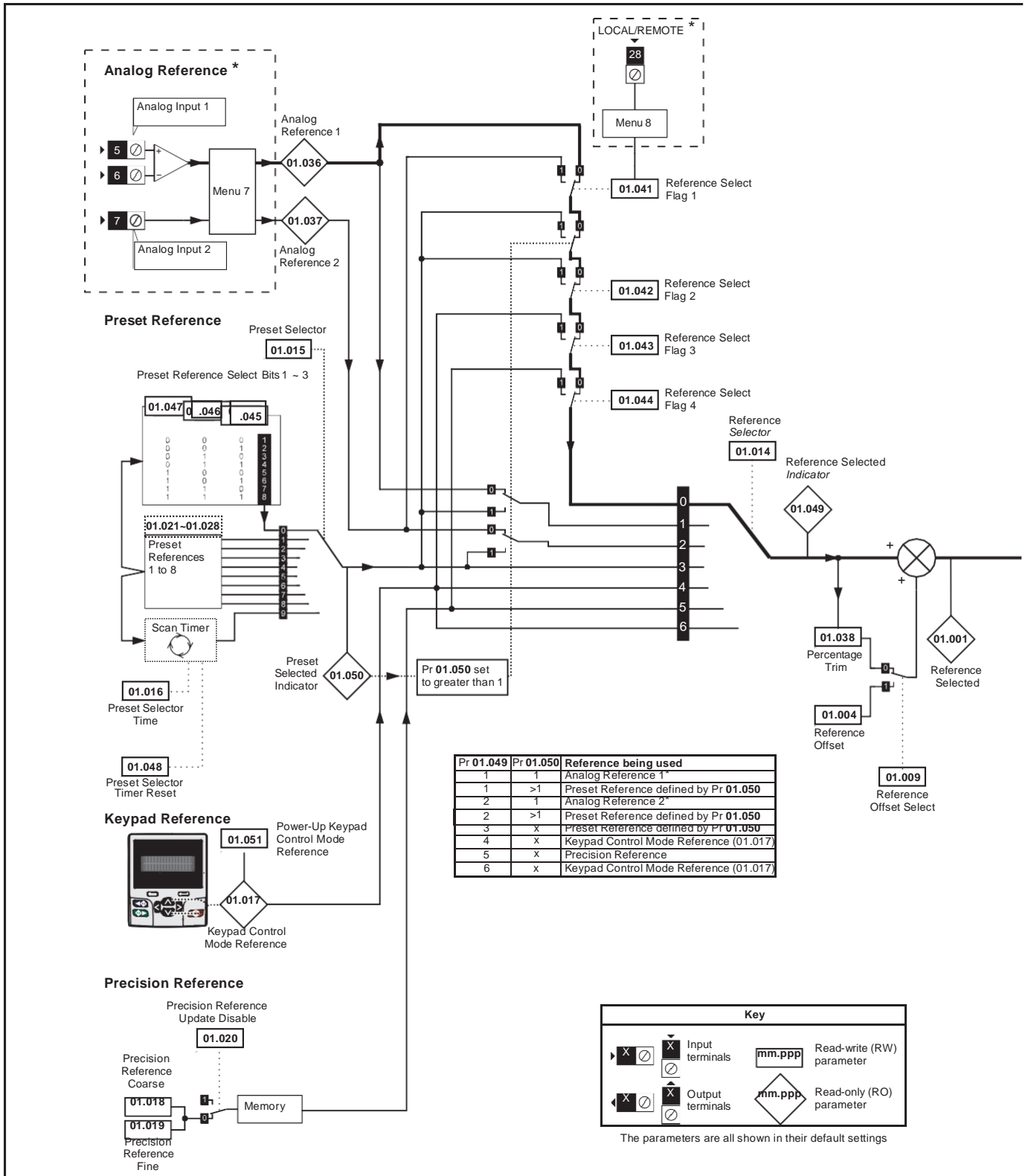

\* Not available on *Unidrive HS72*.

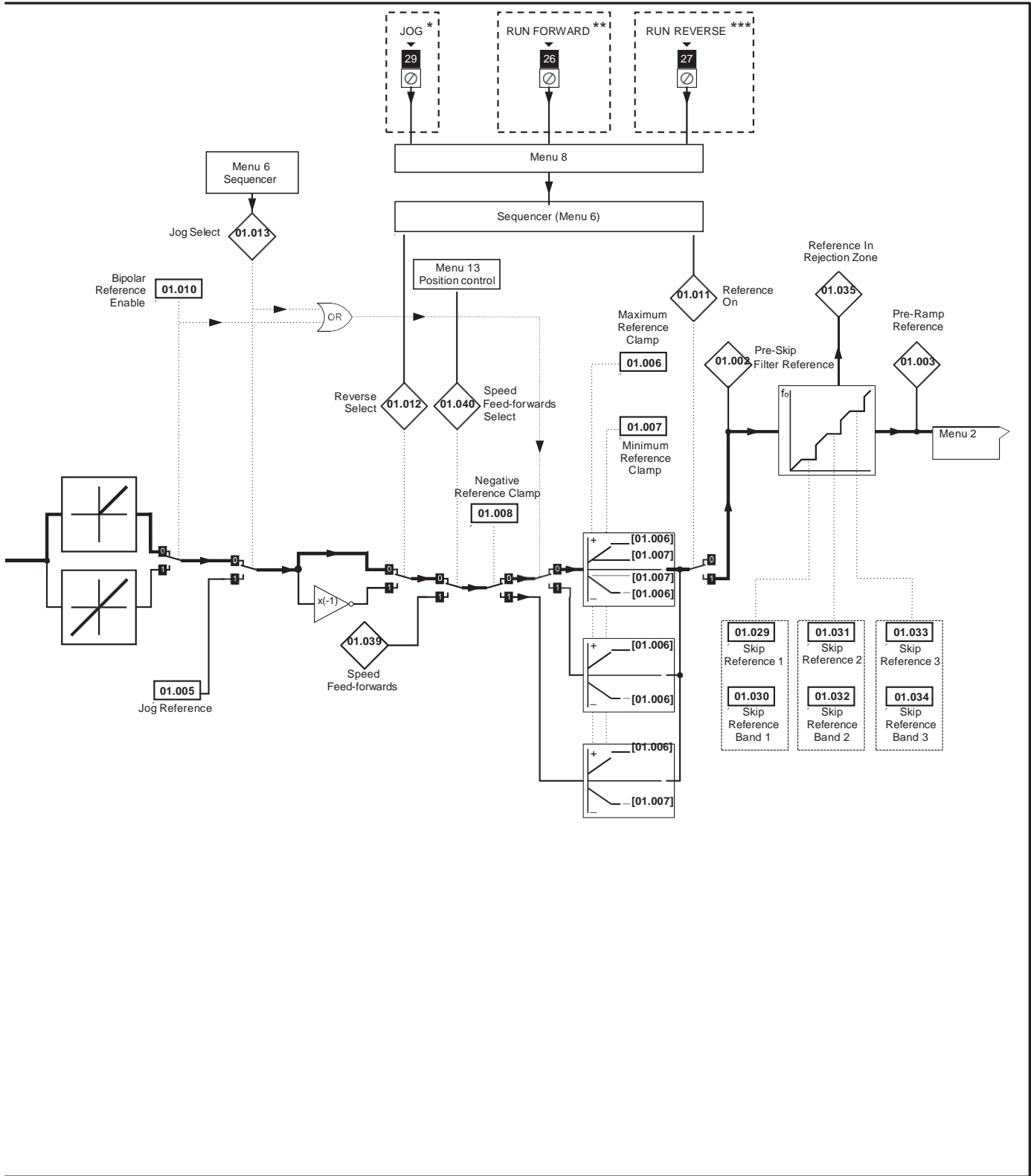

\* Not available on *Unidrive HS72*.  
 \*\* Terminal 7 on *Unidrive HS72*.  
 \*\*\* Terminal 8 on *Unidrive HS72*.

Parameter		Range(⇅)		Default(⇔)			Type					
		OL	RFC-A / S	OL	RFC-A	RFC-S	RO	Num	ND	NC	PT	
01.001	Reference Selected	±VM_SPEED_FREQ_REF Hz	±VM_SPEED_FREQ_REF rpm				RO	Num	ND	NC	PT	
01.002	Pre-Skip Filter Reference	±VM_SPEED_FREQ_REF Hz	±VM_SPEED_FREQ_REF rpm				RO	Num	ND	NC	PT	
01.003	Pre-Ramp Reference	±VM_SPEED_FREQ_REF Hz	±VM_SPEED_FREQ_REF rpm				RO	Num	ND	NC	PT	
01.004	Reference Offset	±VM_SPEED_FREQ_REF Hz	±VM_SPEED_FREQ_REF rpm	0.0			RW	Num				US
01.005	Jog Reference	0.0 - 400.0 Hz	0.0 - 4000.0 rpm	0.0			RW	Num				US
01.006	Maximum Reference Clamp	±VM_POSITIVE_REF_CLAMP1 Hz	±VM_POSITIVE_REF_CLAMP1 rpm	50 Hz: 50.0 60 Hz: 60.0	50Hz: 1500.0 60Hz: 1800.0	3000.0	RW	Num				US
01.007	Minimum Reference Clamp	±VM_NEGATIVE_REF_CLAMP1 Hz	±VM_NEGATIVE_REF_CLAMP1 rpm	0.0			RW	Num				US
01.008	Negative Reference Clamp	Off (0) or On (1)		Off (0)			RW	Bit				US
01.009	Reference Offset Select	Off (0) or On (1)		Off (0)			RW	Bit				US
01.010	Bipolar Reference Enable	Off (0) or On (1)		Off (0)			RW	Bit				US
01.011	Reference On	Off (0) or On (1)					RO	Bit	ND	NC	PT	
01.012	Reverse Select	Off (0) or On (1)					RO	Bit	ND	NC	PT	
01.013	Jog Select	Off (0) or On (1)					RO	Bit	ND	NC	PT	
01.014	Reference Selector	A1 A2 (0)*, A1 Preset (1)*, A2 Preset (2)* Preset (3), Keypad (4), Precision (5) Keypad Ref (6)		A1 A2 (0)**			RW	Txt	ND			US
01.015	Preset Selector	0 to 9		0			RW	Num				US
01.016	Preset Selector Time	0 to 400.0 s		10.0 s			RW	Num				US
01.017	Keypad Control Mode Reference	±VM_SPEED_FREQ_USER_REFS		0.0			RO	Num		NC	PT	PS
01.018	Precision Reference Coarse	±VM_SPEED_FREQ_REF		0.0			RW	Num				US
01.019	Precision Reference Fine	0.000 to 0.099 Hz	0.000 to 0.099 rpm	0.000			RW	Num				us
01.020	Precision Reference Update Disable	Off (0) or On (1)		Off (0)			RW	Bit		NC		
01.021	Preset Reference 1	±VM_SPEED_FREQ_REF		0.0			RW	Num				US
01.022	Preset Reference 2	±VM_SPEED_FREQ_REF		0.0			RW	Num				US
01.023	Preset Reference 3	±VM_SPEED_FREQ_REF		0.0			RW	Num				US
01.024	Preset Reference 4	±VM_SPEED_FREQ_REF		0.0			RW	Num				US
01.025	Preset Reference 5	±VM_SPEED_FREQ_REF		0.0			RW	Num				US
01.026	Preset Reference 6	±VM_SPEED_FREQ_REF		0.0			RW	Num				US
01.027	Preset Reference 7	±VM_SPEED_FREQ_REF		0.0			RW	Num				US
01.028	Preset Reference 8	±VM_SPEED_FREQ_REF		0.0			RW	Num				US
01.029	Skip Reference 1	0.0 to 3000.0 Hz	0 to 50,000 rpm	0.0	0		RW	Num				US
01.030	Skip Reference Band 1	0.0 to 25.0 Hz	0 to 250 rpm	0.0	0		RW	Num				US
01.031	Skip Reference Band 2	0.0 to 3000.0 Hz	0 to 50,000 rpm	0.0	0		RW	Num				US
01.032	Skip Reference Band 2	0.0 to 25.0 Hz	0 to 250 rpm	0.0	0		RW	Num				US
01.033	Skip Reference 3	0.0 to 3000.0 Hz	0 to 50,000 rpm	0.0	0		RW	Num				US
01.034	Skip Reference Band 3	0.0 to 25.0 Hz	0 to 250 rpm	0.0	0		RW	Num				US
01.035	Reference In Rejection Zone	Off (0) or On (1)		Off (0) or On (1)			RO	Bit	ND	NC	PT	
01.036	Analog Reference 1	±VM_SPEED_FREQ_USER_REFS Hz	±VM_SPEED_FREQ_USER_REFS rpm	0.0			RO	Num		NC		
01.037	Analog Reference 2	±VM_SPEED_FREQ_USER_REFS Hz		0.0			RO	Num		NC		
01.038	Percentage Trim	±100.00 %		0.00 %			RW	Num		NC		
01.039	Speed Feed-forwards	±VM_SPEED_FREQ_REF					RO	Num	ND	NC	PT	
01.040	Speed Feed-forwards Select	Off (0) or On (1)					RO	Bit	ND	NC	PT	
01.041	Reference Select Flag 1	Off (0) or On (1)		Off (0)			RW	Bit		NC		
01.042	Reference Select Flag 2	Off (0) or On (1)		Off (0)			RW	Bit		NC		
01.043	Reference Select Flag 3	Off (0) or On (1)		Off (0)			RW	Bit		NC		
01.044	Reference Select Flag 4	Off (0) or On (1)		Off (0)			RW	Bit		NC		
01.045	Preset Select Flag 1	Off (0) or On (1)		Off (0)			RW	Bit		NC		
01.046	Preset Select Flag 2	Off (0) or On (1)		Off (0)			RW	Bit		NC		
01.047	Preset Select Flag 3	Off (0) or On (1)		Off (0)			RW	Bit		NC		
01.048	Preset Selector Timer Reset	Off (0) or On (1)		Off (0)			RW	Bit		NC		
01.049	Reference Selected Indicator	1 to 6					RO	Num	ND	NC	PT	
01.050	Preset Selected Indicator	1 to 8					RO	Num	ND	NC	PT	
01.051	Power-up Keypad Control Mode Reference	Reset (0), Last (1), Preset (2)		Reset (0)			RW	Txt				US
01.052	Hand/Off/Auto Operating Mode	0 to 3		0			RW	Num				US
01.055	Linear Speed Select	Off (0) or On (1)		Off (0)			RW	Bit				US
01.056	Linear Speed Selected	Off (0) or On (1)					RW	Bit	ND	NC	PT	
01.057	Force Reference Direction	None (0), Forward (1), Reverse (2)		None (0)			RW	Txt				

\* Not available on Unidrive HS72.

\*\* Preset (3) on Unidrive HS72.

RW	Read / Write	RO	Read only	Num	Number parameter	Bit	Bit parameter	Txt	Text string	Bin	Binary parameter	FI	Filtered
ND	No default value	NC	Not copied	PT	Protected parameter	RA	Rating dependent	US	User save	PS	Power-down save	DE	Destination



## 10.2 Menu 2: Ramps

Figure 10-2 Menu 2 logic diagram

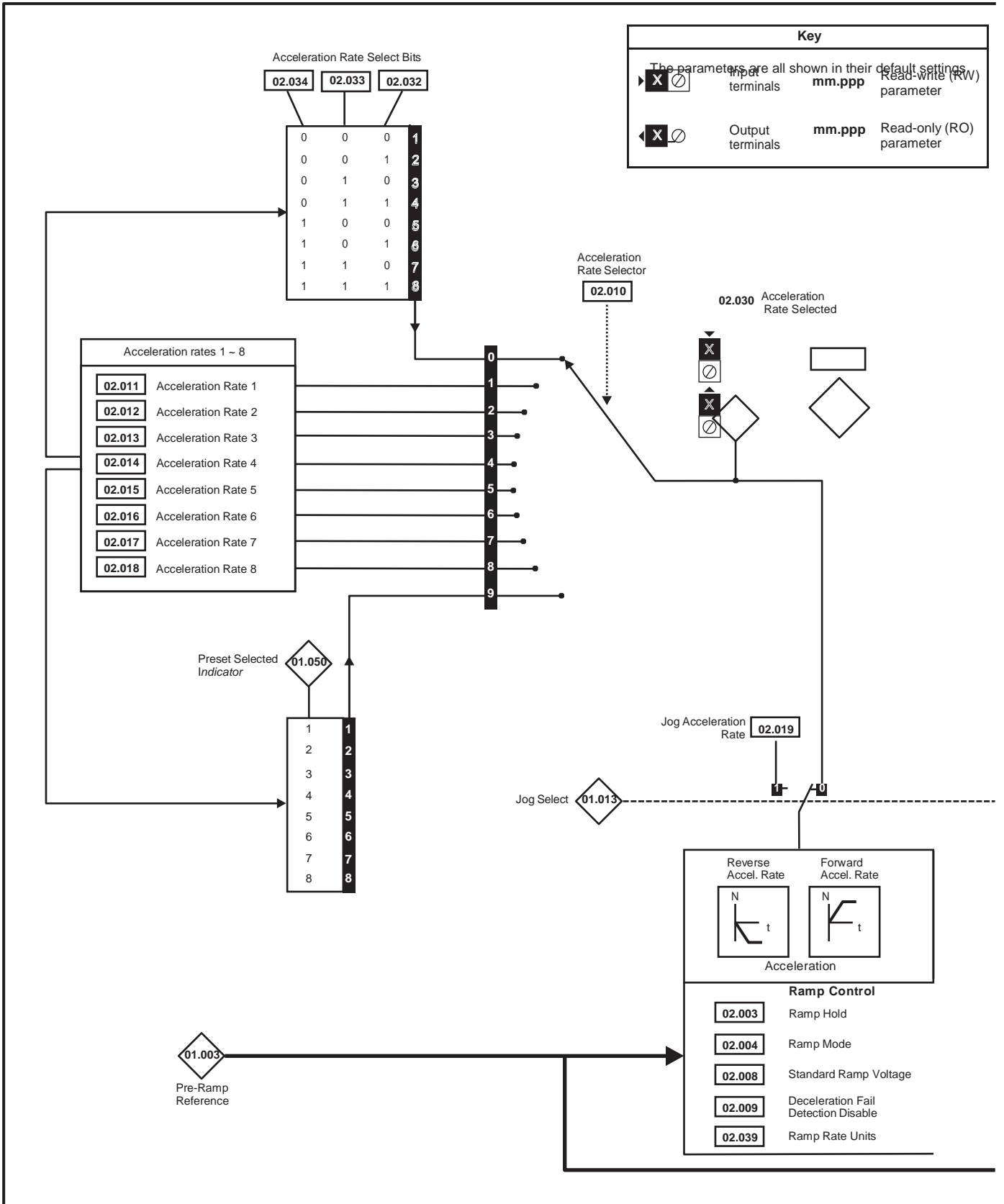

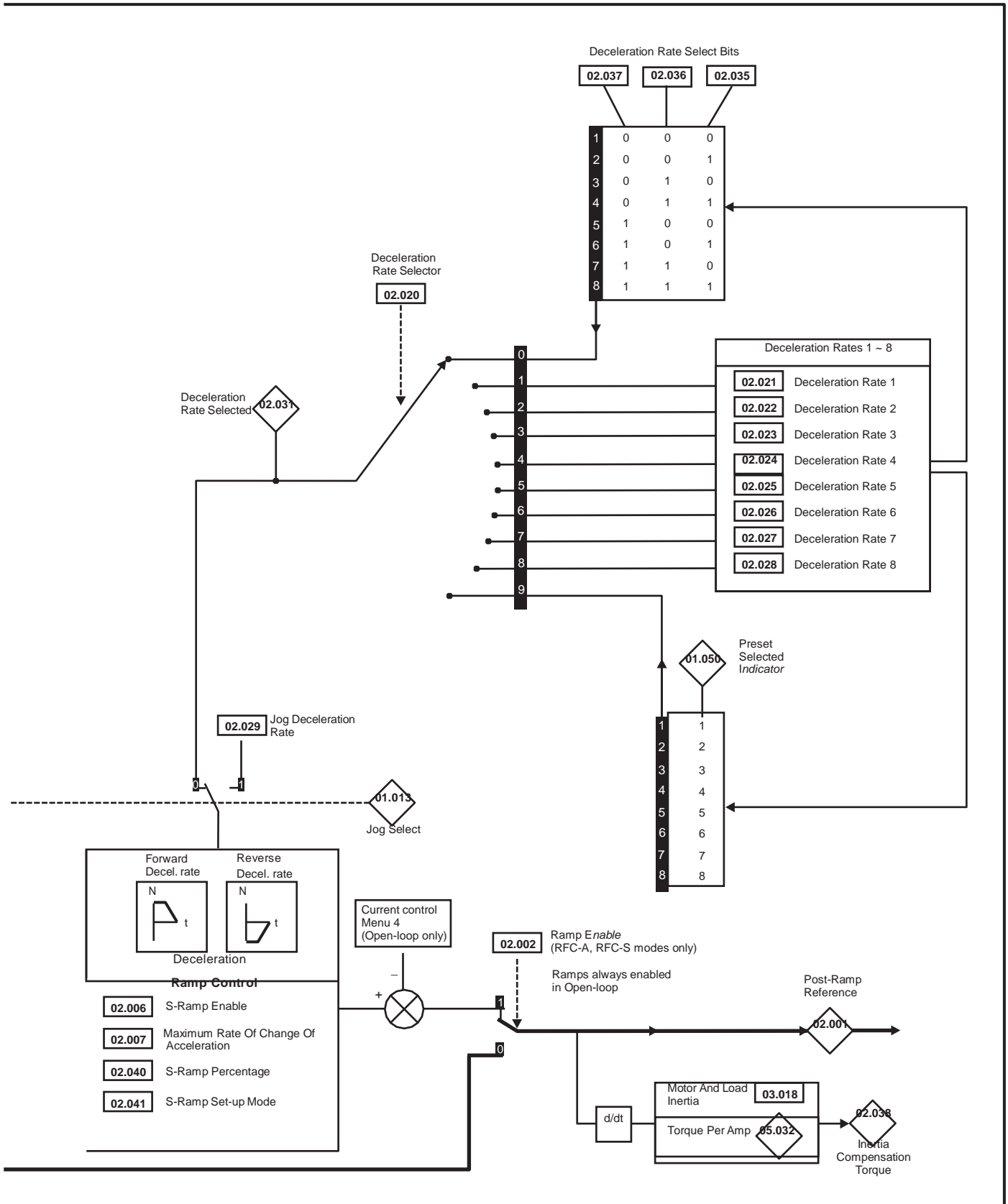

Parameter		Range(⇅)		Default(⇄)			Type					
		OL	RFC-A / S	OL	RFC-A	RFC-S						
02.001	Post Ramp Reference	±VM_SPEED_FREQ_REF Hz	±VM_SPEED_FREQ_REF rpm				RO	Num	ND	NC	PT	
02.002	Ramp Enable		Off (0) or On (1)			On (1)	RW	Bit				US
02.003	Ramp Hold		Off (0) or On (1)			Off (0)	RW	Bit				US
02.004	Ramp Mode	Fast (0), Standard (1), Std boost (2)	Fast (0), Standard (1)			Standard (1)	RW	Txt				US
02.005	Disable Ramp Output		Off (0) or On (1)			Off (0)	RW	Bit				US
02.006	S Ramp Enable		Off (0) or On (1)			Off (0)	RW	Bit				US
02.007	Maximum Rate Of Change Of Acceleration	0.0 to 300.0 s <sup>2</sup> /100 Hz	0.000 to 100.000 s <sup>2</sup> /1000 rpm	3.1	1.500	0.030	RW	Num				US
02.008	Standard Ramp Voltage	±VM_DC_VOLTAGE_SET V		200 V drive: 375 V 50 Hz - 400 V drive: 750 V 60 Hz - 400 V drive: 775 V 575 V drive: 895 V 690 V drive: 1075 V			RW	Num		RA		US
02.009	Deceleration Fail Detection Disable		Off (0) or On (1)			Off (0)	RW	Bit				US
02.010	Acceleration Rate Selector	0 to 9		0			RW	Num				US
02.011	Acceleration Rate 1	±VM_ACCEL_RATE s/100 Hz	±VM_ACCEL_RATE s/1000 rpm	5.0	2.000	0.200	RW	Num				US
02.012	Acceleration Rate 2	±VM_ACCEL_RATE s/100 Hz	±VM_ACCEL_RATE s/1000 rpm	5.0	2.000	0.200	RW	Num				US
02.013	Acceleration Rate 3	±VM_ACCEL_RATE s/100 Hz	±VM_ACCEL_RATE s/1000 rpm	5.0	2.000	0.200	RW	Num				US
02.014	Acceleration Rate 4	±VM_ACCEL_RATE s/100 Hz	±VM_ACCEL_RATE s/1000 rpm	5.0	2.000	0.200	RW	Num				US
02.015	Acceleration Rate 5	±VM_ACCEL_RATE s/100 Hz	±VM_ACCEL_RATE s/1000 rpm	5.0	2.000	0.200	RW	Num				US
02.016	Acceleration Rate 6	±VM_ACCEL_RATE s/100 Hz	±VM_ACCEL_RATE s/1000 rpm	5.0	2.000	0.200	RW	Num				US
02.017	Acceleration Rate 7	±VM_ACCEL_RATE s/100 Hz	±VM_ACCEL_RATE s/1000 rpm	5.0	2.000	0.200	RW	Num				US
02.018	Acceleration Rate 8	±VM_ACCEL_RATE s/100 Hz	±VM_ACCEL_RATE s/1000 rpm	5.0	2.000	0.200	RW	Num				US
02.019	Jog Acceleration Rate	±VM_ACCEL_RATE s/100 Hz	±VM_ACCEL_RATE s/1000 rpm	0.2	0.000		RW	Num				US
02.020	Deceleration Rate Selector	0 to 9		0			RW	Num				US
02.021	Deceleration Rate 1	±VM_ACCEL_RATE s/100 Hz	±VM_ACCEL_RATE s/1000 rpm	10.0	2.000	0.200	RW	Num				US
02.022	Deceleration Rate 2	±VM_ACCEL_RATE s/100 Hz	±VM_ACCEL_RATE s/1000 rpm	10.0	2.000	0.200	RW	Num				US
02.023	Deceleration Rate 3	±VM_ACCEL_RATE s/100 Hz	±VM_ACCEL_RATE s/1000 rpm	10.0	2.000	0.200	RW	Num				US
02.024	Deceleration Rate 4	±VM_ACCEL_RATE s/100 Hz	±VM_ACCEL_RATE s/1000 rpm	10.0	2.000	0.200	RW	Num				US
02.025	Deceleration Rate 5	±VM_ACCEL_RATE s/100 Hz	±VM_ACCEL_RATE s/1000 rpm	10.0	2.000	0.200	RW	Num				US
02.026	Deceleration Rate 6	±VM_ACCEL_RATE s/100 Hz	±VM_ACCEL_RATE s/1000 rpm	10.0	2.000	0.200	RW	Num				US
02.027	Deceleration Rate 7	±VM_ACCEL_RATE s/100 Hz	±VM_ACCEL_RATE s/1000 rpm	10.0	2.000	0.200	RW	Num				US
02.028	Deceleration Rate 8	±VM_ACCEL_RATE s/100 Hz	±VM_ACCEL_RATE s/1000 rpm	10.0	2.000	0.200	RW	Num				US
02.029	Jog Deceleration Rate	±VM_ACCEL_RATE s/100 Hz	±VM_ACCEL_RATE s/1000 rpm	0.2	0.000		RW	Num				US
02.030	Acceleration Rate Selected	0 to 8					RO	Num	ND	NC	PT	
02.031	Deceleration Rate Selected	0 to 8					RO	Num	ND	NC	PT	
02.032	Acceleration Rate Select Bit 0	Off (0) or On (1)		Off (0)			RW	Bit		NC		
02.033	Acceleration Rate Select Bit 1	Off (0) or On (1)		Off (0)			RW	Bit		NC		
02.034	Acceleration Rate Select Bit 2	Off (0) or On (1)		Off (0)			RW	Bit		NC		
02.035	Deceleration Rate Select Bit 0	Off (0) or On (1)		Off (0)			RW	Bit		NC		
02.036	Deceleration Rate Select Bit 1	Off (0) or On (1)		Off (0)			RW	Bit		NC		
02.037	Deceleration Rate Select Bit 2	Off (0) or On (1)		Off (0)			RW	Bit		NC		
02.038	Inertia Compensation Torque		±1000.0 %				RO	Num	ND	NC	PT	
02.039	Ramp Rate Units	Off (0) or On (1)		Off (0)			RW	Bit				US
02.040	S Ramp Percentage	0.0 to 50.0 %		0.0 %			RW					US
02.041	S Ramp Set-up Mode	0 to 2		0			RW	Num				US
02.042	Maximum Rate Of Change Of Acceleration 1	0.0 to 300.0	0.000 to 100.000	0.0	0.000		RW	Num				US
02.043	Maximum Rate Of Change Of Acceleration 2	0.0 to 300.0	0.000 to 100.000	0.0	0.000		RW	Num				US
02.044	Maximum Rate Of Change Of Acceleration 3	0.0 to 300.0	0.000 to 100.000	0.0	0.000		RW	Num				US
02.045	Maximum Rate Of Change Of Acceleration 4	0.0 to 300.0	0.000 to 100.000	0.0	0.000		RW	Num				US
02.050	Timing Options Select			0000 to 1111			RW	Bin				US
02.051	Timing Options Active			0000 to 1111			RO	Bin	ND	NC	PT	

RW	Read / Write	RO	Read only	Num	Number parameter	Bit	Bit parameter	Txt	Text string	Bin	Binary parameter	FI	Filtered
ND	No default value	NC	Not copied	PT	Protected parameter	RA	Rating dependent	US	User save	PS	Power-down save	DE	Destination

### 10.3 Menu 3: Frequency slaving, speed feedback and speed control

Figure 10-3 Menu 3 Open-loop logic diagram

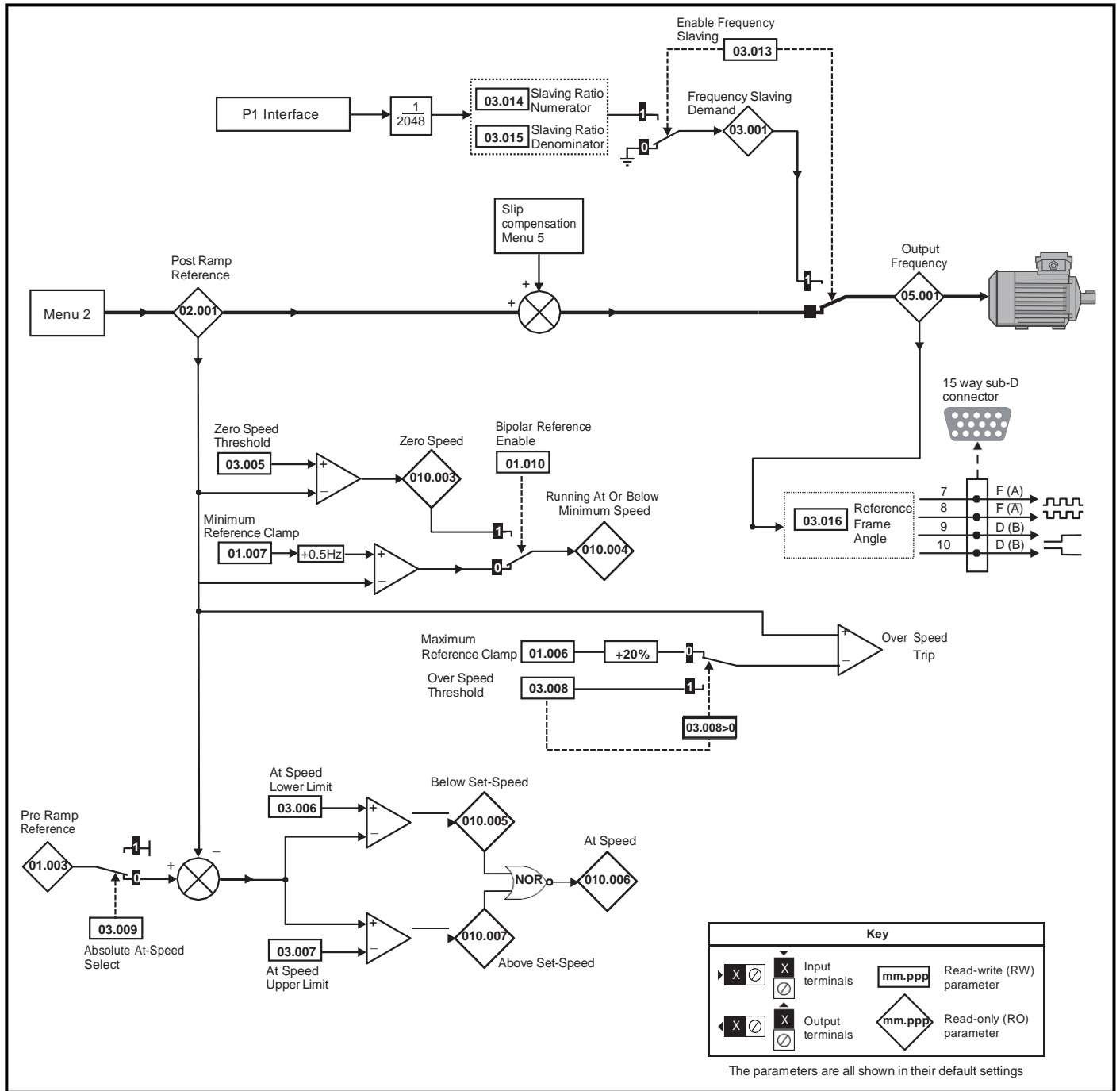
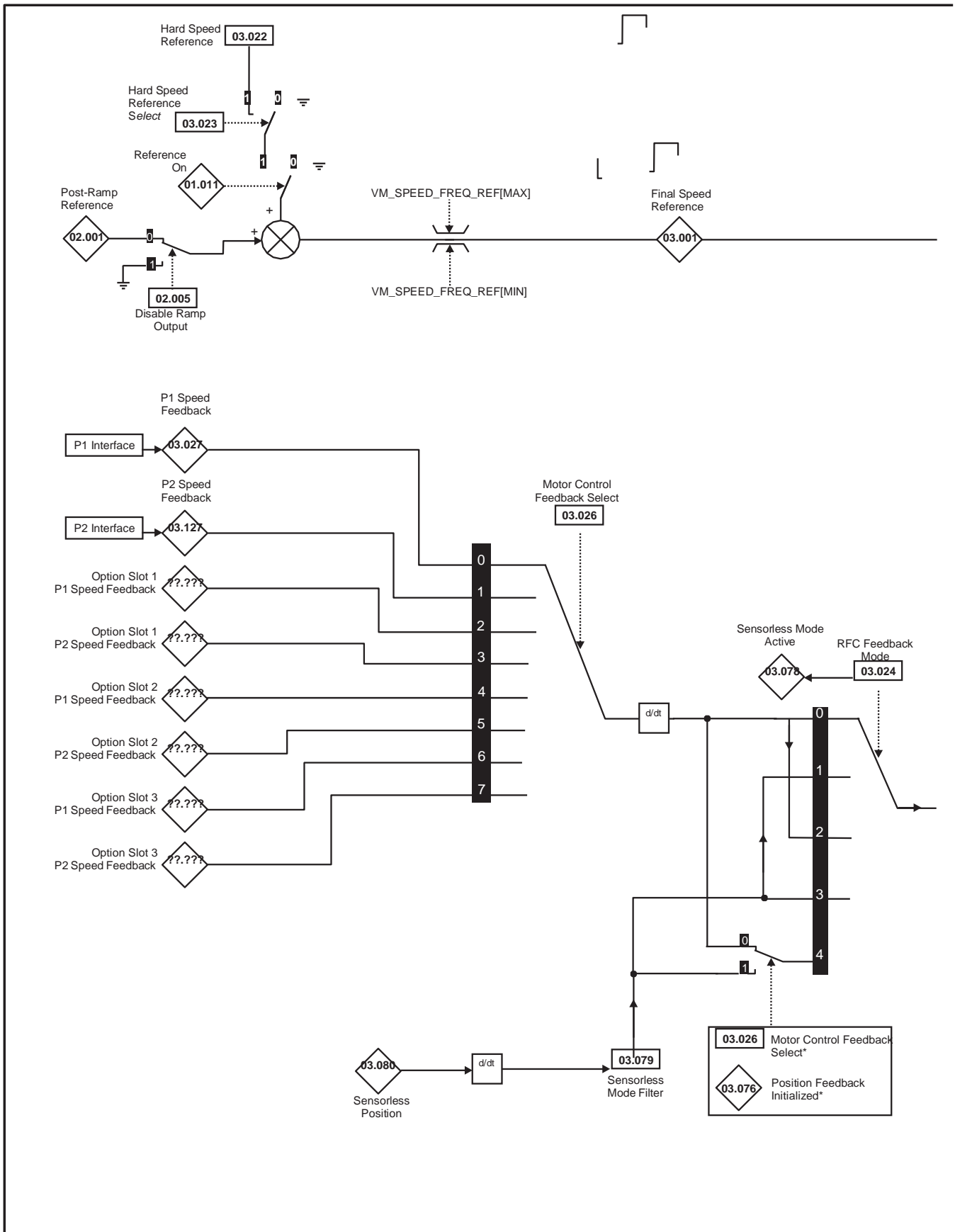

Figure 10-4 Menu 3 RFC-A, RFC-S logic diagram



**NOTE**

\* Automatic change over if the relevant 'bit' of *Position Feedback Initialized* (03.076) is 0.

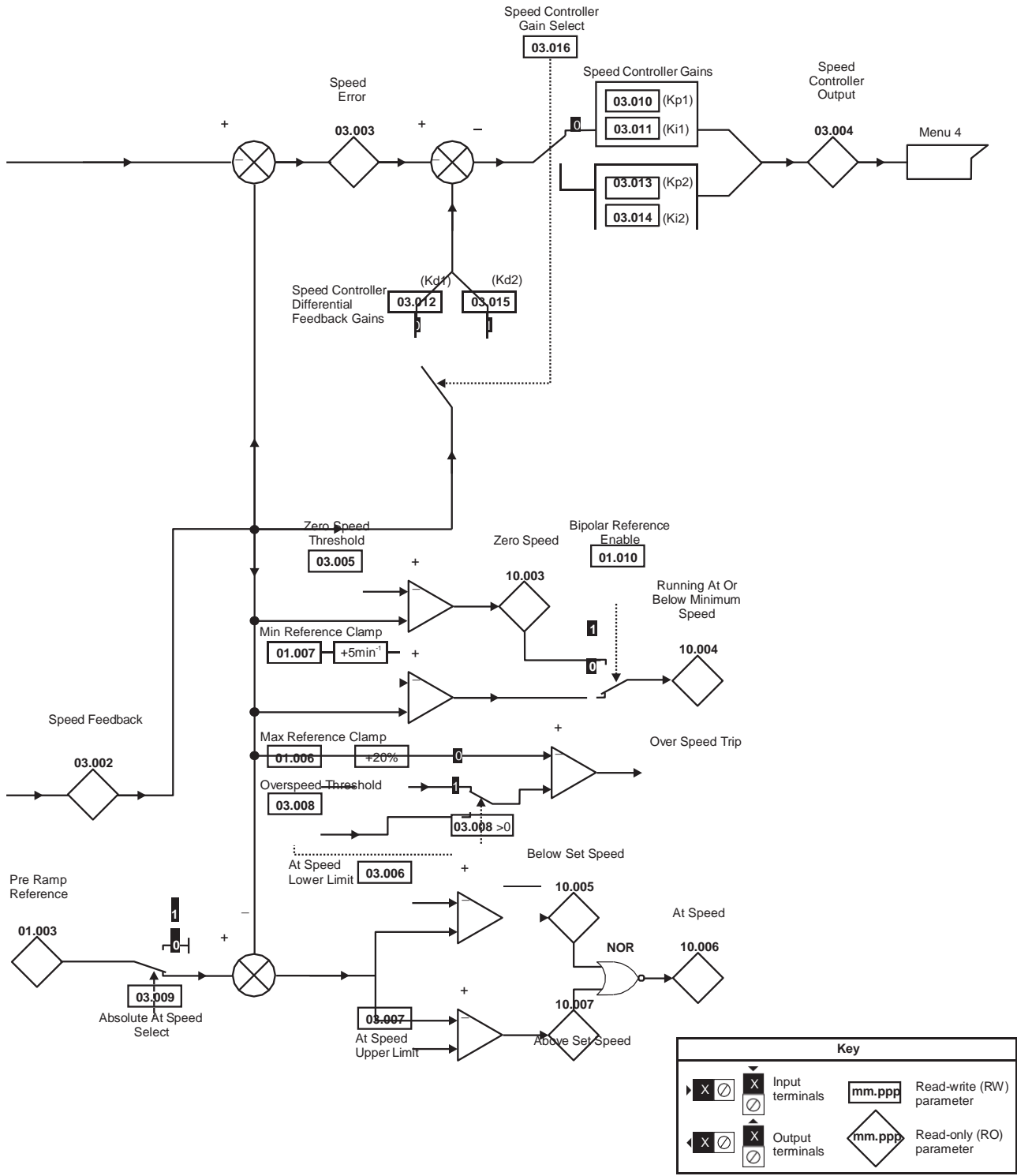

Figure 10-5 P1 Interface

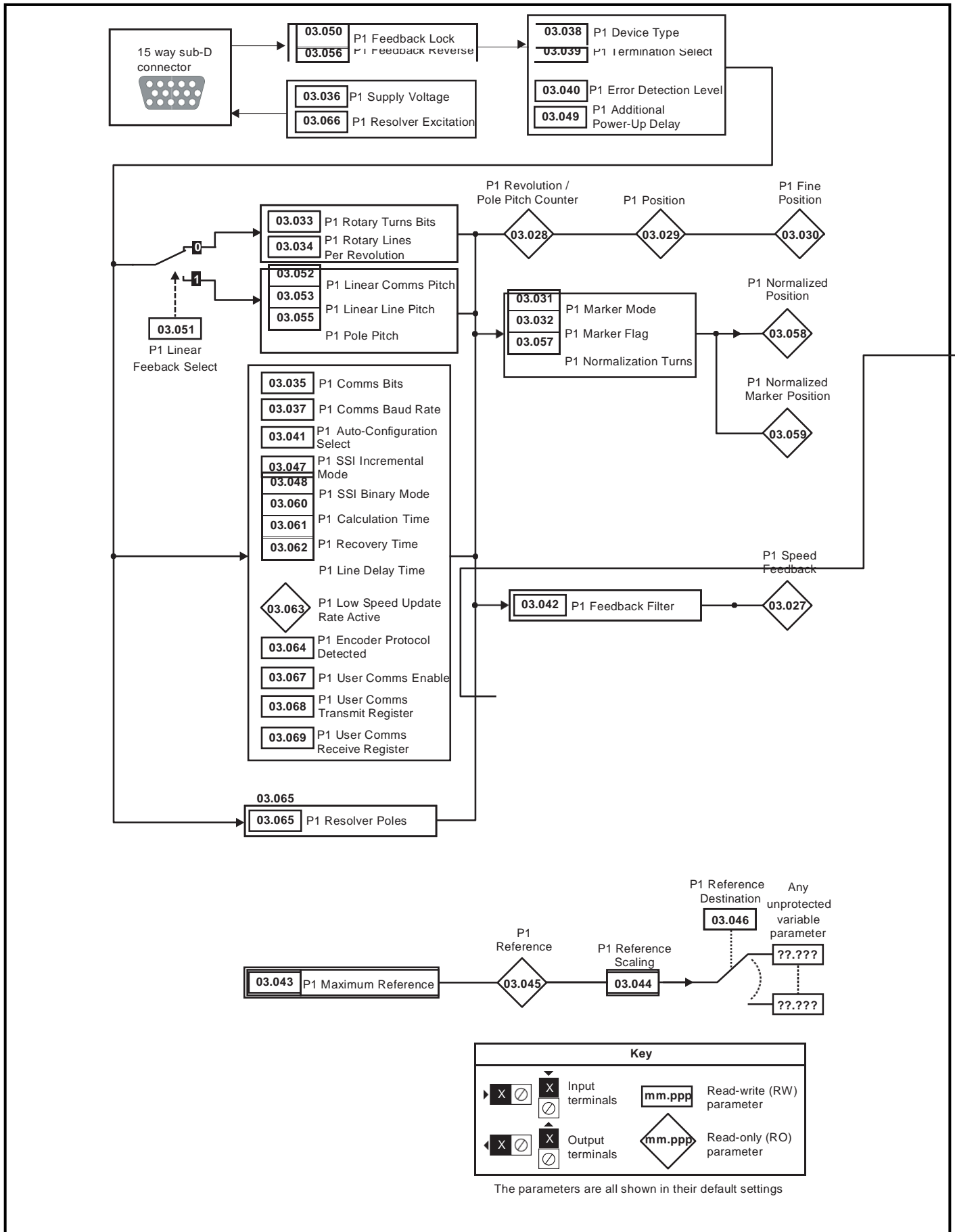
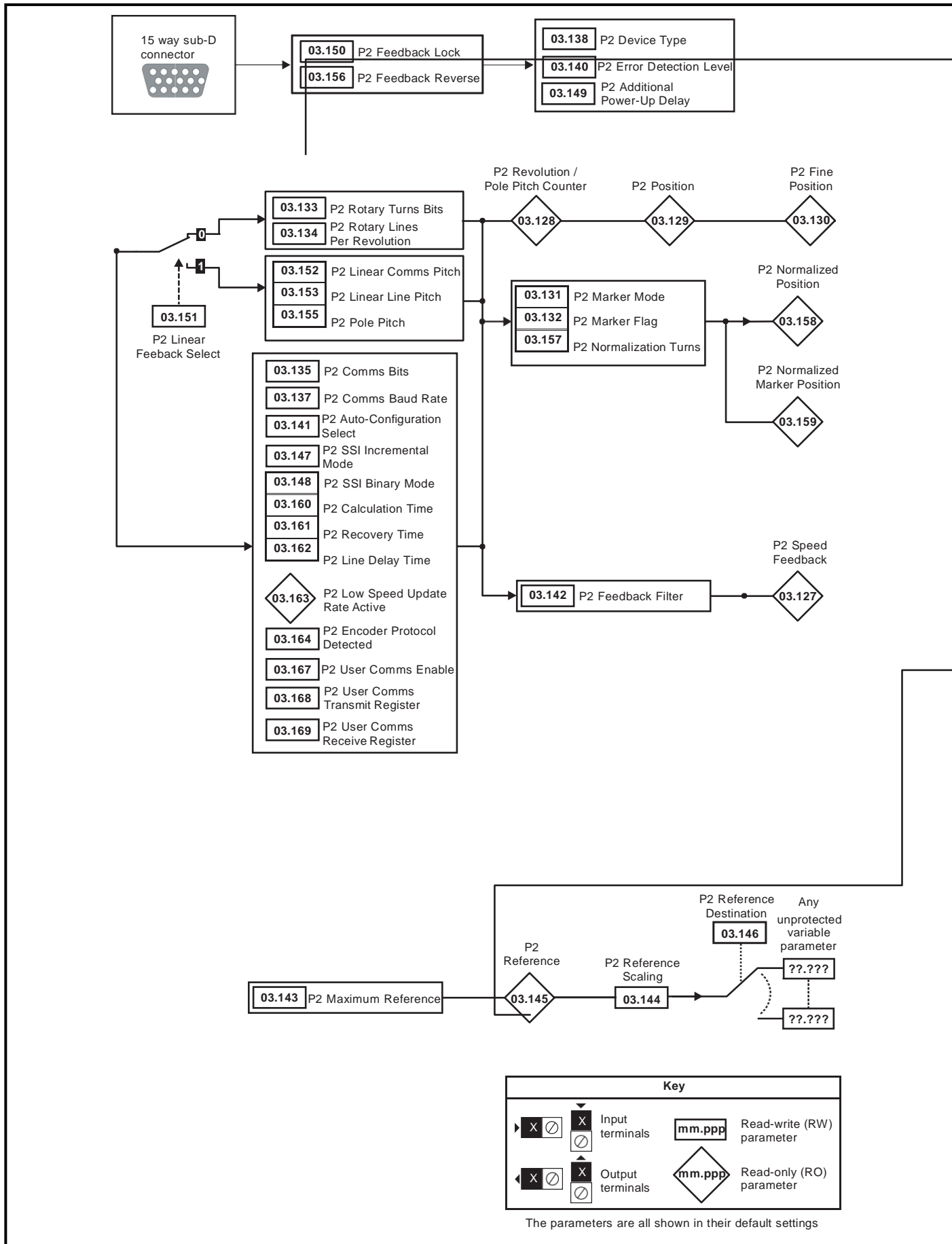
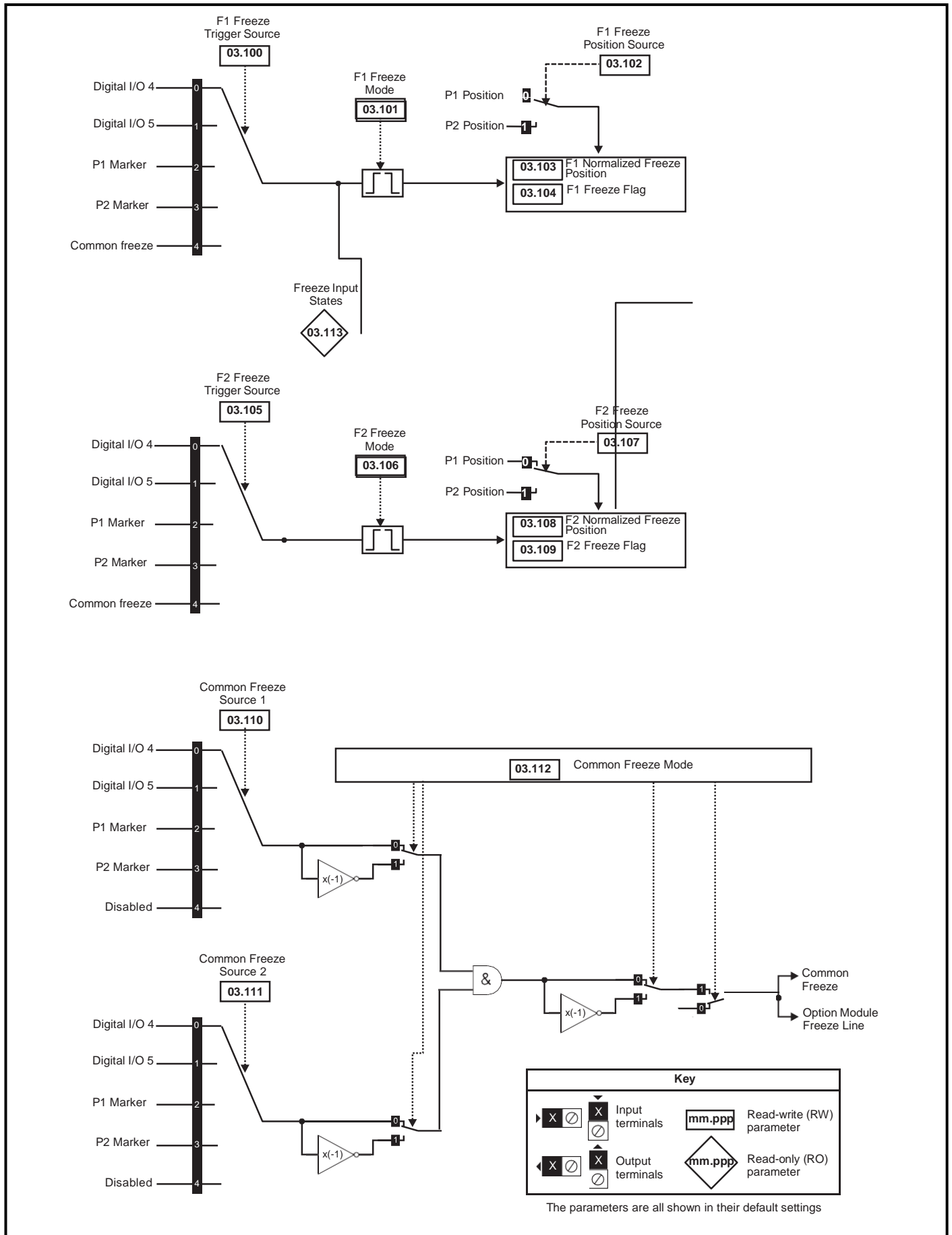

Figure 10-6 P2 Interface



**Figure 10-7 Freeze system logic**



**Figure 10-8 P1 Position feedback interface thermistor input**

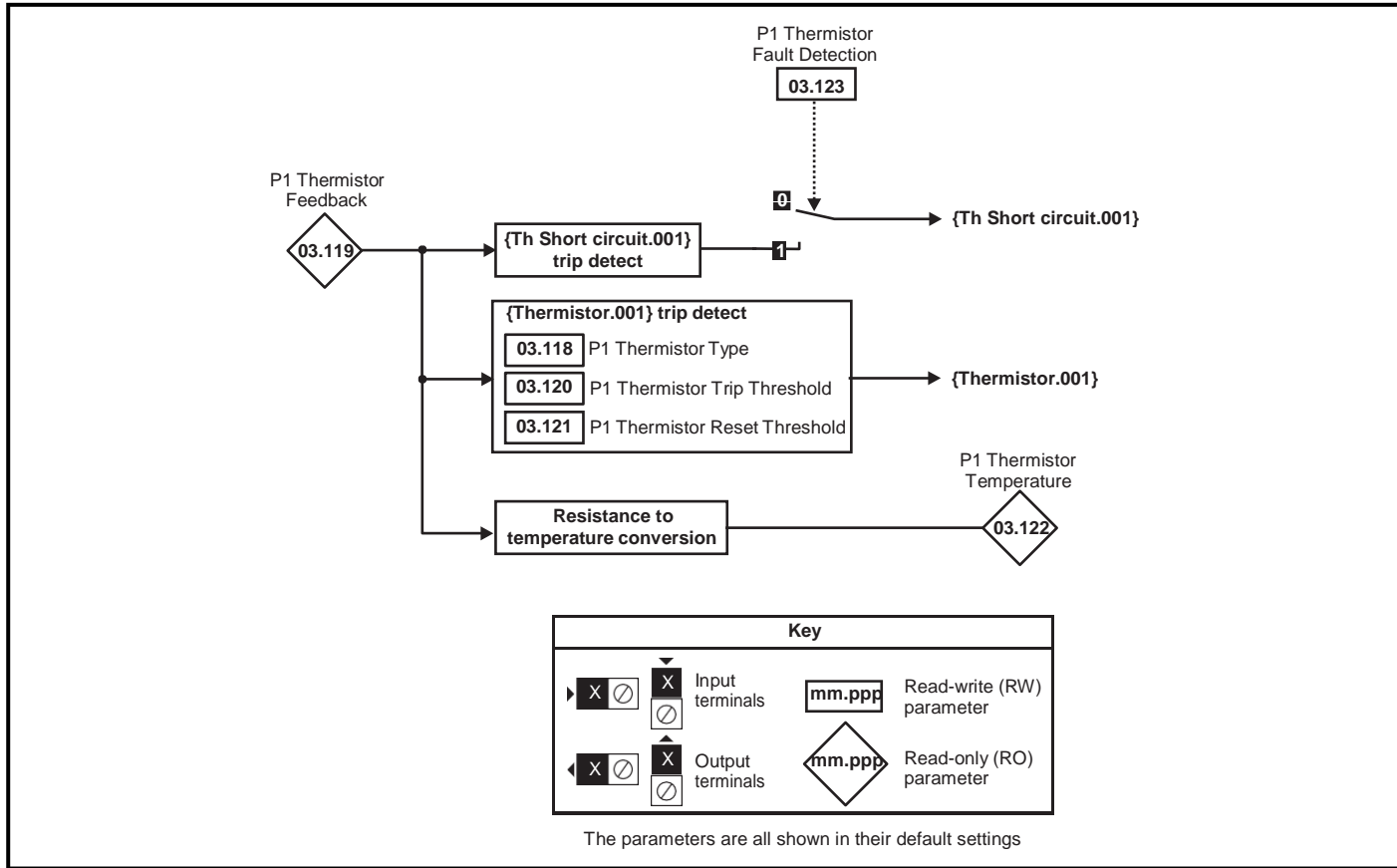

**Figure 10-9 Encoder simulation**

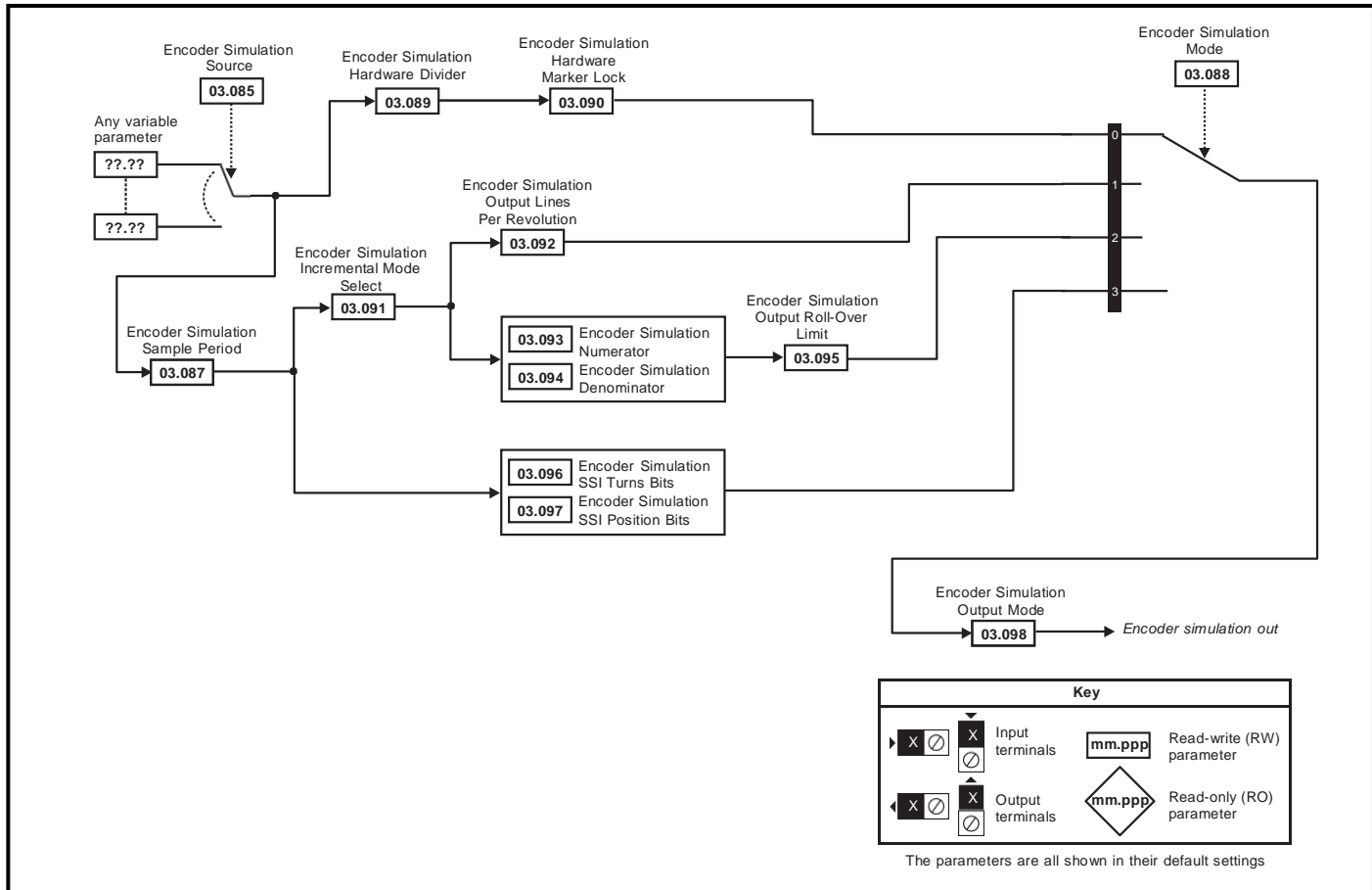

Parameter		Range			Default			Type					
		OL	RFC-A	RFC-S	OL	RFC-A	RFC-S	RO	Num	ND	NC	PT	FI
03.001	Open-loop> Frequency Slaving Demand	±1000.0 Hz						RO	Num	ND	NC	PT	FI
	RFC> Final Speed Reference		±VM_SPEED					RO	Num	ND	NC	PT	FI
03.002	Speed Feedback		±VM_SPEED					RO	Num	ND	NC	PT	FI
03.003	Speed Error		±VM_SPEED					RO	Num	ND	NC	PT	FI
03.004	Speed Controller Output		±VM_TORQUE_CURRENT %					RO	Num	ND	NC	PT	FI
03.005	Zero Speed Threshold	0.0 to 20.0 Hz	0 to 200 rpm		1.0 Hz	5 rpm		RW	Num				US
03.006	At Speed Lower Limit	0.0 to 3000.0 Hz	0 to 50,000 rpm		1.0 Hz	5 rpm		RW	Num				US
03.007	At Speed Upper Limit	0.0 to 3000.0 Hz	0 to 50,000 rpm		1.0 Hz	5 rpm		RW	Num				US
03.008	Over Speed Threshold	0.0 to 3000.0 Hz	0 to 50,000 rpm		0.0 Hz	0 rpm		RW	Num				US
03.009	Absolute At Speed Select		Off (0) or On (1)			Off (0)		RW	Bit				US
03.010	Speed Controller Proportional Gain Kp1		0.0000 to 200.0000 s/rad			0.0300 s/rad	0.0100 s/rad	RW	Num				US
03.011	Speed Controller Integral Gain Ki1		0.00 to 655.35 s <sup>2</sup> /rad			0.10 s <sup>2</sup> /rad	1.00 s <sup>2</sup> /rad	RW	Num				US
03.012	RFC> Speed Controller Differential Feedback Gain Kd1		0.00000 to 0.65535 1/rad			0.00000 1/rad		RW	Num				US
03.013	Open-loop> Enable Frequency Slaving	Off (0) or On (1)			Off (0)			RW	Bit				US
	RFC> Speed Controller Proportional Gain Kp2		0.0000 to 200.0000 s/rad			0.0300 s/rad	0.0100 s/rad	RW	Num				US
03.014	Open-loop> Slaving Ratio Numerator	0.000 to 1.000			1.000			RW	Num				US
	RFC> Speed Controller Integral Gain Ki2		0.00 to 655.35 s <sup>2</sup> /rad			0.10 s <sup>2</sup> /rad	1.00 s <sup>2</sup> /rad	RW	Num				US
03.015	Open-loop> Slaving Ratio Denominator	0.001 to 1.000			1.000			RW	Num				US
	RFC> Speed Controller Differential Feedback Gain Kd2		0.00000 to 0.65535 1/rad			0.00000 1/rad		RW	Num				US
03.016	Open-loop> Reference Frame Angle	0 to 65535						RO	Num	ND	NC	PT	
	RFC> Speed Controller Gain Select		Off (0) or On (1)			Off (0)		RW	Bit				US
03.017	Speed Controller Set-up Method		Disabled (0), Bandwidth (1), Comp Angle (2), Kp Gain Times 16 (3), Low Performance (4), Std Performance (5), High Performance (6), First Order (7)			Disabled (0)		RW	Txt				US
03.018	Motor And Load Inertia		0.00000 to 1000.00000 kgm <sup>2</sup>			0.00000 kgm <sup>2</sup>		RW	Num				US
03.019	Compliance Angle		0.0 to 360.0 °			4.0 °		RW	Num				US
03.020	Bandwidth		5 to 1000 Hz			10 Hz		RW	Num				US
03.021	Damping Factor		0.0 to 10.0			1.0		RW	Num				US
03.022	Hard Speed Reference		±VM_SPEED_FREQ_REF	±VM_SPEED		0.0		RW	Num				US
03.023	Hard Speed Reference Select		Off (0) or On (1)			Off (0)		RW	Bit				US
03.024	RFC Feedback Mode		Feedback (0), Sensorless (1), Feedback NoMax (2), Sensorless NoMax (3)			Feedback (0)		RW	Txt				US
03.025	Position Feedback Phase Angle			0.0 to 359.9 °				RW	Num	ND			US
03.026	Motor Control Feedback Select		P1 Drive (0), P2 Drive (1), P1 Slot 1 (2), P2 Slot 1 (3), P1 Slot 2 (4), P2 Slot 2 (5), P1 Slot 3 (6), P2 Slot 3 (7)			P1 Drive (0)		RW	Txt				US
03.027	P1 Speed Feedback		±VM_SPEED					RO	Num	ND	NC	PT	FI
03.028	P1 Revolution/Pole Pitch Counter		0 to 65535					RO	Num	ND	NC	PT	
03.029	P1 Position		0 to 65535					RO	Num	ND	NC	PT	
03.030	P1 Fine Position		0 to 65535					RO	Num	ND	NC	PT	
03.031	P1 Marker Mode		0000 to 1111			0100		RW	Bin				US
03.032	P1 Marker Flag		Off (0) or On (1)			Off (0)		RW	Bit		NC		
03.033	P1 Rotary Turns Bits		0 to 16			16		RW	Num				US
03.034	P1 Rotary Lines Per Revolution		1 to 100000			1024	4096	RW	Num				US
03.035	P1 Comms Bits		0 to 48			0		RW	Num				US
03.036	P1 Supply Voltage		5V (0), 8V (1), 15V (2)			5V (0)		RW	Txt				US
03.037	P1 Comms Baud Rate		100K (0), 200K (1), 300K (2), 400K (3), 500K (4), 1M (5), 1.5M (6), 2M (7), 4M (8)			300K (2)		RW	Txt				US

Parameter	Range			Default			Type						
	OL	RFC-A	RFC-S	OL	RFC-A	RFC-S							
03.038	P1 Device Type	AB (0), FD (1), FR (2), AB Servo (3), FD Servo (4), FR Servo (5), SC (6), SC Hiperface (7), EnDat (8), SC EnDat (9), SSI (10), SC SSI (11), SC Servo (12), BiSS (13), Resolver (14), SC SC (15), Commutation Only (16)			AB (0)		AB Servo (3)	RW	Txt				US
03.039	P1 Termination Select	0 to 2			1			RW	Num				US
03.040	P1 Error Detection Level	0000 to 1111			0000	0001		RW	Bin				US
03.041	P1 Auto-configuration Select	Disabled (0) or Enabled (1)			Enabled (1)			RW	Txt				US
03.042	P1 Feedback Filter	Disabled (0), 1 (1), 2 (2), 4 (3), 8 (4), 16 (5) ms			Disabled (0)			RW	Txt				US
03.043	P1 Maximum Reference	0 to 50,000 rpm			1500 rpm		3000 rpm	RW	Num				US
03.044	P1 Reference Scaling	0.000 to 4.000			1.000			RW	Num				US
03.045	P1 Reference	±100.0 %						RO	Num	ND	NC	PT	FI
03.046	P1 Reference destination	0.000 to 59.999			0.000			RW	Num	DE		PT	US
03.047	P1 SSI Incremental Mode	Off (0) or On (1)			Off (0)			RW	Bit				US
03.048	P1 SSI Binary Mode	Off (0) or On (1)			Off (0)			RW	Bit				US
03.049	P1 Additional Power-up Delay	0.0 to 25.0 s			0.0 s			RW	Num				US
03.050	P1 Feedback Lock	Off (0) or On (1)			Off (0)			RW	Bit				US
03.051	P1 Linear Feedback Select	Off (0) or On (1)			Off (0)			RW	Bit				US
03.052	P1 Linear Comms Pitch	0.001 to 100.000			0.001			RW	Num				US
03.053	P1 Linear Line Pitch	0.001 to 100.000			0.001			RW	Num				US
03.054	P1 Linear Comms And Line Pitch Units	millimetres (0) or micrometres (1)			millimetres (0)			RW	Txt				US
03.055	P1 Pole Pitch	0.01 to 1000.00 mm			10.00 mm			RW	Num				US
03.056	P1 Feedback Reverse	Off (0) or On (1)			Off (0)			RW	Bit				US
03.057	P1 Normalization Turns	0 to 16			16			RO	Num				US
03.058	P1 Normalized Position	-2147483648 to 2147483647						RO	Num	ND	NC	PT	
03.059	P1 Normalized Marker Position	-2147483648 to 2147483647						RO	Num	ND	NC	PT	
03.060	P1 Calculation Time	0 to 20 µs			5 µs			RW	Num				US
03.061	P1 Recovery Time	5 to 100 µs			30 µs			RW	Num				US
03.062	P1 Line Delay Time	0 to 5000 ns						RW	Num	ND	NC	PT	US
03.063	P1 Low Speed Update Rate Active	Off (0) or On (1)						RO	Bit	ND	NC	PT	
03.064	P1 Encoder Protocol Detected	None (0), Hiperface (1), EnDat 2.1 (2), EnDat 2.2 (3), BiSS (4)						RW	Txt	ND	NC	PT	
03.065	P1 Resolver Poles	2 Poles (1) to 20 Poles (10)			2 Pole (1)			RW	Txt				US
03.066	P1 Resolver Excitation	6kHz 3V (0), 8kHz 3V (1), 6kHz 2V (2), 8kHz 2V (3)			6kHz (0)			RW	Txt				US
03.067	P1 User Comms Enable	0 to 1			0			RW	Num				US
03.068	P1 User Comms Transmit Register	0 to 65535			0			RW	Num		NC	PT	
03.069	P1 User Comms Receive register	0 to 65535			0			RW	Num		NC	PT	
03.070	P1 Position Feedback Signals	000000 to 111111						RO	Num	ND	NC	PT	
03.071	P1 Error Detected	Off (0) or On (1)						RW	Bit	ND	NC	PT	
03.075	Initialise Position Feedback	Off (0) or On (1)			Off (0)			RW	Bit		NC		
03.076	Position Feedback Initialized	0000000000 to 1111111111			0000000000			RO	Bin		NC	PT	
03.078	Sensorless Mode Active	Off (0) or On (1)						RO	Bit	ND	NC	PT	
03.079	Sensorless Mode Filter	4 (0), 8 (1), 16 (2), 32 (3), 64 (4) ms			4 (0) ms			RW	Txt				US
03.080	Sensorless Position	-2147483648 to 2147483647						RO	Num	ND	NC	PT	
03.083	Full Motor Object Nameplate Transfer	Off (0) or On (1)			Off (0)			RW	Bit				US
03.085	Encoder Simulation Source	0.000 to 59.999			3.016	0.000		RW	Num			PT	US
03.086	Encoder Simulation Status	None (0), Full (1), No Marker Pulse (2)						RO	Txt	ND	NC	PT	
03.087	Encoder Simulation Sample Period	0.25 (0), 1 (1), 4 (2), 16 (3) ms			4 (2) ms	0.25 (0) ms		RW	Txt				US
03.088	Encoder Simulation Mode	Hardware (0), Lines Per Rev (1), Ratio (2), SSI (3)			Lines Per Rev (1)	Hardware (0)		RW	Txt				US
03.089	Encoder Simulation Hardware Divider	0 to 7			0			RW	Num				US
03.090	Encoder Simulation Hardware Marker Lock	Off (0) or On (1)			Off (0)			RW	Bit				US
03.091	Encoder Simulation Incremental Mode Select	Off (0) or On (1)			On (1)	Off (0)		RW	Bit				US
03.092	Encoder Simulation Output Lines Per Revolution	1 to 16384			1024	4096		RW	Num				US
03.093	Encoder Simulation Numerator	1 to 65536			65536			RW	Num				US
03.094	Encoder Simulation Denominator	1 to 65536			65536			RW	Num				US

Parameter	Range			Default			Type					
	OL	RFC-A	RFC-S	OL	RFC-A	RFC-S						
03.095	Encoder Simulation Output Roll-over Limit	1 to 65535			65535			RW	Num			US
03.096	Encoder Simulation SSI Turns Bits	0 to 16			16			RW	Num			US
03.097	Encoder Simulation SSI Position Bits	2 to 48			33			RW	Num			US
03.098	Encoder Simulation Output Mode	AB/Gray (0), FD/Binary (1), FR/Binary (2)			AB/Gray (0)			RW	Txt			US
03.100	F1 Freeze Trigger Source	Dig I/O 4 (0), Dig I/O 5 (1), Z1 (2), Z2 (3), Common (4)			Dig I/O 4 (0)			RW	Txt			US
03.101	F1 Freeze Mode	Rising 1st (0), Falling 1st (1), Rising all (2), Falling all (3)			Rising 1st (0)			RW	Txt			US
03.102	F1 Freeze Position Source	P1 (0) or P2 (1)			P1 (0)			RW	Txt			US
03.103	F1 Normalized Freeze Position	-2147483648 to 2147483647						RO	Num	ND	NC	PT
03.104	F1 Freeze Flag	Off (0) or On (1)						RO	Bit	ND	NC	PT
03.105	F2 Freeze Trigger Source	Dig I/O 4 (0), Dig I/O 5 (1), Z1 (2), Z2 (3), Common (4)			Dig I/O 4 (0)			RW	Txt			US
03.106	F2 Freeze Mode	Rising 1st (0), Falling 1st (1), Rising all (2), Falling all (3)			Rising 1st (0)			RW	Txt			US
03.107	F2 Freeze Position Source	P1 (0) or P2 (1)			P1 (0)			RW	Txt			US
03.108	F2 Normalized Freeze Position	-2147483648 to 2147483647						RO	Num	ND	NC	PT
03.109	F2 Freeze Flag	Off (0) or On (1)						RO	Bit	ND	NC	PT
03.110	Common Freeze Source 1	Dig I/O 4 (0), Dig I/O 5 (1), Z1 (2), Z2 (3), Disabled (4)			Dig I/O 4 (0)			RW	Txt			US
03.111	Common Freeze Source 2	Dig I/O 4 (0), Dig I/O 5 (1), Z1 (2), Z2 (3), Disabled (4)			Dig I/O 4 (0)			RW	Txt			US
03.112	Common Freeze Mode	0000 to 1111			0000			RW	Bin			US
03.113	Freeze Input States	00 to 11						RO	Num	ND	NC	PT
03.118	P1 Thermistor Type	DIN44082 (0), KTY84 (1), 0.8mA (2)			DIN44082 (0)			RW	Txt			US
03.119	P1 Thermistor Feedback	0 to 10000 Ω						RO	Num	ND	NC	PT
03.120	P1 Thermistor Trip Threshold	0 to 10000 Ω			3300 Ω			RW	Num			US
03.121	P1 Thermistor Reset Threshold	0 to 10000 Ω			1800 Ω			RW	Num			US
03.122	P1 Thermistor Temperature	-50 to 300 °C						RO	Num	ND	NC	PT
03.123	P1 Thermistor Fault Detection	None (0), Temperature (1), Temp or Short (2)			None (0)			RW	Bit			US
03.127	P2 Speed Feedback	±VM_SPEED						RO	Num	ND	NC	PT
03.128	P2 Revolution/Pole Pitch Counter	0 to 65535						RO	Num	ND	NC	PT
03.129	P2 Position	0 to 65535						RO	Num	ND	NC	PT
03.130	P2 Fine Position	0 to 65535						RO	Num	ND	NC	PT
03.131	P2 Marker Mode	0000 to 1111			0000			RW	Bin			US
03.132	P2 Marker Flag	Off (0) or On (1)			Off (0)			RW	Bit		NC	
03.133	P2 Rotary Turns Bits	0 to 16			16			RW	Num			US
03.134	P2 Rotary Lines Per Revolution	0 to 100000			1024		4096	RW	Num			US
03.135	P2 Comms Bits	0 to 48			0			RW	Num			US
03.137	P2 Comms Baud Rate	100k (0), 200k (1), 300k (2), 400k (3), 500k (4), 1M (5), 1.5M (6), 2M (7), 4M (8) Baud			300K (2) Baud			RW	Txt			US
03.138	P2 Device type	None (0), AB (1), FD (2), FR (3), EnDat (4), SSI (5), BiSS (6)			None (0)			RW	Txt			US
03.140	P2 Error Detection Level	0000 to 1111			0001			RW	Bin			US
03.141	P2 Auto-configuration Select	Disabled (0), Enabled (1)			Enabled (1)			RW	Txt			US
03.142	P2 Feedback Filter	Disabled (0), 1 (1), 2 (2), 4 (3), 8 (4), 16 (5) ms			Disabled (0)			RW	Txt			US
03.143	P2 Maximum Reference	0 to 50,000 rpm			1500 rpm		3000 rpm	RW	Num			US
03.144	P2 Reference Scaling	0.000 to 4.000			1.000			RW	Num			US
03.145	P2 Reference	±100.0 %						RO	Num	ND	NC	PT
03.146	P2 Reference Destination	0.000 to 59.999			0.000			RW	Num	DE		PT
03.147	P2 SSI Incremental Mode	Off (0) or On (1)			Off (0)			RW	Bit			US
03.148	P2 SSI Binary Mode	Off (0) or On (1)			Off (0)			RW	Bit			US
03.149	P2 Additional Power-up Delay	0.0 to 25.0 s			0.0 s			RW	Num			US
03.150	P2 Feedback Lock	Off (0) or On (1)			Off (0)			RW	Bit			US
03.151	P2 Linear Feedback Select	Off (0) or On (1)			Off (0)			RW	Bit			US
03.152	P2 Linear Comms Pitch	0.001 to 100.000			0.001			RW	Num			US
03.153	P2 Linear Line Pitch	0.001 to 100.000			0.001			RW	Txt			US
03.154	P2 Linear Comms And Line Pitch Units	Millimetres (0) or Micrometres (1)			Millimetres (0)			RW	Txt			US
03.155	P2 Pole Pitch	0.01 to 1000.00 mm			10.00 mm			RW	Num			US
03.156	P2 Feedback Reverse	Off (0) or On (1)			Off (0)			RW	Bit			US
03.157	P2 Normalization Turns	0 to 16			16			RO	Num			US
03.158	P2 Normalized Position	-2147483648 to 2147483647						RO	Num	ND	NC	PT
03.159	P2 Normalized Marker Position	-2147483648 to 2147483647						RO	Num	ND	NC	PT

Safety information	Product information	Electrical installation	Getting started	Basic parameters	Running the motor	Optimization	NV Media Card Operation	Onboard PLC	<b>Advanced parameters</b>	Technical data	Diagnostics	UL listing information
--------------------	---------------------	-------------------------	-----------------	------------------	-------------------	--------------	-------------------------	-------------	----------------------------	----------------	-------------	------------------------

Parameter	Range			Default			Type						
	OL	RFC-A	RFC-S	OL	RFC-A	RFC-S	RW	Num	ND	NC	PT	US	
03.160	P2 Calculation Time	0 to 20 $\mu$ s			5 $\mu$ s			RW	Num				US
03.161	P2 Recovery Time	5 to 100 $\mu$ s			30 $\mu$ s			RW	Num				US
03.162	P2 Line Delay Time	0 to 5000 ns						RO	Num	ND	NC	PT	US
03.163	P2 Low Speed Update Rate Active	Off (0) or On (1)						RO	Bit	ND	NC	PT	
03.164	P2 Encoder Protocol Detected	None (0), Hiperface (1), EnDat 2.1 (2), EnDat 2.2 (3), BiSS (4)						RO	Txt	ND	NC	PT	
03.167	P2 User Comms Enable	0 to 1			0			RW	Num				US
03.168	P2 User Comms Transmit Register	0 to 65535			0			RW	Num				
03.169	P2 User Comms Receive Register	0 to 65535			0			RW	Num				
03.171	P2 Error Detected	Off (0) or On (1)						RO	Bit	ND	NC	PT	
03.172	P2 Status	None (0), AB (1), FD (2), FR (3), EnDat (4), SSI (5), BiSS (6), EnDat Alt (7), SSI Alt (8), BiSS Alt (9)						RO	Txt	ND	NC	PT	

RW	Read / Write	RO	Read only	Num	Number parameter	Bit	Bit parameter	Txt	Text string	Bin	Binary parameter	FI	Filtered
ND	No default value	NC	Not copied	PT	Protected parameter	RA	Rating dependent	US	User save	PS	Power-down save	DE	Destination

## 10.4 Menu 4: Torque and current control

Figure 10-10 Menu 4 Open loop logic diagram

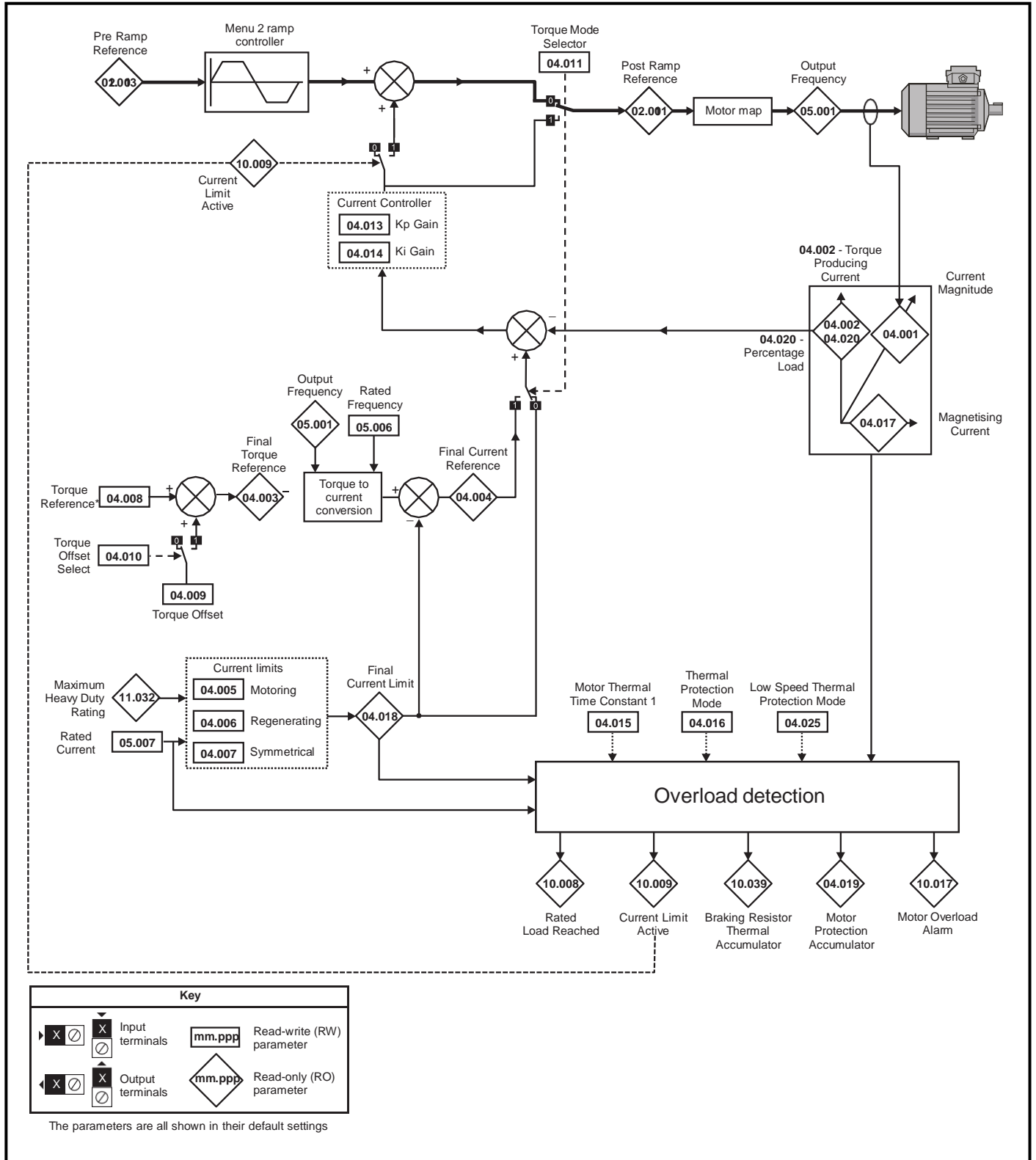

**Figure 10-11 Menu 4 RFC-A logic diagram**

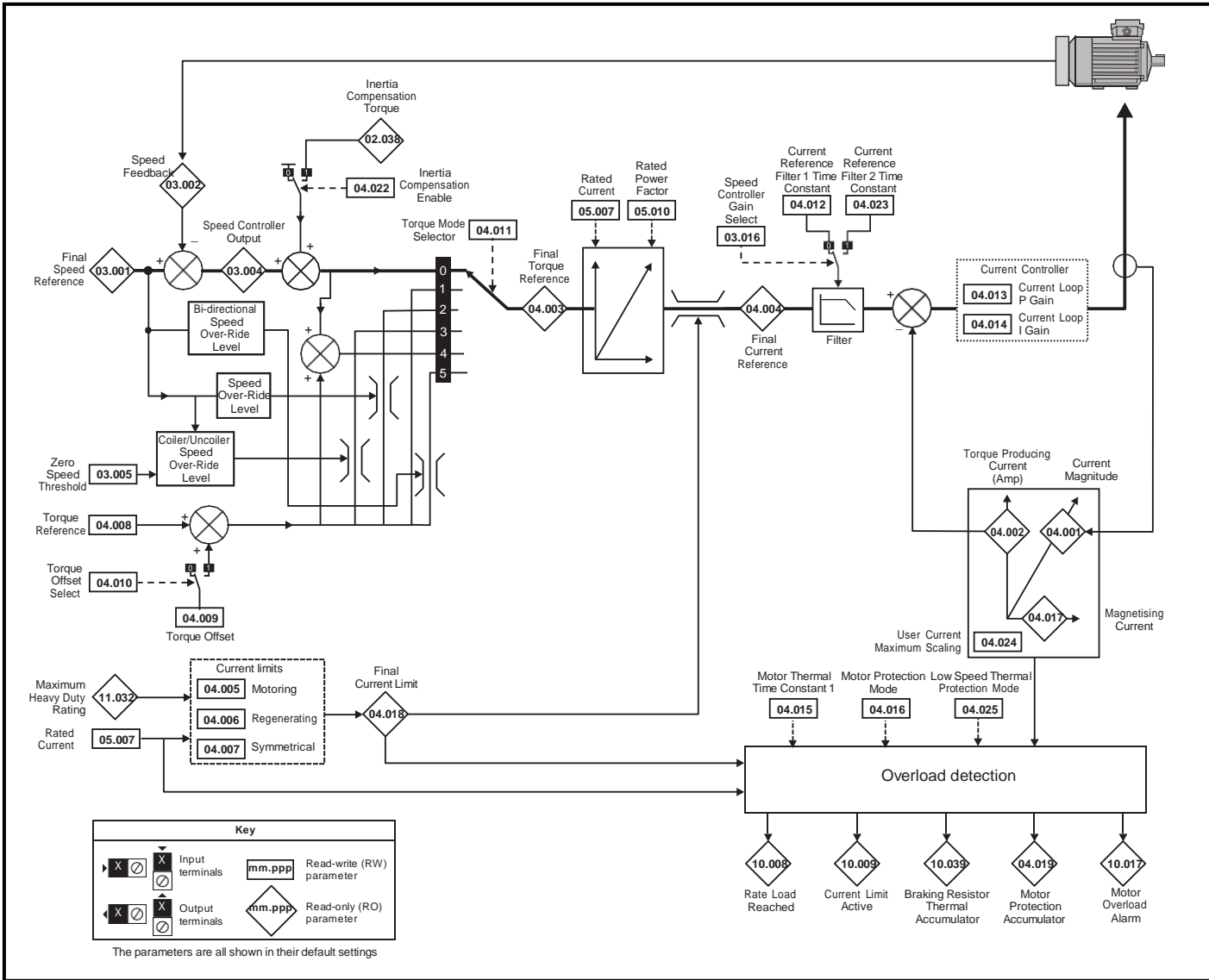
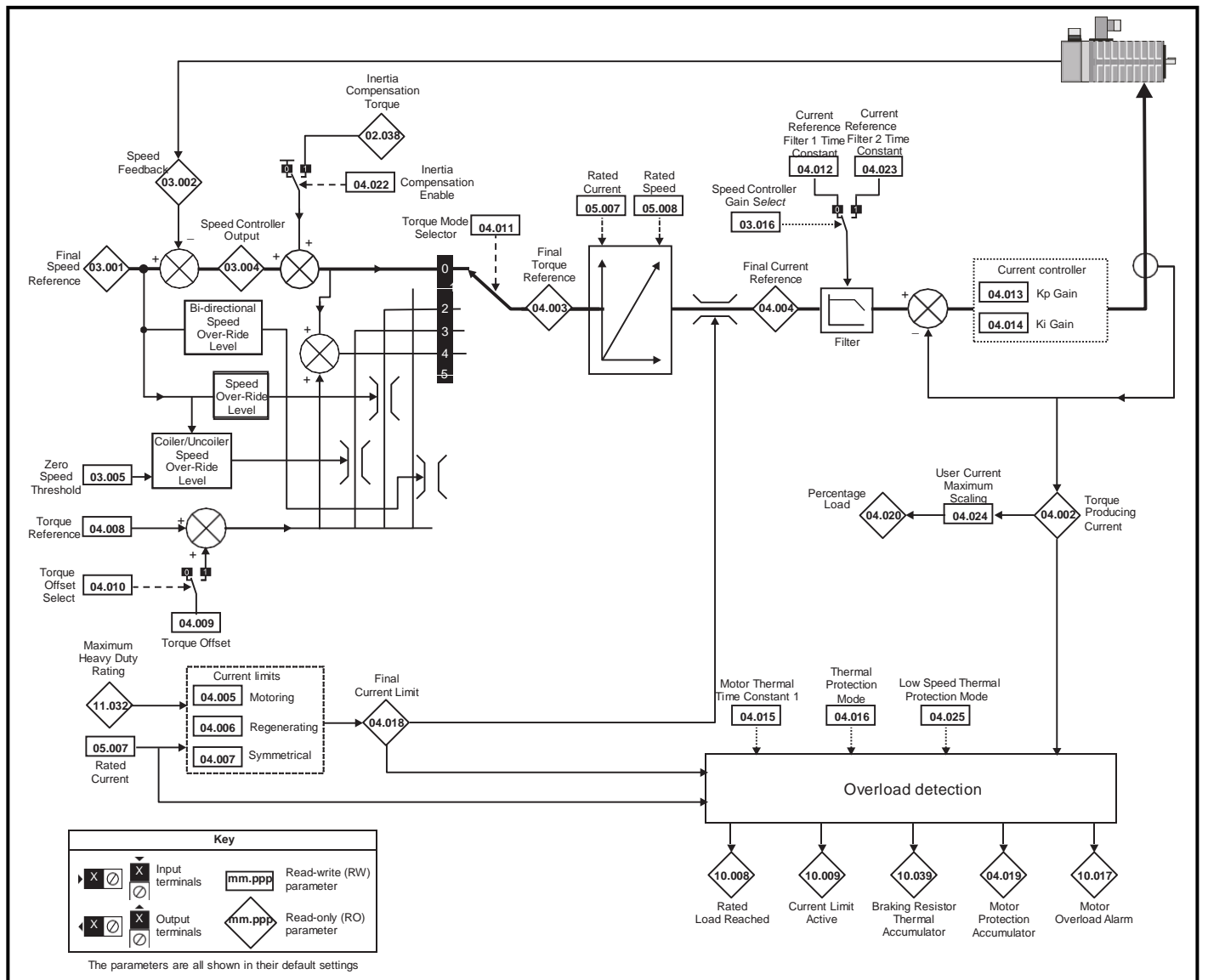

Figure 10-12 Menu 4 RFC-S logic diagram



Parameter	Range(⇅)		Default(→)			Type					
	OL	RFC-A / S	OL	RFC-A	RFC-S	RO	Num	ND	NC	PT	FI
04.001	Current Magnitude	±VM_DRIVE_CURRENT_UNIPOLAR A				RO	Num	ND	NC	PT	FI
04.002	Torque Producing Current	±VM_DRIVE_CURRENT A				RO	Num	ND	NC	PT	FI
04.003	Final Torque Reference	±VM_TORQUE_CURRENT %				RO	Num	ND	NC	PT	FI
04.004	Final Current Reference	±VM_TORQUE_CURRENT %				RO	Num	ND	NC	PT	FI
04.005	Motoring Current Limit	±VM_MOTOR1_CURRENT_LIMIT %		165.0 %	175.0 %	RW	Num		RA		US
04.006	Regenerating Current Limit	±VM_MOTOR1_CURRENT_LIMIT %		165.0 %	175.0 %	RW	Num		RA		US
04.007	Symmetrical Current Limit	±VM_MOTOR1_CURRENT_LIMIT %		165.0 %	175.0 %	RW	Num		RA		US
04.008	Torque Reference	±VM_USER_CURRENT_HIGH_RES %		0.00 %		RW	Num				US
04.009	Torque Offset	±VM_USER_CURRENT %		0.0 %		RW	Num				US
04.010	Torque Offset Select	Off (0) or On (1)		Off (0)		RW	Bit				US
04.011	Torque Mode Selector	0 to 1	0 to 5	0		RW	Num				US
04.012	Current Reference Filter 1 Time Constant		0.0 to 25.0 ms		0.0 ms	RW	Num				US
04.013	Current Controller Kp Gain	0 to 30000		20	150	RW	Num				US
04.014	Current Controller Ki Gain	0 to 30000		40	2000	RW	Num				US
04.015	Motor Thermal Time Constant 1	1.0 to 3000.0 s		89.0 s		RW	Num				US
04.016	Thermal Protection Mode	00 to 11		00		RW	Bin				US
04.017	Magnetising Current	±VM_DRIVE_CURRENT A				RO	Num	ND	NC	PT	FI
04.018	Final Current Limit	±VM_TORQUE_CURRENT %				RO	Num	ND	NC	PT	
04.019	Motor Protection Accumulator	0.0 to 100.0 %				RO	Num	ND	NC	PT	PS
04.020	Percentage Load	±VM_USER_CURRENT %				RO	Num	ND	NC	PT	FI
04.021	Current feedback filter disable	Off (0) or On (1)		Off (0)		RW	Bit				US
04.022	Inertia Compensation Enable		Off (0) or On (1)		Off (0)	RW	Bit				US
04.023	Current Reference Filter 2 Time Constant		0.0 to 25.0 ms		0.0 ms	RW	Num				US
04.024	User Current Maximum Scaling	±VM_TORQUE_CURRENT_UNIPOLAR %		165.0 %	175.0 %	RW	Num		RA		US
04.025	Low Speed Thermal Protection Mode	0 to 1		0		RW	Num				US
04.026	Percentage Torque	±VM_USER_CURRENT %				RO	Num	ND	NC	PT	FI
04.027	Low Load Detection Level	0.0 to 100.0 %		0.0 %		RW	Num				US
04.028	Low Load Detection Speed/Frequency Threshold	±VM_SPEED_FREQ_REF_UNIPOLAR		0.0		RW	Num				US
04.029	Enable Trip On Low Load	Off (0) or On (1)		Off (0)		RW	Bit				US
04.030	Current Controller Mode		Off (0) or On (1)		Off (0)	RW	Bit				US
04.031	Notch Filter Centre Frequency		50 to 1000 Hz		100 Hz	RW	Num				US
04.032	Notch Filter Bandwidth		0 to 500 Hz		0 Hz	RW	Num				US
04.033	Inertia Times 1000		Off (0) or On (1)		Off (0)	RW	Bit				US
04.036	Motor Protection Accumulator Power-up Value	Power down (0), Zero (1), Real time (2)		Power down (0)		RW	Txt				US
04.037	Motor Thermal Time Constant 2	1.0 to 3000.0 s		89.0 s		RW	Num				US
04.038	Motor Thermal Time Constant 2 Scaling	0 to 100 %		0 %		RW	Num				US
04.039	Rated Iron Losses As Percentage Of Losses	0 to 100 %		0 %		RW	Num				US

RW	Read / Write	RO	Read only	Num	Number parameter	Bit	Bit parameter	Txt	Text string	Bin	Binary parameter	FI	Filtered
ND	No default value	NC	Not copied	PT	Protected parameter	RA	Rating dependent	US	User save	PS	Power-down save	DE	Destination

## 10.5 Menu 5: Motor control

Figure 10-13 Menu 5 Open-loop logic diagram

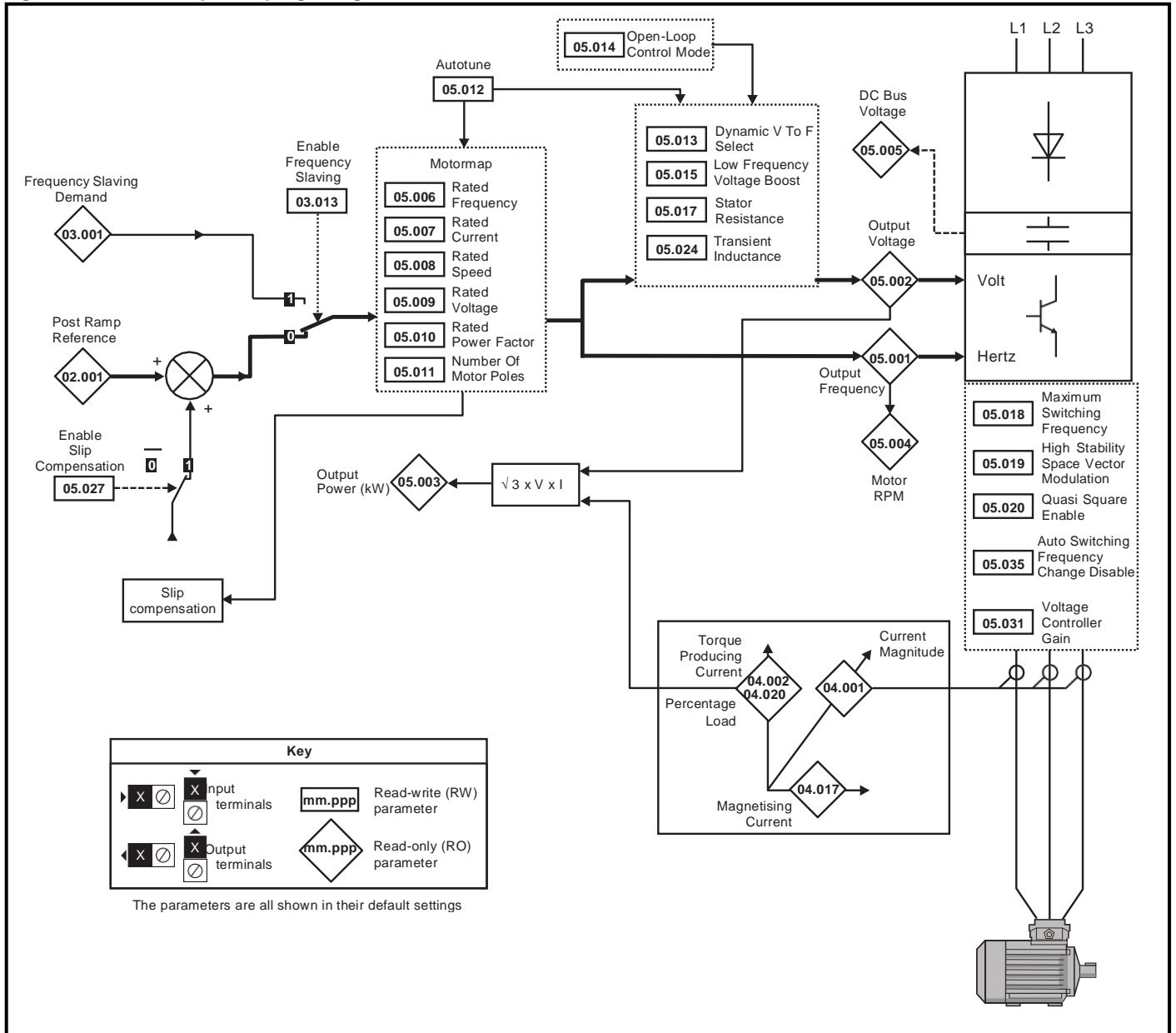
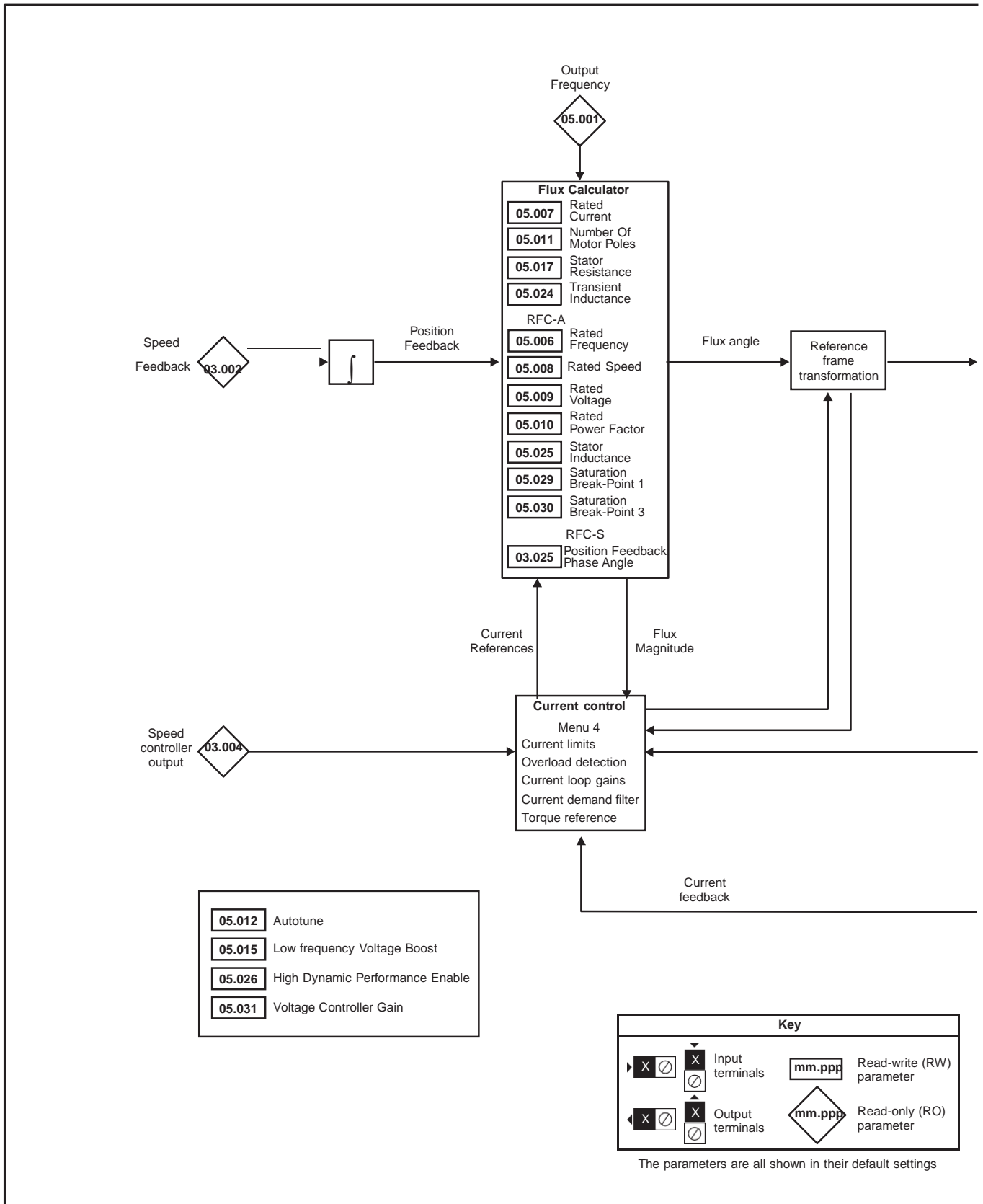
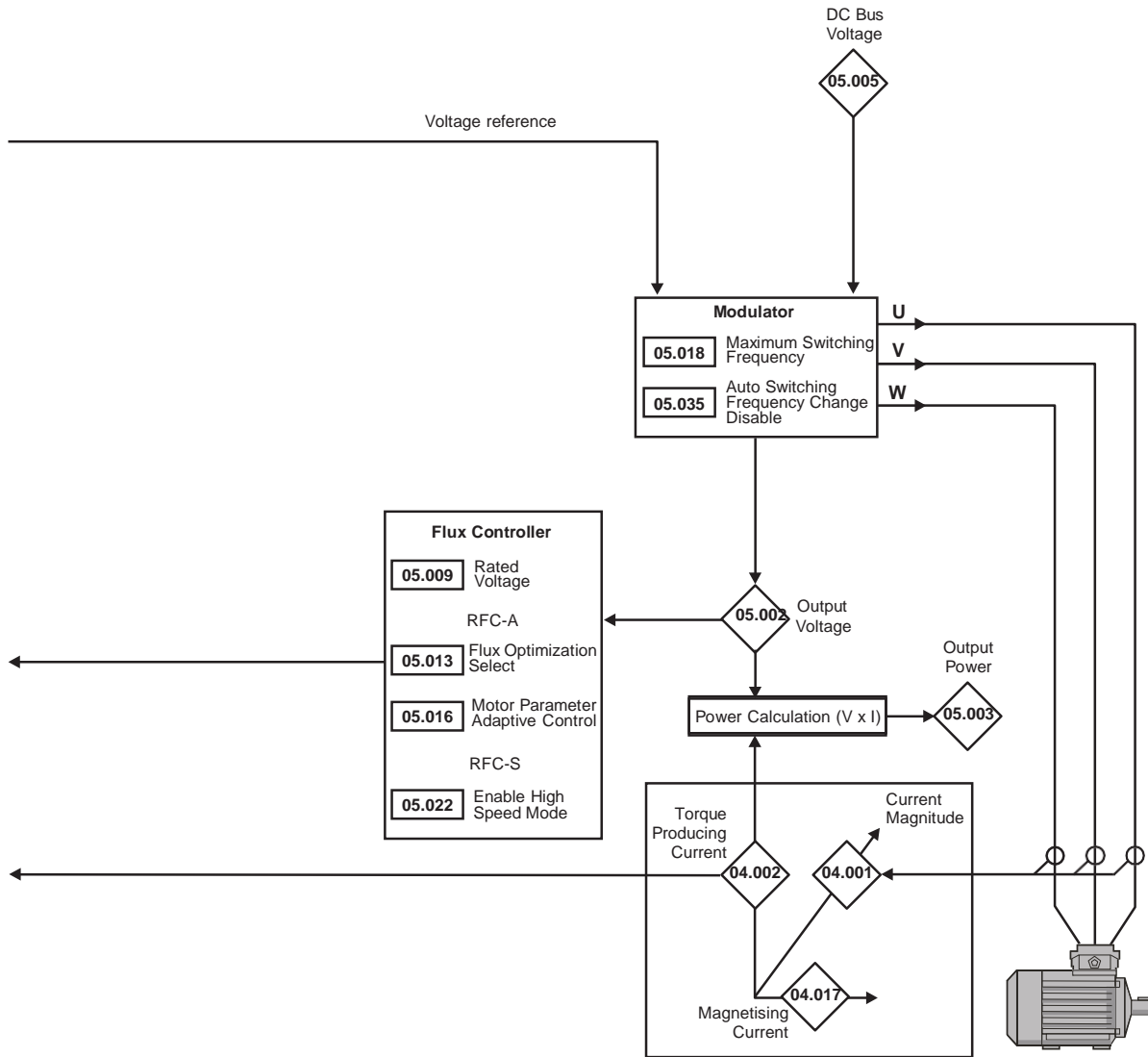



Figure 10-14 Menu 5 RFC-A, RFC-S logic diagram





Parameter	Range(↕)			Default(⇔)			Type						
	OL	RFC-A	RFC-S	OL	RFC-A	RFC-S							
05.001	Output Frequency	±VM_SPEED_FREQ_REF	±2000.0 Hz					RO	Num	ND	NC	PT	FI
05.002	Output Voltage	±VM_AC_VOLTAGE V						RO	Num	ND	NC	PT	FI
05.003	Output Power	±VM_POWER kW						RO	Num	ND	NC	PT	FI
05.004	Motor Rpm	±180000 rpm						RO	Num	ND	NC	PT	FI
05.005	DC Bus Voltage	±VM_DC_VOLTAGE V						RO	Num	ND	NC	PT	FI
05.006	Rated Frequency	0.0 to 3000.0 Hz	0.0 to 1667.0 Hz			50Hz: 50.0 60Hz: 60.0	RW	Num					US
05.007	Rated Current	±VM_RATED_CURRENT A			Maximum Heavy Duty Rating 11.032			RW	Num		RA		US
05.008	Rated Speed	0 to 180000 rpm	0.00 to 50000.00 rpm		50Hz: 1500.0 rpm 60Hz: 1800.0 rpm	50Hz: 1450.00 rpm 60Hz: 1750.00 rpm	3000.00 rpm	RW	Num				US
05.009	Rated Voltage	±VM_AC_VOLTAGE_SET			200V drive: 230 V 50 Hz - 400V drive: 400 V 60 Hz - 400V drive: 460 V 575V drive: 575 V			RW	Num		RA		US
05.010	Rated Power Factor	0.000 to 1.000				0.850	RW	Num		RA			US
05.011	Number Of Motor Poles	Automatic (0) to 480 Poles (240)			Automatic (0) to 6 Poles (3)								
05.012	Autotune	0 to 2	0 to 5	0 to 6	0			RW	Txt				US
05.013	OL: Dynamic V To F Select	Off (0) or On (1)			Off (0)			RW	Bit				US
	RFC-A Flux Optimization Select	Off (0) or On (1)			Off (0)			RW	Bit				US
05.014	OL: Open-loop Control Mode	Ur S (0), Ur I (1), Fixed (2), Ur Auto (3), Ur I (4), Square (5), Current 1P (6)				Ur I (4)	RW	Txt					US
	RFC: Action On Enable			None (0), Phase (1), Phase Init (2)		None (0)							
05.015	Low Frequency Voltage Boost	0.0 to 25.0 %				3.0 %	RW	Num					US
05.016	Motor Parameter Adaptive Control			0 to 2		0	RW	Num					US
05.017	Stator Resistance	0.000000 to 1000.000000 Ω			0.000000 Ω			RW			RA		US
05.018	Maximum Switching Frequency	2 kHz (0), 3 kHz (1), 4 kHz (2), 6 kHz (3), 8 kHz (4), 12 kHz (5), 16 kHz (6)			3 kHz (1)		6 kHz (3)	RW	Txt		RA		US
05.019	High Stability Space Vector Modulation	Off (0) or On (1)			Off (0)			RW	Bit				US
05.020	Quasi-square Enable	Off (0) or On (1)			Off (0)			RW	Bit				US
05.021	Mechanical Load Test Level			0 to 100 %		0 %	RW	Num					US
05.022	Enable High Speed Mode			Off (0) or On (1)		Off (0)	RW	Bit					US
05.023	DC Bus Voltage High Range	±VM_HIGH_DC_VOLTAGE V						RO	Num	ND	NC	PT	
05.024	OL: Transient Inductance	0.000 to 500.000 mH			0.000 mH			RW	Num		RA		US
	RFC-A: Transient Inductance	0.000 to 500.000 mH			0.000 mH			RW	Num		RA		US
	RFC-S: Ld	0.000 to 500.000 mH			0.000 mH			RW	Num		RA		US
05.025	Stator Inductance	0.00 to 5000.00 mH				0.00 mH	RW	Num		RA			US
05.026	High Dynamic Performance Enable				Off (0) or On (1)		Off (0)	RW	Bit				US
05.027	Enable Slip Compensation	Off (0) or On (1)			On (1)			RW	Bit				US
05.028	Flux Control Compensation Disable			Off (0) or On (1)		Off (0)	RW	Bit					US
05.029	Saturation Breakpoint 1			0.0 to 100.0 %		50.0 %	RW	Num					US
05.030	Saturation Breakpoint 3			0.0 to 100.0 %		75.0 %	RW	Num					US
05.031	Voltage Controller Gain	1 to 30			1			RW	Num				US
05.032	RFC-A> Torque Per Amp				0.00 to 500.00 Nm/A			RO	Num	ND	NC	PT	
	RFC-S> Torque Per Amp						1.60 Nm/A	RW	Num				US
05.033	Volts Per 1000 rpm			0 to 10,000 V		98							
05.034	Percentage Flux				0.0 to 150.0 %			RO	Num	ND	NC	PT	
05.035	Auto-switching Frequency Change Disable	Enabled (0), Disabled (1), No Ripple Detect (2)			Enabled (0)			RW	Txt				US
05.036	Auto-switching Frequency Step Size	1 to 2			2			RW	Num				US
05.037	Switching Frequency	2 kHz (0), 3 kHz (1), 4 kHz (2), 6 kHz (3), 8 kHz (4), 12 kHz (5), 16 kHz (6)						RO	Txt	ND	NC	PT	
05.038	Minimum Switching Frequency	2 kHz (0), 3 kHz (1), 4 kHz (2), 6 kHz (3), 8 kHz (4), 12 kHz (5), 16 kHz (6)			2 (0) kHz			RW	Txt				US
05.039	Maximum Inverter Temperature Ripple	0.0 to 10.0			1.0			RW	Num				US
05.040	Spin Start Boost	0.0 to 10.0			1.0			RW	Num				US
05.041	Voltage Headroom			0 to 20 %		0 %	RW	Num					US
05.042	Reverse Output Phase Sequence	Off (0) or On (1)			Off (0)			RW	Bit				US

Parameter		Range(⇅)			Default(⇄)			Type					
		OL	RFC-A	RFC-S	OL	RFC-A	RFC-S						
05.044	Stator Temperature Source	An In 3 (0), User (1), P1 Drive (2), P1 Slot 1 (3), P1 Slot 2 (4), P1 Slot 3 (5), P1 Slot 4 (6)			An In 3 (0)*			RW	Txt				US
05.045	User Stator Temperature	-50 to 300 °C			0 °C			RW	Num				
05.046	Stator Temperature	-50 to 300 °C						RO	Num	ND	NC	PT	
05.047	Stator Temperature Coefficient	0.00000 to 0.10000 °C <sup>-1</sup>			0.00390 °C <sup>-1</sup>			RW	Num				US
05.048	Stator Base Temperature	-50 to 300 °C			0 °C			RW	Num				US
05.049	Enable Stator Compensation	Off (0) or On (1)			Off (0)			RW	Bit				US
05.050	Temperature Compensated Stator Resistance	0.000000 to 1000.000000 $\Lambda$	0.000000 to 1000.000000					RO	Num	ND	NC	PT	
05.051	Rotor Temperature Source	An In 3 (0), User (1), P1 Drive (2), P1 Slot 1 (3), P1 Slot 2 (4), P1 Slot 3 (5), P1 Slot 4 (6)			An In 3 (0)*			RW	Txt				US
05.052	User Rotor Temperature	-50 to 300 °C			0 °C			RW	Num				US
05.053	Rotor Temperature	-50 to 300 °C						RO	Num	ND	NC	PT	
05.054	Rotor Temperature Coefficient	0.00000 to 0.10000 °C <sup>-1</sup>			0.00390 °C <sup>-1</sup>	0.00100 °C <sup>-1</sup>		RW	Num				US
05.055	Rotor Base Temperature	-50 to 300 °C			0 °C			RW	Num				US
05.056	Enable Rotor Compensation	Off (0) or On (1)			Off (0)			RW	Bit				US
05.057	OL: Temperature compensated rated speed	0.00 to 18000.00 rpm						RO	Num	ND	NC	PT	
	RFC-A: Temperature compensated rated speed		0.00 to 50000.00 rpm						RO	Num	ND	NC	PT
	RFC-S: Rotor Temperature Compensation			0.000 to 2.000				RO	Num	ND	NC	PT	
05.059	Maximum Deadtime Compensation	0.000 to 10.000 $\mu$ s			0.000 $\mu$ s			RO	Num		NC	PT	US
05.060	Current At Maximum Deadtime Compensation	0.00 to 100.00 %			0.00 %			RO	Num		NC	PT	US
05.061	Disable Deadtime Compensation	Off (0) or On (1)			Off (0)			RW	Bit				US
05.062	Saturation Breakpoint 2		0.0 to 100.0 %				0.0 %	RW	Num				US
05.063	Saturation Breakpoint 4		0.0 to 100.0 %				0.0 %	RW	Num				US
05.064	RFC Low Speed Mode			Injection (0) or Non-salient (1)			Injection (0)	RW	Txt				US
05.065	Saliency Torque Control			Off (0) or On (1)			Off (0)	RW	Bit				US
05.067	Percentage Over-current Trip Level			10 (0), 20 (1), 30 (2), 40 (3), 50 (4), 60 (5), 70 (6), 80 (7), 90 (8), 100 (9) %			100 (9) %	RW	Txt				US
05.070	Inverted Saturation Characteristic			Off (0) or On (1)			Off (0)	RW	Bit				US
05.071	Low Speed Sensorless Mode Current Limit			0.0 to 1000.0 %			20.0 %	RW	Num		RA		US
05.072	No-load Lq			0.000 to 500.000 mH			0.000 mH	RW	Num		RA		US
05.075	Iq Test Current For Inductance Measurement			0 to 200 %			100 %	RW	Num				US
05.077	Phase Offset At Iq Test Current			$\pm$ 90.0 °			0.0 °	RW	Num		RA		US
05.078	Lq At The Defined Iq Test Current			0.000 to 500.000 mH			0.000 mH	RW	Num		RA		US
05.082	Id Test Current for Inductance Measurement			-100 to 0 %			-50 %	RW	Num				US
05.084	Lq At The Defined Id Test Current			0.000 to 500.000 mH			0.000 mH	RW	Num		RA		US
05.088	Estimated Lq			0.000 to 500.000 mH				RO	Num	ND	NC	PT	FI
05.090	Torque Ripple Compensation	Off (0) or On (1)			Off (0)			RW	Bit				US
05.091	Torque ripple compensation magnitude 1	0.0 to 100 %			0.00 %			RW	Num				US
05.092	Torque ripple compensation phase 1	0.0 to 359 °			0.0 °			RW	Num				US
05.093	Torque ripple compensation magnitude 2	0.0 to 100 %			0.00 %			RW	Num				US
05.094	Torque ripple compensation phase 2	0.0 to 359 °			0.0 °			RW	Num				US
05.095	Torque ripple compensation magnitude 3	0.0 to 100 %			0.00 %			RW	Num				US
05.096	Torque ripple compensation phase 3	0.0 to 359 °			0.0 °			RW	Num				US
05.097	Torque ripple compensation magnitude 4	0.0 to 100 %			0.00 %			RW	Num				US
05.098	Torque ripple compensation phase 4	0.0 to 359 °			0.0 °			RW	Num				US
05.099	Torque ripple compensation magnitude 5	0.0 to 100 %			0.00 %			RW	Num				US
05.100	Torque ripple compensation phase 5	0.0 to 359 °			0.0 °			RW	Num				US
05.101	Torque ripple compensation magnitude 6	0.0 to 100 %			0.00 %			RW	Num				US
05.102	Torque ripple compensation phase 6	0.0 to 359 °			0.0 °			RW	Num				US
05.103	Torque ripple compensation magnitude 7	0.0 to 100 %			0.00 %			RW	Num				US
05.104	Torque ripple compensation phase 7	0.0 to 359 °			0.0 °			RW	Num				US
05.105	Torque ripple compensation magnitude 8	0.0 to 100 %			0.00 %			RW	Num				US

Parameter	Range(↕)			Default(⇔)			Type					
	OL	RFC-A	RFC-S	OL	RFC-A	RFC-S						
05.106	Torque ripple compensation phase 8		0.0 to 359 °		0.0 °		RW	Num				US
05.107	Torque ripple compensation magnitude 9		0.0 to 100 %		0.00 %		RW	Num				US
05.108	Torque ripple compensation phase 9		0.0 to 359 °		0.0 °		RW	Num				US
05.109	Torque ripple compensation magnitude 10		0.0 to 100 %		0.00 %		RW	Num				US
05.110	Torque ripple compensation phase 10		0.0 to 359 °		0.0 °		RW	Num				US

\* P1 Drive (2) on *Unidrive HS72*.

## 10.6 Menu 6: Sequencer and clock

Figure 10-15 Menu 6 logic diagram

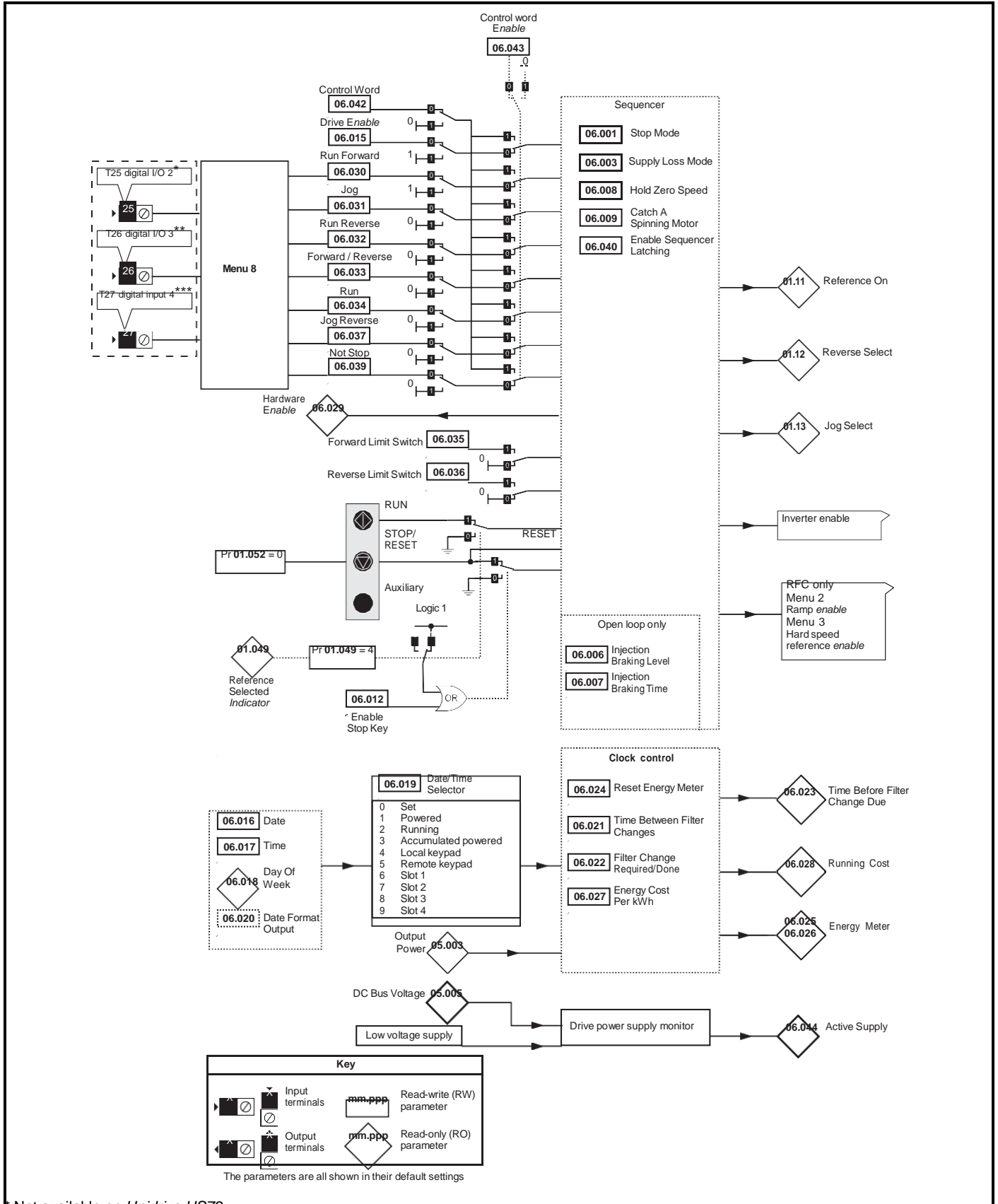

Not available on Unidrive HS72.

\*\* Terminal 7 on Unidrive HS72.

\*\*\* Terminal 8 on Unidrive HS72.

Figure 10-16 Menu 6 Low voltage operation

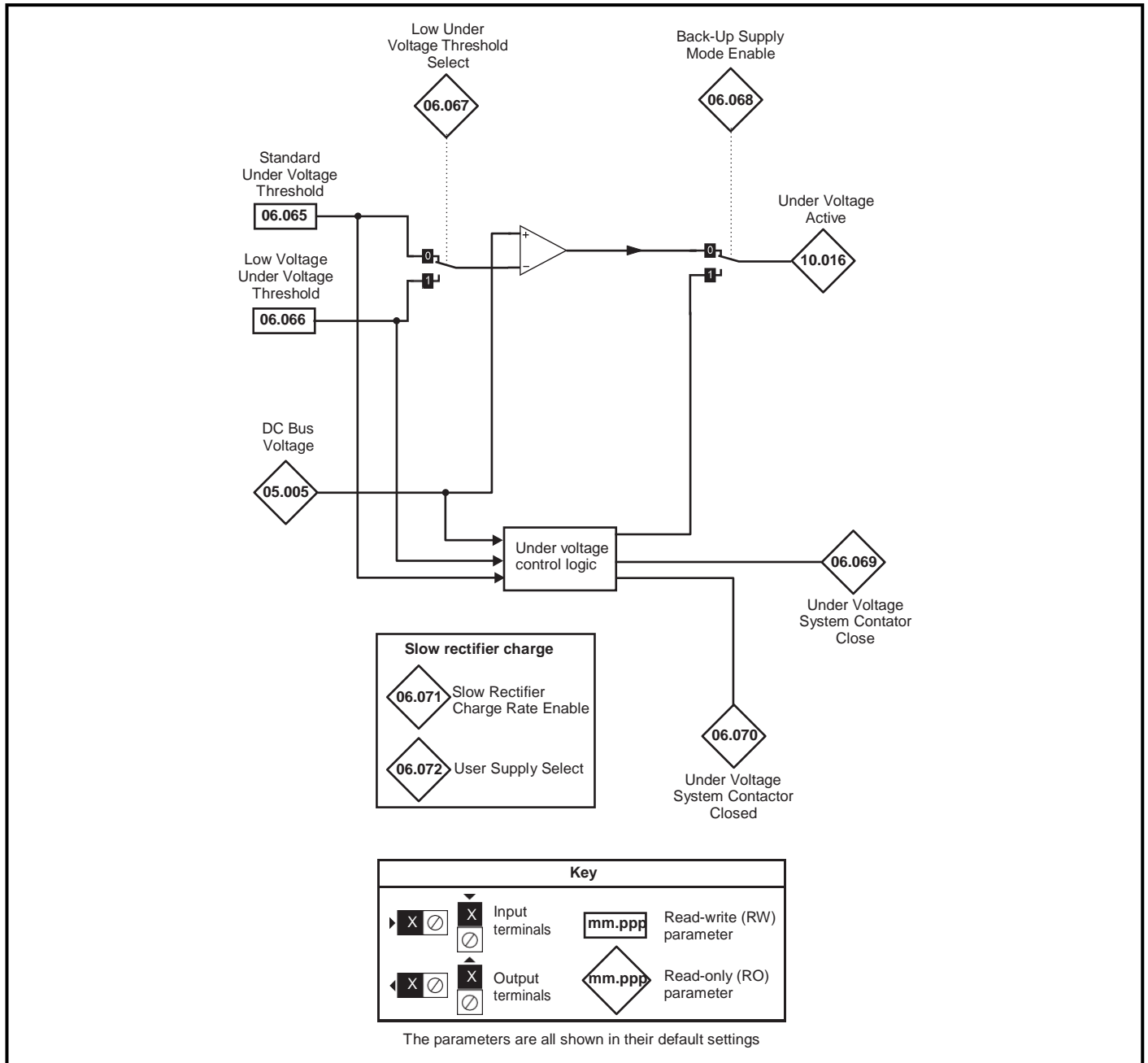

Parameter	Range(↕)		Default(⇔)			Type						
	OL	RFC-A / S	OL	RFC-A	RFC-S	RW	Txt					
06.001	Stop Mode	Coast (0), Ramp (1), Ramp dc I (2), dc I (3), Timed dc I (4), Disable (5)	Coast (0), Ramp (1), No Ramp (2)	Ramp (1)	Ramp (1)	No Ramp (2)	RW	Txt				US
06.002	Limit Switch Stop Mode		Stop (0) or Ramp (1)		Stop (0)		RW	Txt				US
06.003	Supply Loss Mode	Disable (0), Ramp Stop (1), Ride Thru (2)	Disable (0), Ramp Stop (1), Ride Thru (2), Limit Stop (3)	Disable (0)			RW	Txt				US
06.006	Injection Braking Level	0.0 to 150.0 %		100.0 %			RW	Num		RA		US
06.007	Injection Braking Time	0.0 to 25.0 s		1.0 s			RW	Num				US
06.008	Hold Zero Speed	Off (0) or On (1)		Off (0)		On (1)	RW	Bit				US
06.009	Catch A Spinning Motor	Disable (0), Enable (1), Fwd Only (2), Rev Only (3)		Disable (0)	Enable (1)		RW	Txt				US
06.010	Enable Conditions	000000000000 to 111111111111					RO	Bin	ND	NC	PT	
06.011	Sequencer State Machine Inputs	000000 to 111111					RO	Bin	ND	NC	PT	
06.012	Enable Stop Key	Off (0) or On (1)		Off (0)			RW	Bit				US
06.013	Enable Auxiliary Key	Disabled (0), Forward / Reverse (2)		Disabled (0)			RW	Num				US
06.015	Drive Enable	Off (0) or On (1)		On (1)			RW	Bit				US
06.016	Date	00-00-00 to 31-12-99					RW	Date	ND	NC	PT	
06.017	Time	00:00:00 to 23:59:59					RW	Time	ND	NC	PT	
06.018	Day Of Week	Sunday (0), Monday (1), Tuesday (2), Wednesday (3), Thursday (4), Friday (5), Saturday (6)					RO	Txt	ND	NC	PT	
06.019	Date/Time Selector	Set (0), Powered (1), Running (2), Acc Powered (3), Local Keypad (4), Remote Keypad (5), Slot 1 (6), Slot 2 (7), Slot 3 (8), Slot 4 (9)		Powered (1)			RW	Txt				US
06.020	Date Format	Std (0) or US (1)		Std (0)			RW	Txt				US
06.021	Time Between Filter Changes	0 to 30000 Hours		0 Hours			RW	Num				US
06.022	Filter Change Required / Change Done	Off (0) or On (1)					RW	Bit	ND	NC		
06.023	Time Before Filter Change Due	0 to 30000 Hours					RO	Num	ND	NC	PT	PS
06.024	Reset Energy Meter	Off (0) or On (1)		Off (0)			RW	Bit				
06.025	Energy Meter: MWh	-999.9 to 999.0 MWh					RO	Num	ND	NC	PT	PS
06.026	Energy Meter: kWh	±99.99 kWh					RO	Num	ND	NC	PT	PS
06.027	Energy Cost Per kWh	0.0 to 600.0		0.0			RW	Num				US
06.028	Running Cost	±32000					RO	Num	ND	NC	PT	
06.029	Hardware Enable	Off (0) or On (1)					RO	Bit	ND	NC	PT	
06.030	Run Forward	Off (0) or On (1)		Off (0)			RW	Bit		NC		
06.031	Jog	Off (0) or On (1)		Off (0)			RW	Bit		NC		
06.032	Run Reverse	Off (0) or On (1)		Off (0)			RW	Bit		NC		
06.033	Forward/Reverse	Off (0) or On (1)		Off (0)			RW	Bit		NC		
06.034	Run	Off (0) or On (1)		Off (0)			RW	Bit		NC		
06.035	Forward Limit Switch	Off (0) or On (1)		Off (0)			RW	Bit		NC		
06.036	Reverse Limit Switch	Off (0) or On (1)		Off (0)			RW	Bit		NC		
06.037	Jog Reverse	Off (0) or On (1)		Off (0)			RW	Bit		NC		
06.039	Not Stop	Off (0) or On (1)		Off (0)			RW	Bit		NC		
06.040	Enable Sequencer Latching	Off (0) or On (1)		Off (0)			RW	Bit				US
06.041	Drive Event Flags	00 to 11		00			RW	Bin		NC		
06.042	Control Word	00000000000000 to 11111111111111		0000000000000000			RW	Bin		NC		
06.043	Control Word Enable	Off (0) or On (1)		Off (0)			RW	Bit				US
06.044	Active Supply	Off (0) or On (1)					RO	Bit	ND	NC	PT	
06.045	Cooling Fan control	0 to 11		10			RW	Num				US
06.046	Supply Loss Hold Disable	Off (0) or On (1)		Off (0)			RW	Bit				US
06.047	Input Phase Loss Detection Mode	Full (0), Ripple Only (1), Disabled (2)		Full (0)			RW	Txt				US
06.048	Supply Loss Detection Level	±VM_SUPPLY_LOSS_LEVEL V		200 V drive: 205 V 400 V drive: 410 V 575 V drive: 540 V 690 V drive: 540 V			RW	Num		RA		US
06.051	Allow Motoring Load			Off (0) or On (1)			RW	Bit		NC		
06.052	Motor Pre-heat Current Magnitude	0 to 100 %		0 %			RW	Num				US
06.053	Sleep / Wake Threshold	±VM_SPEED_FREQ_REF_UNIPOLAR		0.0			RW	Num				US
06.054	Sleep Time	0.0 to 250.0 s		10.0 s			RW	Num				US
06.055	Wake Time	0.0 to 250.0 s		10.0 s			RW	Num				US
06.056	Sleep Required	Off (0) or On (1)					RO	Bit	ND	NC	PT	
06.057	Sleep Active	Off (0) or On (1)					RO	Bit	ND	NC	PT	

Parameter	Range(⇅)		Default(⇄)			Type					
	OL	RFC-A / S	OL	RFC-A	RFC-S						
06.059	Output Phase Loss Detection Enable	Disable (0) or Enable (1)	Disable (0)			RW	Txt				US
06.060	Standby Mode Enable	Off (0) or On (1)	Off (0)			RW	Bit				US
06.061	Standby Mode Mask	0000000 to 1111111	0000000			RW	Bin				US
06.065	Standard Under Voltage Threshold	±VM_STD_UNDER_VOLTS V	200 V drive: 175 V 400 V drive: 330 V 575 V drive: 435 V 690 V drive: 435 V			RW	Num		RA		US
06.066	Low Voltage Under Voltage Threshold	±VM_LOW_UNDER_VOLTS V	200 V drive: 175 V 400 V drive: 330 V 575 V drive: 435 V 690 V drive: 435 V			RW	Num		RA		US
06.067	Low Under Voltage Threshold Select	Off (0) or On (1)	Off (0)			RW	Bit				US
06.068	Back Up Supply Mode Enable	Off (0) or On (1)	Off (0)			RW	Bit				US
06.069	Under-Voltage System Contactor Close	Off (0) or On (1)				RO	Bit	ND	NC	PT	
06.070	Under-Voltage System Contactor Closed	Off (0) or On (1)	Off (0)			RW	Bit				US
06.071	Slow Rectifier Charge Rate Enable	Off (0) or On (1)	Off (0)			RW	Bit				US
06.072	User Supply Select	Off (0) or On (1)	Off (0)			RW	Bit				US
06.073	Braking IGBT Lower Threshold	±VM_DC_VOLTAGE_SET V	200 V drive: 390 V 400 V drive: 780 V 575 V drive: 930 V 690 V drive: 1120 V			RW	Num				US
06.074	Braking IGBT Upper Threshold	±VM_DC_VOLTAGE_SET V	200 V drive: 390 V 400 V drive: 780 V 575 V drive: 930 V 690 V drive: 1120 V			RW	Num				US
06.075	Low Voltage Braking IGBT Threshold	±VM_DC_VOLTAGE_SET V	0 V			RW	Num				US
06.076	Low Voltage Braking IGBT Threshold Select	Off (0) or On (1)	Off (0)			RW	Bit				

RW	Read / Write	RO	Read only	Num	Number parameter	Bit	Bit parameter	Txt	Text string	Bin	Binary parameter	FI	Filtered
ND	No default value	NC	Not copied	PT	Protected parameter	RA	Rating dependent	US	User save	PS	Power-down save	DE	Destination

## 10.7 Menu 7: Analog I/O / Temperature Monitoring

Figure 10-17 Menu 7 logic diagram (Unidrive HS70 / HS71)

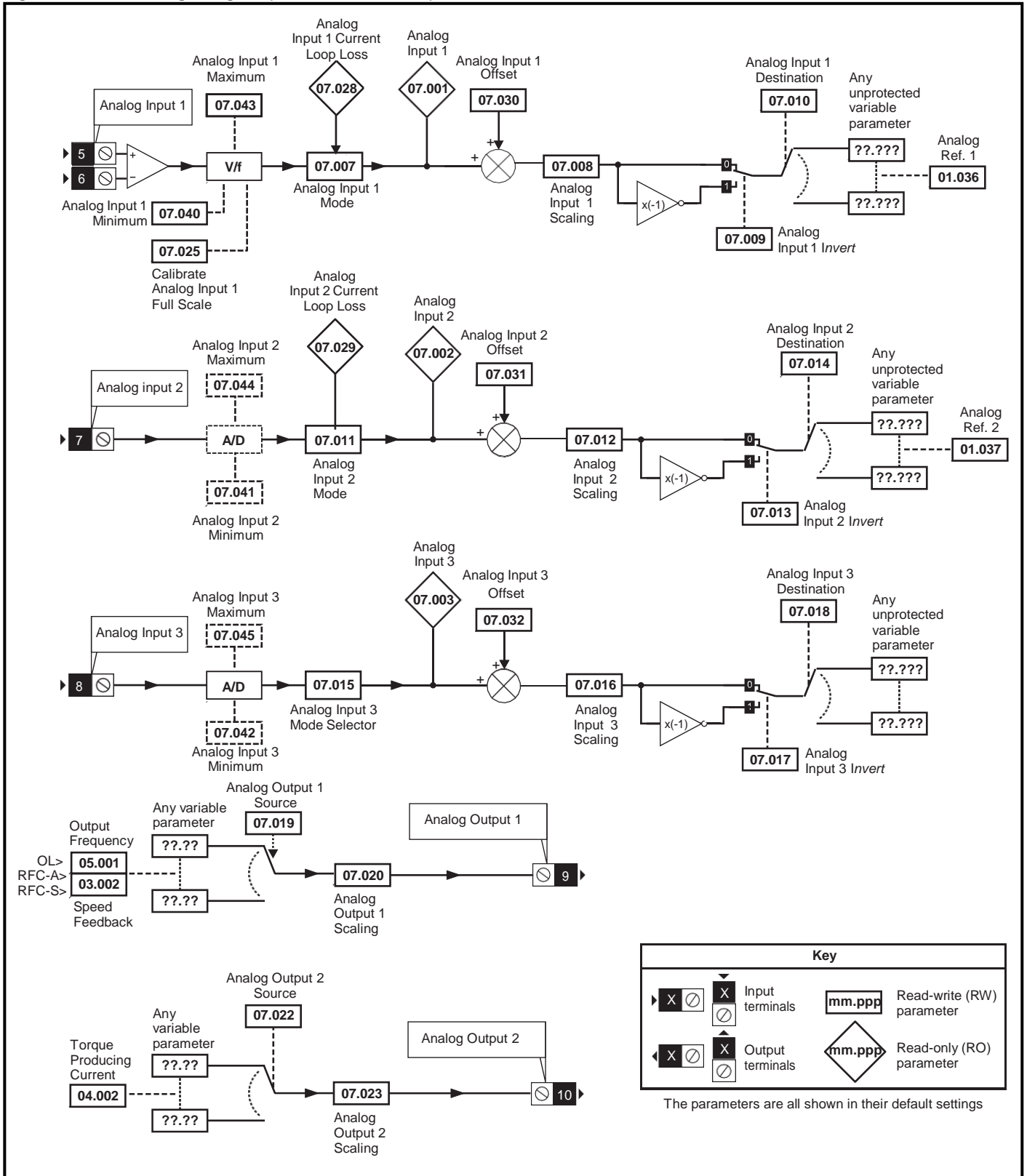

Parameter	Range(⇅)		Default(⇔)			Type					
	OL	RFC-A / S	OL	RFC-A	RFC-S	RO	Num	ND	NC	PT	FI
07.001	Analog Input 1*	±100.00 %				RO	Num	ND	NC	PT	FI
07.002	Analog Input 2*	±100.00 %				RO	Num	ND	NC	PT	FI
07.003	Analog Input 3*	±100.00 %				RO	Num	ND	NC	PT	FI
07.004	Monitored Temperature 1	±250 °C				RO	Num	ND	NC	PT	
07.005	Monitored Temperature 2	±250 °C				RO	Num	ND	NC	PT	
07.006	Monitored Temperature 3	±250 °C				RO	Num	ND	NC	PT	
07.007	Analog Input 1 Mode*	4-20 mA Low (-4), 20-4 mA Low (-3), 4-20 mA Hold (-2), 20-4 mA Hold (-1), 0-20 mA (0), 20-0 mA (1), 4-20 mA Trip (2), 20-4 mA Trip (3), 4-20 mA (4), 20-4 mA (5), Volt (6)		Volt (6)		RW	Txt				US
07.008	Analog Input 1 Scaling*	0.000 to 10.000		1.000		RW	Num				US
07.009	Analog Input 1 Invert*	Off (0) or On (1)		Off (0)		RW	Bit				US
07.010	Analog Input 1 Destination*	0.000 to 59.999		1.036		RW	Num	DE		PT	US
07.011	Analog Input 2 Mode*	4-20 mA Low (-4), 20-4 mA Low (-3), 4-20 mA Hold (-2), 20-4 mA Hold (-1), 0-20 mA (0), 20-0 mA (1), 4-20 mA Trip (2), 20-4 mA Trip (3), 4-20 mA (4), 20-4 mA (5), Volt (6)		Volt (6)		RW	Txt				US
07.012	Analog Input 2 Scaling*	0.000 to 10.000		1.000		RW	Num				US
07.013	Analog Input 2 Invert*	Off (0) or On (1)		Off (0)		RW	Bit				US
07.014	Analog Input 2 Destination*	0.000 to 59.999		1.037		RW	Num	DE		PT	US
07.015	Analog Input 3 Mode*	Volt (6), Therm Short Cct (7), Thermistor (8), Therm No Trip (9)		Volt (6)		RW	Txt				US
07.016	Analog Input 3 Scaling*	0.000 to 10.000		1.000		RW	Num				US
07.017	Analog Input 3 Invert*	Off (0) or On (1)		Off (0)		RW	Bit				US
07.018	Analog Input 3 Destination*	0.000 to 59.999		0.000		RW	Num	DE		PT	US
07.019	Analog Output 1 Source*	0.000 to 59.999		5.001	3.002	RW	Num			PT	US
07.020	Analog Output 1 Scaling*	0.000 to 10.000		1.000		RW	Num				US
07.022	Analog Output 2 Source*	0.000 to 59.999		4.002		RW	Num				US
07.023	Analog Output 2 Scaling*	0.000 to 10.000		1.000		RW	Num				US
07.025	Calibrate Analog Input 1 Full Scale*	Off (0) or On (1)		Off (0)		RW	Bit		NC		
07.026	Analog Input 1 Fast Update Active*	Off (0) or On (1)				RO	Bit	ND	NC	PT	
07.027	Analog Input 2 Fast Update Active*	Off (0) or On (1)				RO	Bit	ND	NC	PT	
07.028	Analog Input 1 Current Loop Loss*	Off (0) or On (1)				RO	Bit	ND	NC	PT	
07.029	Analog Input 2 Current Loop Loss*	Off (0) or On (1)				RO	Bit	ND	NC	PT	
07.030	Analog Input 1 Offset*	±100.00 %		0.00 %		RW	Num				US
07.031	Analog Input 2 Offset*	±100.00 %		0.00 %		RW	Num				US
07.032	Analog Input 3 Offset*	±100.00 %		0.00 %		RW	Num				US
07.033	Power Output	±100.0 %				RO	Num	ND	NC	PT	
07.034	Inverter Temperature	±250 °C				RO	Num	ND	NC	PT	
07.035	Percentage Of d.c. Bus Thermal Trip Level	0 to 100 %				RO	Num	ND	NC	PT	
07.036	Percentage Of Drive Thermal Trip Level	0 to 100 %				RO	Num	ND	NC	PT	
07.037	Temperature Nearest To Trip Level	0 to 29999				RO	Num	ND	NC	PT	
07.038	Temperature Monitor Select 1	0 to 29999		1001		RW	Num				US
07.039	Temperature Monitor Select 2	0 to 29999		1002		RW	Num				US
07.040	Analog Input 1 Minimum*	±100.00 %		-100.00 %		RW	Num				US
07.041	Analog Input 2 Minimum*	±100.00 %		-100.00 %		RW	Num				US
07.042	Analog Input 3 Minimum*	±100.00 %		-100.00 %		RW	Num				US
07.043	Analog Input 1 Maximum*	±100.00 %		100.00 %		RW	Num				US
07.044	Analog Input 2 Maximum*	±100.00 %		100.00 %		RW	Num				US
07.045	Analog Input 3 Maximum*	±100.00 %		100.00 %		RW	Num				US
07.046	Analog Input 3 Thermistor Type*	DIN44082 (0), KTY84 (1), PT100 (4W) (2), PT1000 (4W) (3), PT2000 (4W) (4), 2.0 mA (4W) (5), PT100 (2W) (6), PT1000 (2W) (7), PT2000 (2W) (8), 2.0 mA (2W) (9)		DIN44082 (0)		RW	Txt				US
07.047	Analog Input 3 Thermistor Feedback*	0 to 1000 Ω				RO	Num	ND	NC	PT	
07.048	Analog Input 3 Thermistor Trip Threshold*	0 to 10000 Ω		3300 Ω		RW	Num				US
07.049	Analog Input 3 Thermistor Reset Threshold*	0 to 10000 Ω		1800 Ω		RW	Num				US
07.050	Analog Input 3 Thermistor Temperature*	-50 to 300 °C				RO	Num	ND	NC	PT	
07.051	Analog Input 1 Full Scale*	0 to 65535				RO	Num	ND	NC	PT	PS
07.052	Temperature Monitor Select 3	0 to 29999		1		RW	Num				US

\* Not available on Unidrive HS72.

RW	Read / Write	RO	Read only	Num	Number parameter	Bit	Bit parameter	Txt	Text string	Bin	Binary parameter	FI	Filtered
ND	No default value	NC	Not copied	PT	Protected parameter	RA	Rating dependent	US	User save	PS	Power-down save	DE	Destination



## 10.8 Menu 8: Digital I/O

Figure 10-18 Menu 8 Digital input and outputs logic diagram (Unidrive HS70 / HS71)

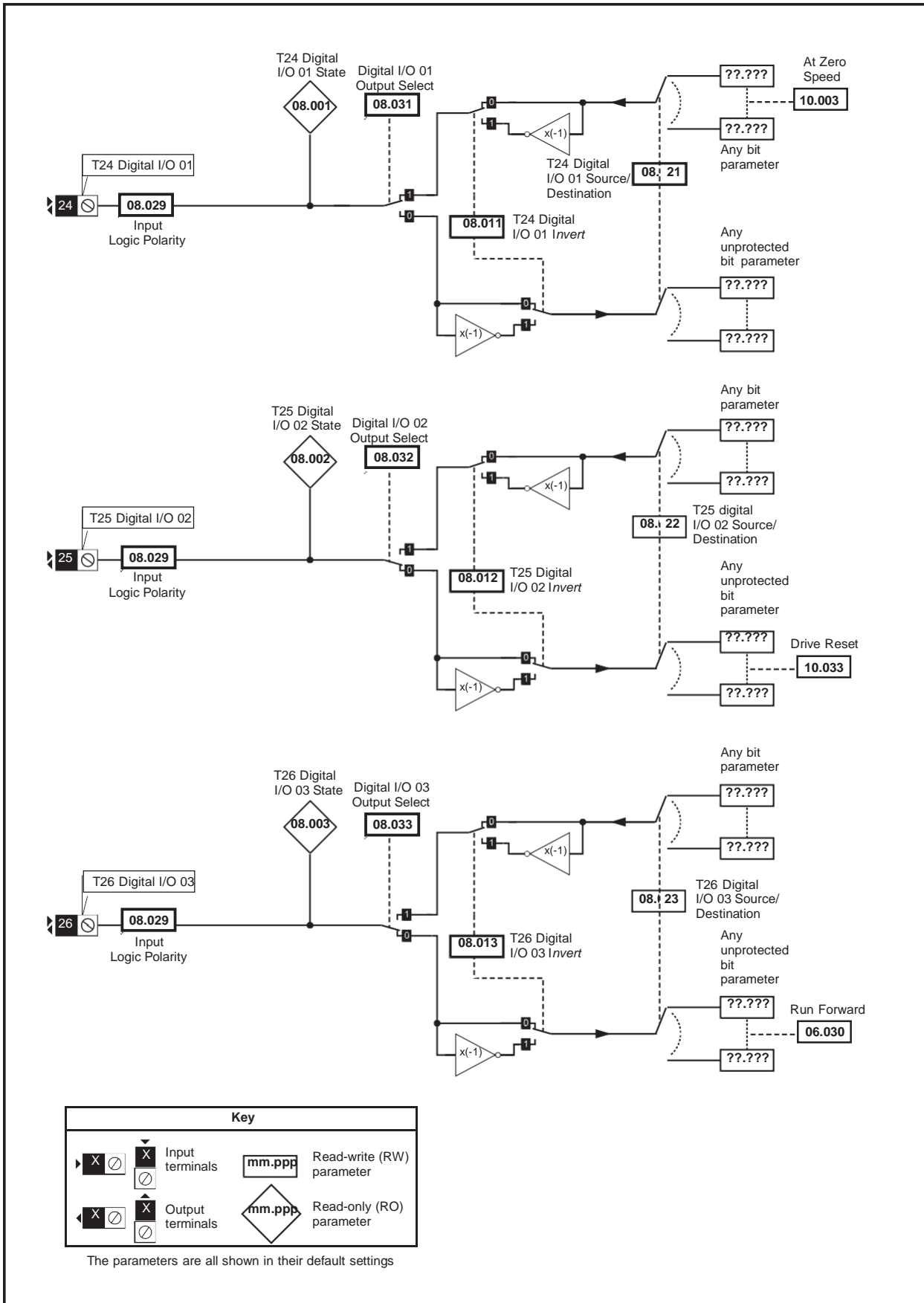

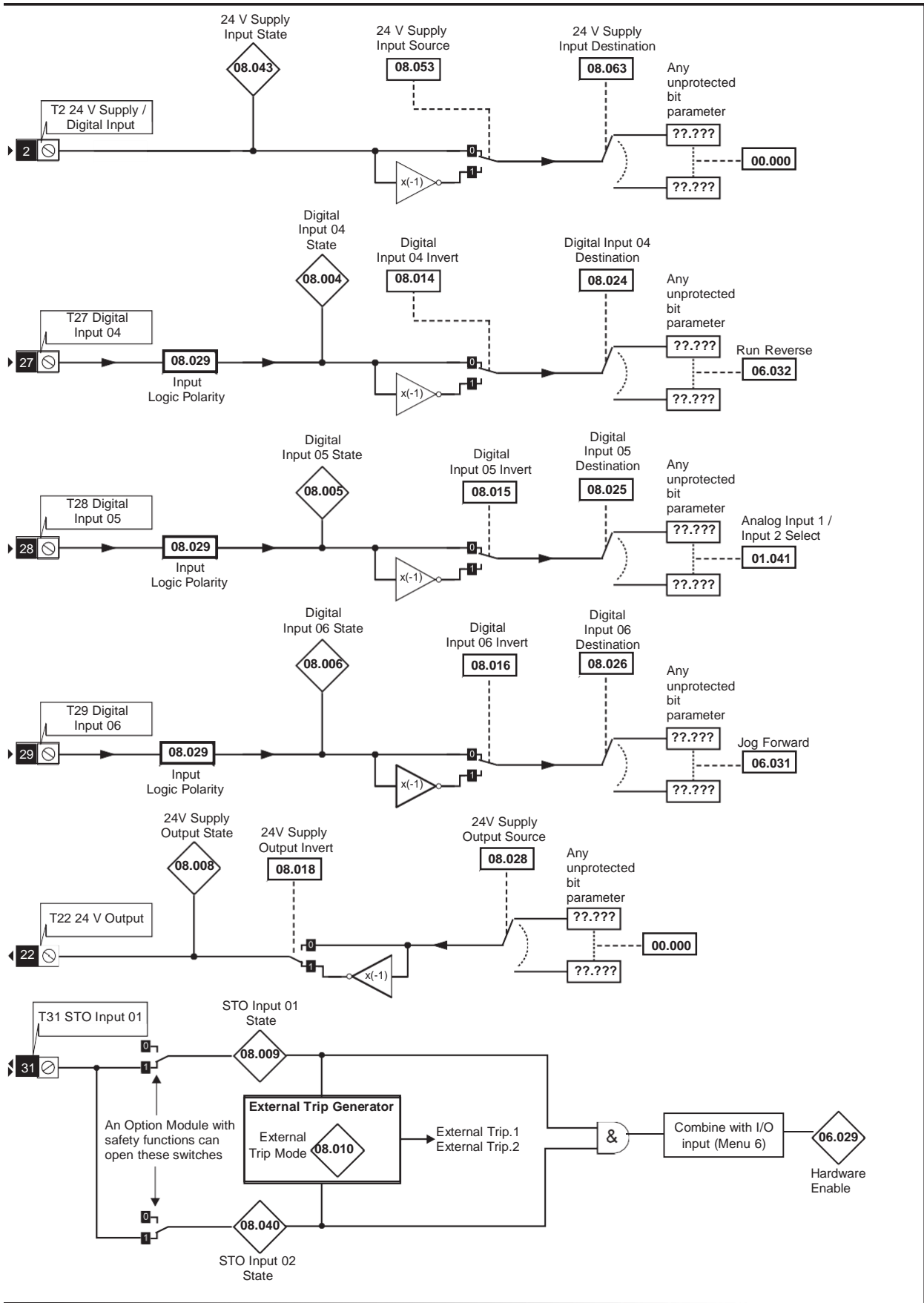
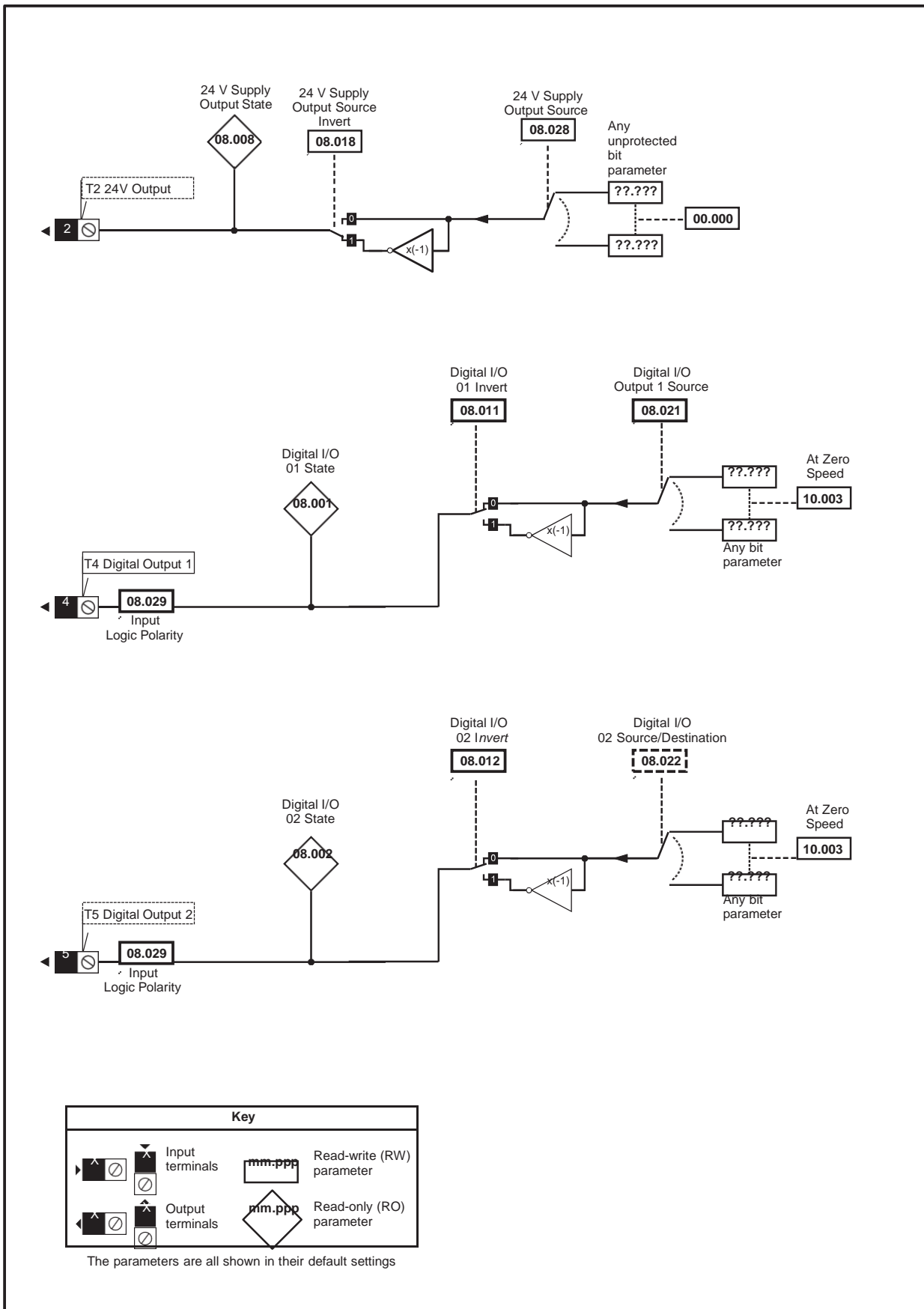

Figure 10-19 Menu 8 Digital input and outputs logic diagram (Unidrive HS72)



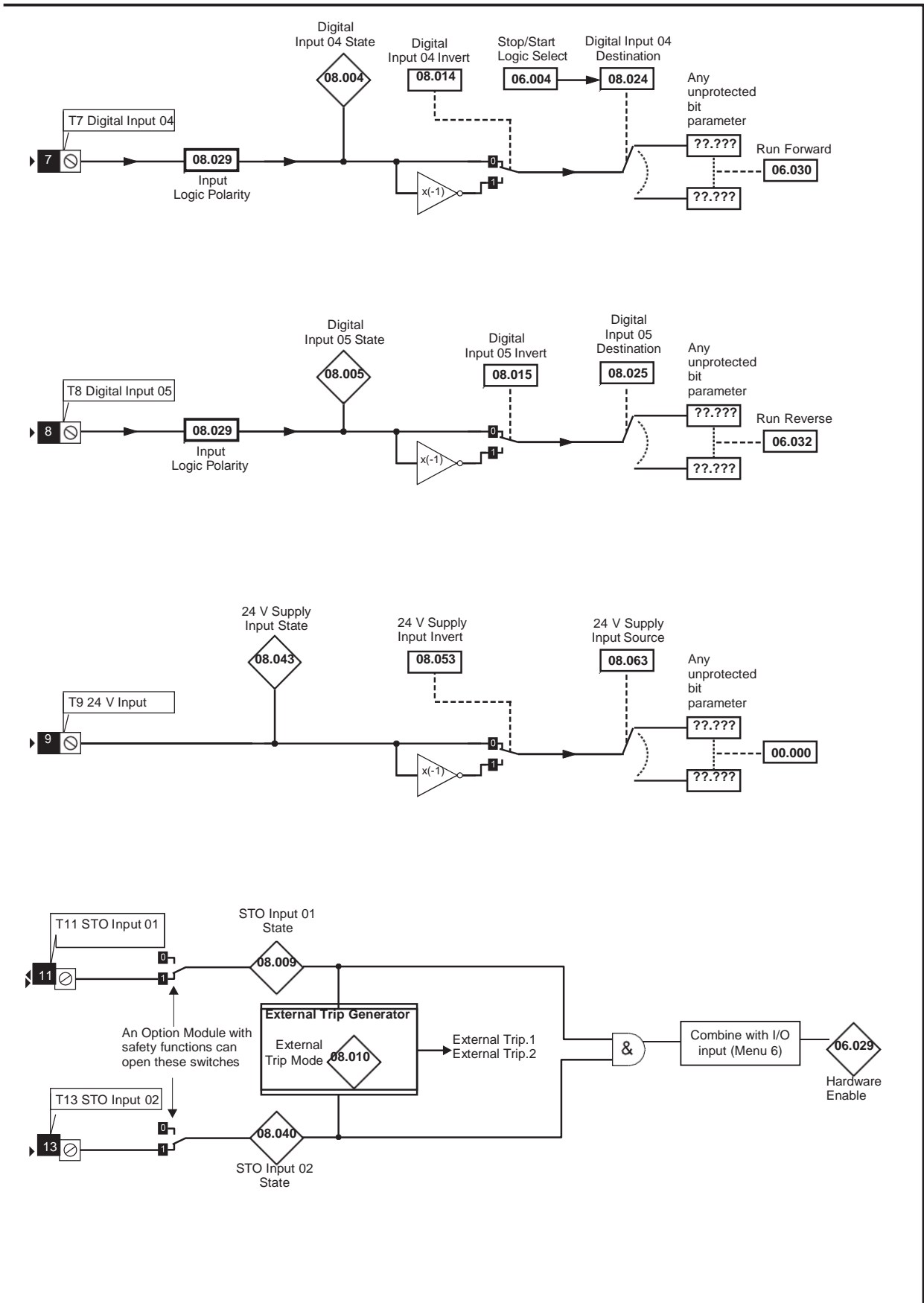

Figure 10-20 Menu 8 Relay output logic diagram

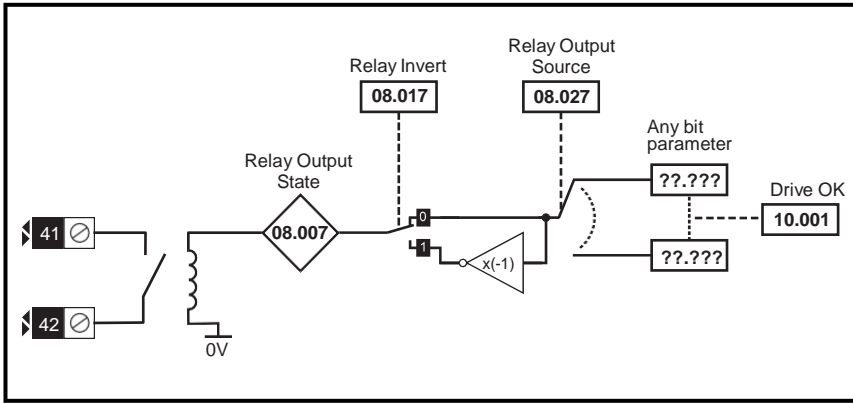
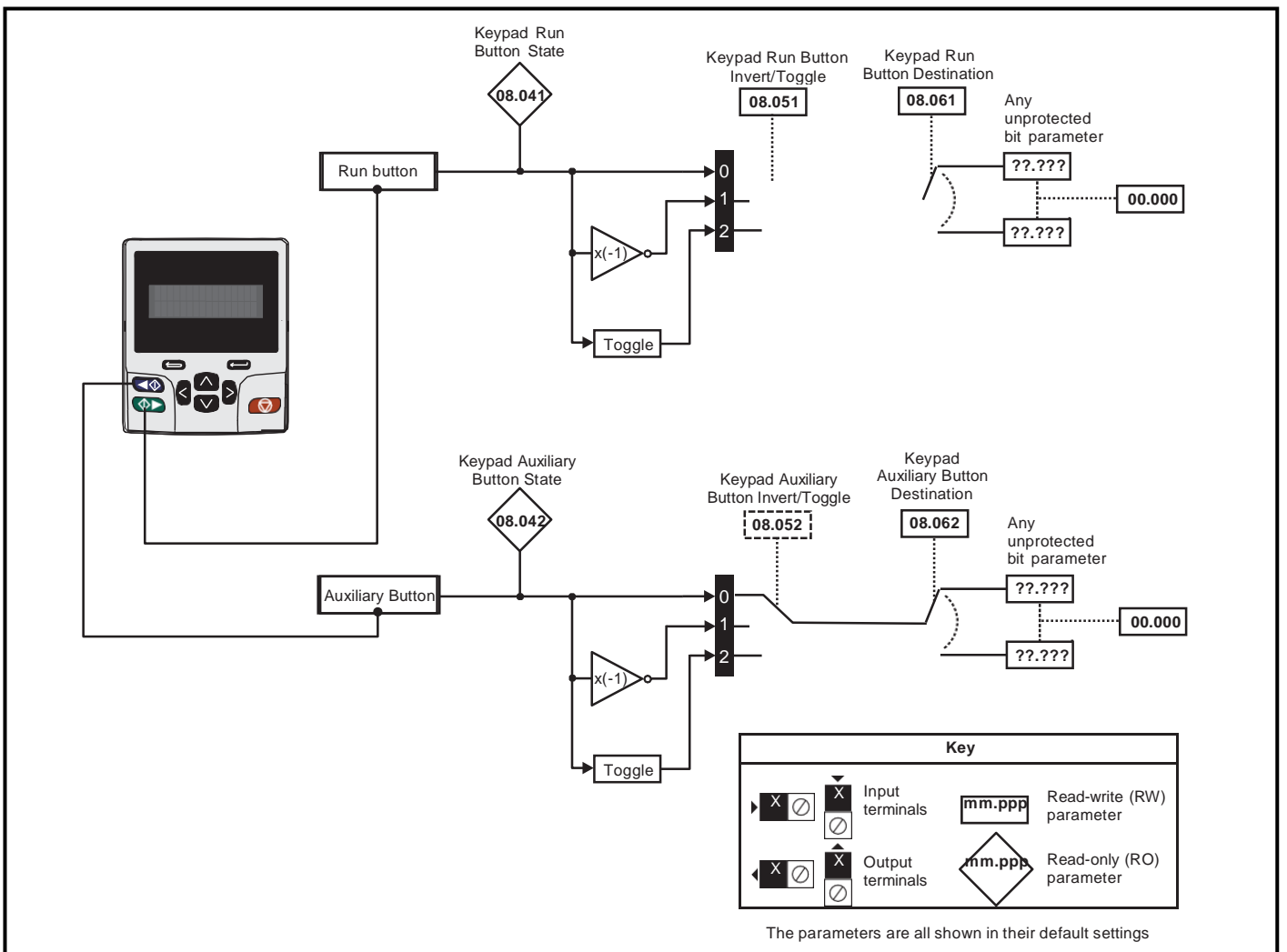

Figure 10-21 Menu 8 Keypad buttons logic diagram



Parameter		Range(⇅)		Default(⇄)			Type					
		OL	RFC-A / S	OL	RFC-A	RFC-S						
08.001	Digital I/O 01 State	Off (0) or On (1)					RO	Bit	ND	NC	PT	
08.002	Digital I/O 02 State	Off (0) or On (1)					RO	Bit	ND	NC	PT	
08.003	Digital I/O 03 State*	Off (0) or On (1)					RO	Bit	ND	NC	PT	
08.004	Digital Input 04 State	Off (0) or On (1)					RO	Bit	ND	NC	PT	
08.005	Digital Input 05 State	Off (0) or On (1)					RO	Bit	ND	NC	PT	
08.006	Digital Input 06 State*	Off (0) or On (1)					RO	Bit	ND	NC	PT	
08.007	Relay Output State	Off (0) or On (1)					RO	Bit	ND	NC	PT	
08.008	24V Supply Output State	Off (0) or On (1)					RO	Bit	ND	NC	PT	
08.009	STO Input 01 State	Off (0) or On (1)					RO	Bit	ND	NC	PT	
08.010	External Trip Mode	Disable (0), STO 1 (1), STO 2 (2), STO 1 OR STO 2 (3)				Disable (0)	RW	Txt				US
08.011	Digital I/O 01 Invert	Not Invert (0) or Invert (1)				Not Invert (0)	RW	Txt				US
08.012	Digital I/O 02 Invert	Not Invert (0) or Invert (1)				Not Invert (0)	RW	Txt				US
08.013	Digital I/O 03 Invert*	Not Invert (0) or Invert (1)				Not Invert (0)	RW	Txt				US
08.014	Digital Input 04 Invert	Not Invert (0) or Invert (1)				Not Invert (0)	RW	Txt				US
08.015	Digital Input 05 Invert	Not Invert (0) or Invert (1)				Not Invert (0)	RW	Txt				US
08.016	Digital Input 06 Invert*	Not Invert (0) or Invert (1)				Not Invert (0)	RW	Txt				US
08.017	Relay Invert	Not Invert (0) or Invert (1)				Not Invert (0)	RW	Txt				US
08.018	24V Supply Output Invert	Not Invert (0) or Invert (1)				Invert (1)	RW	Txt				US
08.020	Digital I/O Read Word	0 to 511					RO	Num	ND	NC	PT	
08.021	Digital I/O 01 Source/Destination	0.000 to 59.999				10.003	RW	Num	DE		PT	US
08.022	Digital I/O 02 Source/Destination	0.000 to 59.999				10.033	RW	Num	DE		PT	US
08.023	Digital I/O 03 Source/Destination*	0.000 to 59.999				6.030	RW	Num	DE		PT	US
08.024	Digital Input 04 Destination	0.000 to 59.999				6.032	RW	Num	DE		PT	US
08.025	Digital Input 05 Destination	0.000 to 59.999				1.041	RW	Num	DE		PT	US
08.026	Digital Input 06 Destination*	0.000 to 59.999				6.031	RW	Num	DE		PT	US
08.027	Relay Output Source	0.000 to 59.999				10.001	RW	Num			PT	US
08.028	24V Supply Output Source	0.000 to 59.999				0.000	RW	Num			PT	US
08.029	Input Logic Polarity	Negative Logic (0) or Positive Logic (1)				Positive Logic (1)	RW	Txt				US
08.031	Digital I/O 01 Output Select*	Off (0) or On (1)				On (1)	RW	Bit				US
08.032	Digital I/O 02 Output Select*	Off (0) or On (1)				Off (0)	RW	Bit				US
08.033	Digital I/O 03 Output Select*	Off (0) or On (1)				Off (0)	RW	Bit				US
08.040	STO Input 02 State	Off (0) or On (1)					RO	Bit	ND	NC	PT	
08.041	Keypad Run Button State	Off (0) or On (1)					RO	Bit	ND	NC	PT	
08.042	Keypad Auxiliary Button State	Off (0) or On (1)					RO	Bit	ND	NC	PT	
08.043	24V Supply Input State	Off (0) or On (1)					RO	Bit	ND	NC	PT	
08.044	Keypad Stop Button State	Off (0) or On (1)					RO	Bit	ND	NC	PT	
08.051	Keypad Run Button Invert/Toggle	Not Invert (0), Invert (1) or Toggle (2)				Not Invert (0)	RW	Txt				US
08.052	Keypad Auxiliary Button Invert/Toggle	Not Invert (0), Invert (1) or Toggle (2)				Not Invert (0)	RW	Txt				US
08.053	24V Supply Input Invert	Not Invert (0) or Invert (1)				Not Invert (0)	RW	Txt				US
08.061	Keypad Run Button Destination	0.000 to 59.999				0.000	RW	Num	DE		PT	US
08.062	Keypad Auxiliary Button Destination	0.000 to 59.999				0.000	RW	Num	DE		PT	US
08.063	24V Supply Input Source	0.000 to 59.999				0.000	RW	Num			PT	US
08.071	DI/O Output Enable Register 1	0000000000000000 to 1111111111111111				0000000000000000	RW	Bin			PT	US
08.072	DI/O Input Register 1	0000000000000000 to 1111111111111111				0000000000000000	RO	Bin			PT	
08.073	DI/O Output Register 1	0000000000000000 to 1111111111111111				0000000000000000	RW	Bin			PT	

\* Not available on *Unidrive HS72*.

RW	Read / Write	RO	Read only	Num	Number parameter	Bit	Bit parameter	Txt	Text string	Bin	Binary parameter	FI	Filtered
ND	No default value	NC	Not copied	PT	Protected parameter	RA	Rating dependent	US	User save	PS	Power-down save	DE	Destination

## 10.9 Menu 9: Programmable logic, motorized pot, binary sum and timers

Figure 10-22 Menu 9 logic diagram: Programmable logic

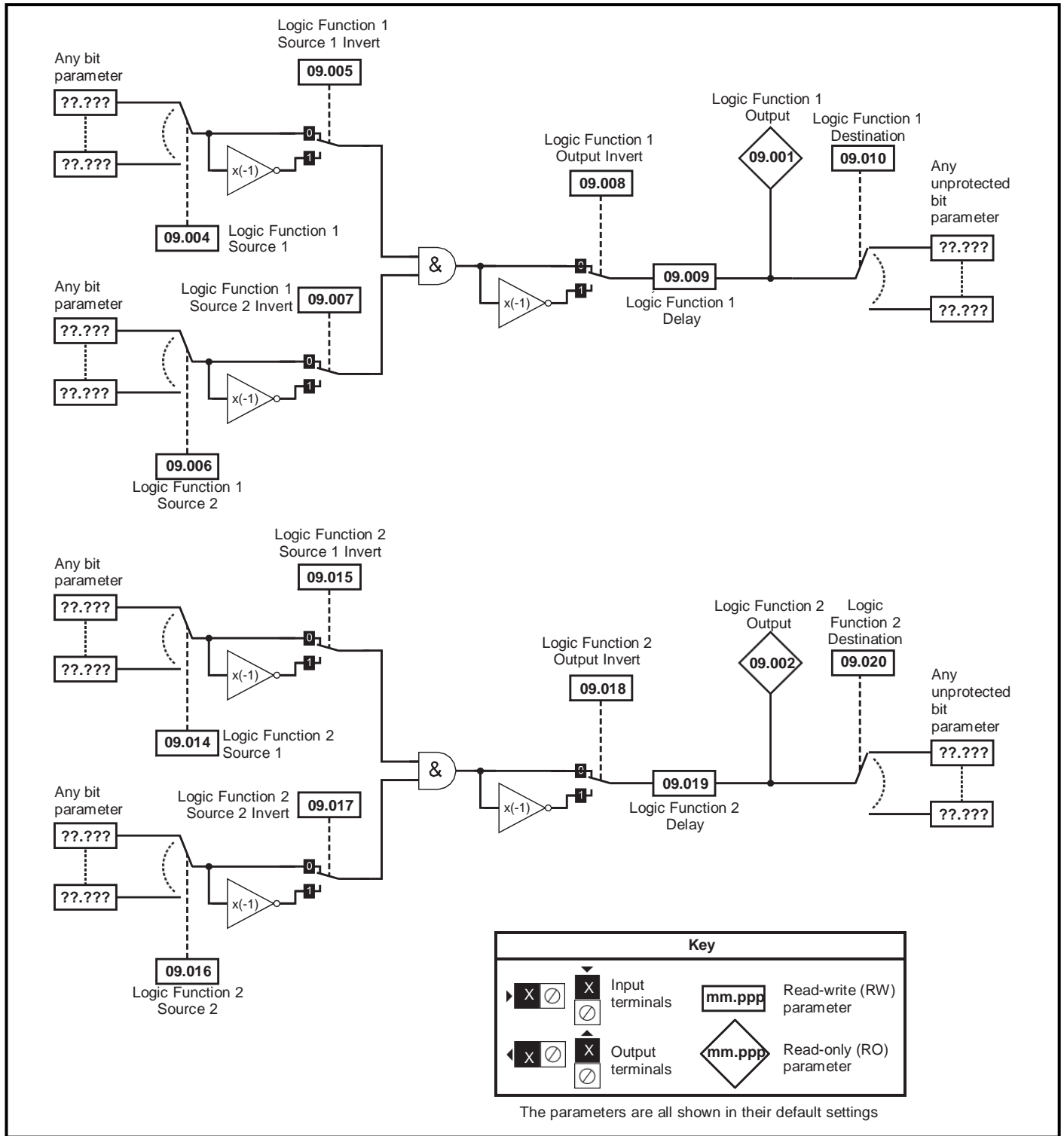

**Figure 10-23 Menu 9 logic diagram: Motorized pot and binary sum**

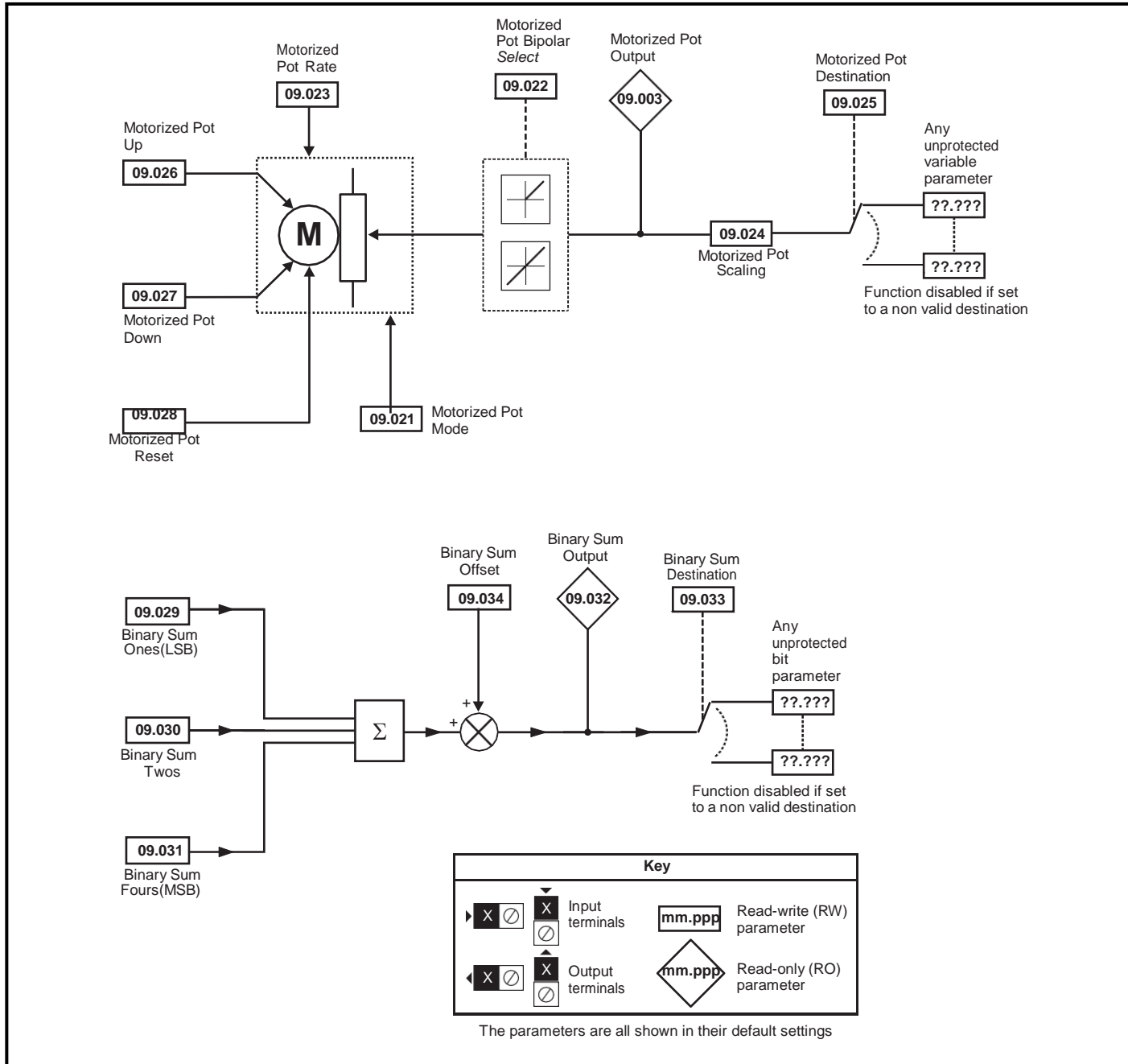
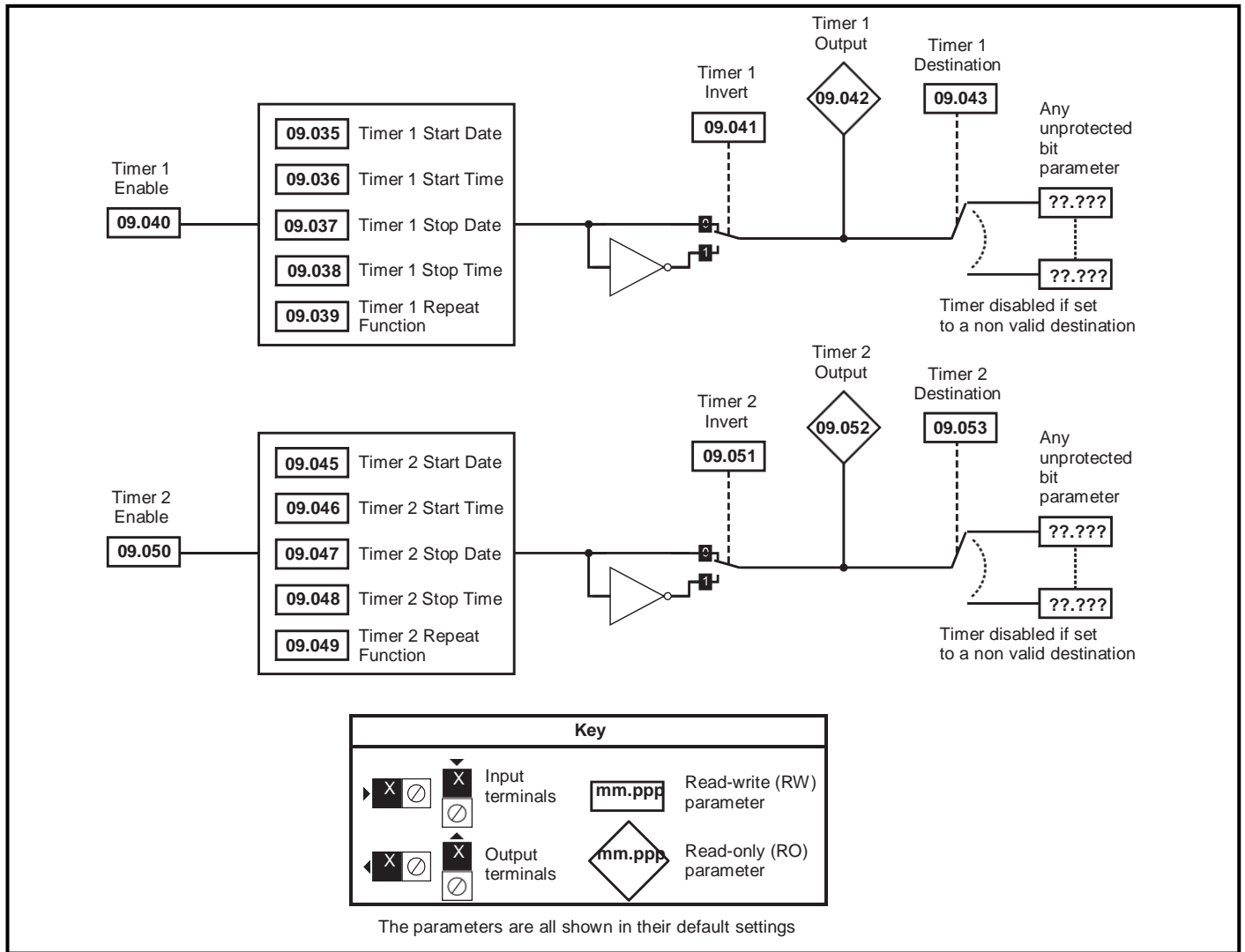
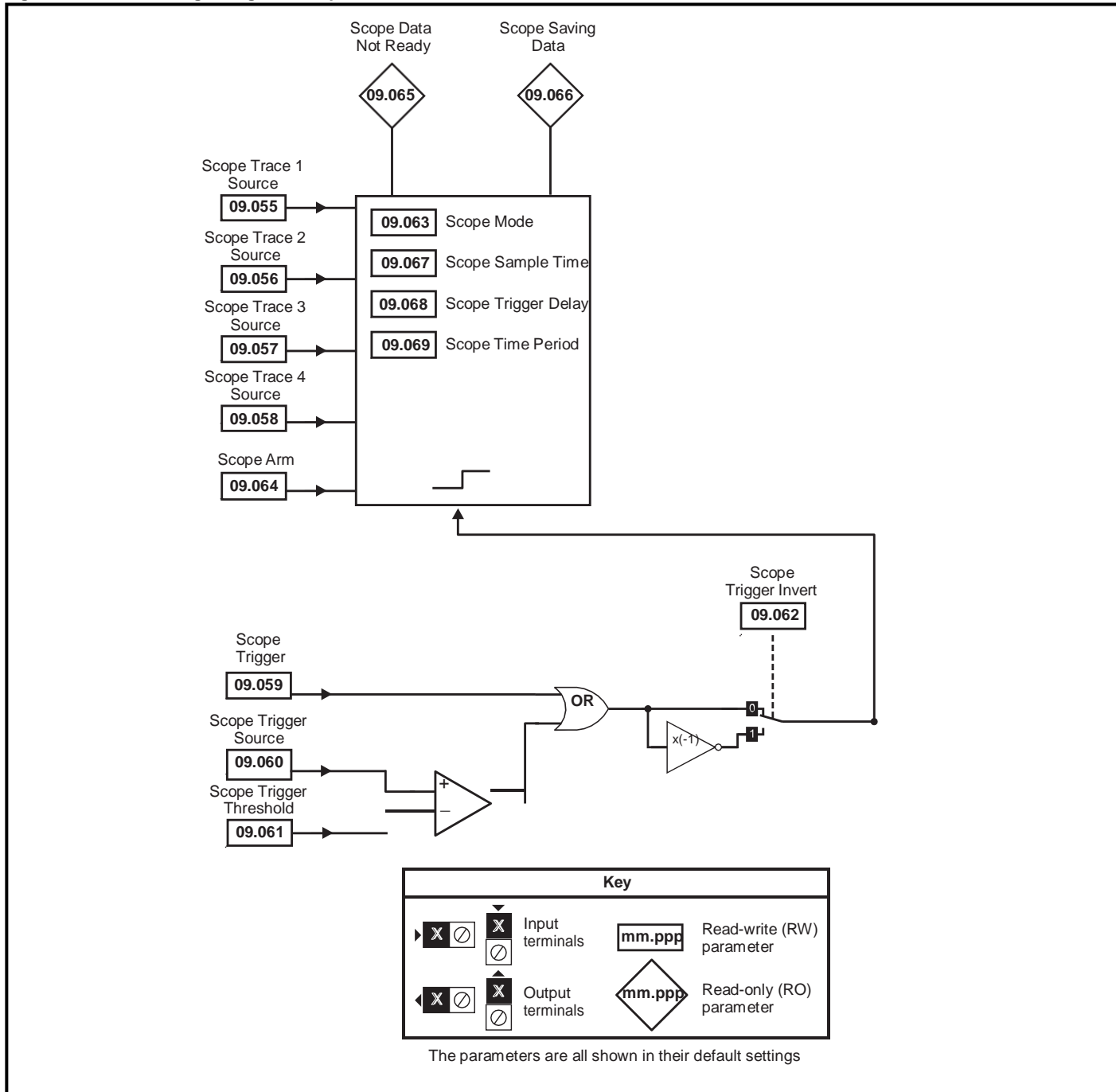

Figure 10-24 Menu 9 logic diagram: Timers



**Figure 10-25 Menu 9 logic diagram: Scope function**



Parameter		Range(⇅)		Default(⇔)			Type					
		OL	RFC-A / S	OL	RFC-A	RFC-S						
09.001	Logic Function 1 Output	Off (0) or On (1)					RO	Bit	ND	NC	PT	
09.002	Logic Function 2 Output	Off (0) or On (1)					RO	Bit	ND	NC	PT	
09.003	Motorized Pot Output	±100.00 %					RO	Num	ND	NC	PT	PS
09.004	Logic Function 1 Source 1	0.000 to 59.999				0.000	RW	Num			PT	US
09.005	Logic Function 1 Source 1 Invert	Off (0) or On (1)				Off (0)	RW	Bit				US
09.006	Logic Function 1 Source 2	0.000 to 59.999				0.000	RW	Num			PT	US
09.007	Logic Function 1 Source 2 Invert	Off (0) or On (1)				Off (0)	RW	Bit				US
09.008	Logic Function 1 Output Invert	Off (0) or On (1)				Off (0)	RW	Bit				US
09.009	Logic Function 1 Delay	±25.0 s				0.0s	RW	Num				US
09.010	Logic Function 1 Destination	0.000 to 59.999				0.000	RW	Num	DE		PT	US
09.014	Logic Function 2 Source 1	0.000 to 59.999				0.000	RW	Num			PT	US
09.015	Logic Function 2 Source 1 Invert	Off (0) or On (1)				Off (0)	RW	Bit				US
09.016	Logic Function 2 Source 2	0.000 to 59.999				0.000	RW	Num			PT	US
09.017	Logic Function 2 Source 2 Invert	Off (0) or On (1)				Off (0)	RW	Bit				US
09.018	Logic Function 2 Output Invert	Off (0) or On (1)				Off (0)	RW	Bit				US
09.019	Logic Function 2 Delay	±25.0 s				0.0 s	RW	Num				US
09.020	Logic Function 2 Destination	0.000 to 59.999				0.000	RW	Num	DE		PT	US
09.021	Motorized Pot Mode	0 to 4				0	RW	Num				US
09.022	Motorized Pot Bipolar Select	Off (0) or On (1)				Off (0)	RW	Bit				US
09.023	Motorized Pot Rate	0 to 250 s				20 s	RW	Num				US
09.024	Motorized Pot Scaling	0.000 to 4.000				1.000	RW	Num				US
09.025	Motorized Pot Destination	0.000 to 59.999				0.000	RW	Num	DE		PT	US
09.026	Motorized Pot Up	Off (0) or On (1)				Off (0)	RW	Bit		NC		
09.027	Motorized Pot Down	Off (0) or On (1)				Off (0)	RW	Bit		NC		
09.028	Motorized Pot Reset	Off (0) or On (1)				Off (0)	RW	Bit		NC		
09.029	Binary Sum Ones	Off (0) or On (1)				Off (0)	RW	Bit		NC		
09.030	Binary Sum Twos	Off (0) or On (1)				Off (0)	RW	Bit		NC		
09.031	Binary Sum Fours	Off (0) or On (1)				Off (0)	RW	Bit		NC		
09.032	Binary Sum Output	0 to 255					RO	Num	ND	NC	PT	
09.033	Binary Sum Destination	0.000 to 59.999				0.000	RW	Num	DE		PT	US
09.034	Binary Sum Offset	0 to 248				0	RW	Num				US
09.035	Timer 1 Start Date	00-00-00 to 31-12-99				00-00-00	RW	Date				US
09.036	Timer 1 Start Time	00:00:00 to 23:59:59				00:00:00	RW	Time				US
09.037	Timer 1 Stop Date	00-00-00 to 31-12-99				00-00-00	RW	Date				US
09.038	Timer 1 Stop Time	00:00:00 to 23:59:59				00:00:00	RW	Time				US
09.039	Timer 1 Repeat Function	None (0), Hour (1), Day (2), Week (3), Month (4), Year (5), One off (6), Minute (7)				None (0)	RW	Txt				US
09.040	Timer 1 Enable	Off (0) or On (1)				Off (0)	RW	Bit				US
09.041	Timer 1 Invert	Off (0) or On (1)				Off (0)	RW	Bit				US
09.042	Timer 1 Output	Off (0) or On (1)					RO	Bit	ND	NC	PT	
09.043	Timer 1 Destination	0.000 to 59.999				0.000	RW	DE			PT	US
09.045	Timer 2 Start Date	00-00-00 to 31-12-99				0	RW	Date				US
09.046	Timer 2 Start Time	00:00:00 to 23:59:59				0	RW	Time				US
09.047	Timer 2 Stop Date	00-00-00 to 31-12-99				0	RW	Date				US
09.048	Timer 2 Stop Time	00:00:00 to 23:59:59				0	RW	Time				US
09.049	Timer 2 Repeat Function	None (0), Hour (1), Day (2), Week (3), Month (4), Year (5), One off (6), Minute (7)				None (0)	RW	Txt				US
09.050	Timer 2 Enable	Off (0) or On (1)				Off (0)	RW	Bit				US
09.051	Timer 2 Invert	Off (0) or On (1)				Off (0)	RW	Bit				US
09.052	Timer 2 Output	Off (0) or On (1)					RO	Bit	ND	NC	PT	
09.053	Timer 2 Destination	0.000 to 59.999				0.000	RW	DE			PT	US
09.055	Scope Trace 1 Source	0.000 to 59.999				0.000	RW	Num			PT	US
09.056	Scope Trace 2 Source	0.000 to 59.999				0.000	RW	Num			PT	US
09.057	Scope Trace 3 Source	0.000 to 59.999				0.000	RW	Num			PT	US
09.058	Scope Trace 4 Source	0.000 to 59.999				0.000	RW	Num			PT	US
09.059	Scope Trigger	Off (0) or On (1)				Off (0)	RW	Bit				US
09.060	Scope Trigger Source	0.000 to 59.999				0.000	RW	Num			PT	US

Safety information	Product information	Electrical installation	Getting started	Basic parameters	Running the motor	Optimization	NV Media Card Operation	Onboard PLC	<b>Advanced parameters</b>	Technical data	Diagnostics	UL listing information
--------------------	---------------------	-------------------------	-----------------	------------------	-------------------	--------------	-------------------------	-------------	----------------------------	----------------	-------------	------------------------

Parameter	Range(↕)		Default(⇔)			Type					
	OL	RFC-A / S	OL	RFC-A	RFC-S						
09.061	Scope Trigger Threshold	-2147483648 to 2147483647	0			RW	Num				US
09.062	Scope Trigger Invert	Off (0) or On (1)	Off (0)			RW	Bit				US
09.063	Scope Mode	Single (0), Normal (1), Auto (2)	Single (0)			RW	Txt				US
09.064	Scope Arm	Off (0) or On (1)	Off (0)			RW	Bit		NC		
09.065	Scope Data Not Ready	Off (0) or On (1)				RO	Bit	ND	NC	PT	
09.066	Scope Saving Data	Off (0) or On (1)				RO	Bit	ND	NC	PT	
09.067	Scope Sample Time	1 to 200	1			RW	Num				US
09.068	Scope Trigger Delay	0 to 100 %	0 %			RW	Num				US
09.069	Scope Time Period	0.00 to 200000.00 ms				RO	Num	ND	NC	PT	
09.070	Scope Auto-save Mode	Disabled (0), Overwrite (1), Keep (2)	Disabled (0)			RW	Txt				US
09.071	Scope Auto-save File Number	0 to 99	0			RO	Num				PS
09.072	Scope Auto-save Reset	Off (0) or On (1)	Off (0)			RW	Bit				
09.073	Scope Auto-save Status	Disabled (0), Active (1), Stopped (2), Failed (3)	Disabled (0)			RO	Txt				PS

RW	Read / Write	RO	Read only	Num	Number parameter	Bit	Bit parameter	Txt	Text string	Bin	Binary parameter	FI	Filtered
ND	No default value	NC	Not copied	PT	Protected parameter	RA	Rating dependent	US	User save	PS	Power-down save	DE	Destination
IP	IP address	Mac	Mac address	Date	Date parameter	Time	Time parameter	SMP	Slot,menu,parameter	Chr	Character parameter	Ver	Version number

## 10.10 Menu 10: Status and trips

Parameter		Range(⇅)		Default(⇌)			Type					
		OL	RFC-A / S	OL	RFC-A	RFC-S						
10.001	Drive OK	Off (0) or On (1)					RO	Bit	ND	NC	PT	
10.002	Drive Active	Off (0) or On (1)					RO	Bit	ND	NC	PT	
10.003	Zero Speed	Off (0) or On (1)					RO	Bit	ND	NC	PT	
10.004	Running At Or Below Minimum Speed	Off (0) or On (1)					RO	Bit	ND	NC	PT	
10.005	Below Set Speed	Off (0) or On (1)					RO	Bit	ND	NC	PT	
10.006	At Speed	Off (0) or On (1)					RO	Bit	ND	NC	PT	
10.007	Above Set Speed	Off (0) or On (1)					RO	Bit	ND	NC	PT	
10.008	Rated Load Reached	Off (0) or On (1)					RO	Bit	ND	NC	PT	
10.009	Current Limit Active	Off (0) or On (1)					RO	Bit	ND	NC	PT	
10.010	Regenerating	Off (0) or On (1)					RO	Bit	ND	NC	PT	
10.011	Braking IGBT Active	Off (0) or On (1)					RO	Bit	ND	NC	PT	
10.012	Braking Resistor Alarm	Off (0) or On (1)					RO	Bit	ND	NC	PT	
10.013	Reverse Direction Commanded	Off (0) or On (1)					RO	Bit	ND	NC	PT	
10.014	Reverse Direction Running	Off (0) or On (1)					RO	Bit	ND	NC	PT	
10.015	Supply Loss	Off (0) or On (1)					RO	Bit	ND	NC	PT	
10.016	Under Voltage Active	Off (0) or On (1)					RO	Bit	ND	NC	PT	
10.017	Motor Overload Alarm	Off (0) or On (1)					RO	Bit	ND	NC	PT	
10.018	Drive Over-temperature Alarm	Off (0) or On (1)					RO	Bit	ND	NC	PT	
10.019	Drive Warning	Off (0) or On (1)					RO	Bit	ND	NC	PT	
10.020	Trip 0	0 to 255					RO	Txt	ND	NC	PT	PS
10.021	Trip 1	0 to 255					RO	Txt	ND	NC	PT	PS
10.022	Trip 2	0 to 255					RO	Txt	ND	NC	PT	PS
10.023	Trip 3	0 to 255					RO	Txt	ND	NC	PT	PS
10.024	Trip 4	0 to 255					RO	Txt	ND	NC	PT	PS
10.025	Trip 5	0 to 255					RO	Txt	ND	NC	PT	PS
10.026	Trip 6	0 to 255					RO	Txt	ND	NC	PT	PS
10.027	Trip 7	0 to 255					RO	Txt	ND	NC	PT	PS
10.028	Trip 8	0 to 255					RO	Txt	ND	NC	PT	PS
10.029	Trip 9	0 to 255					RO	Txt	ND	NC	PT	PS
10.030	Braking Resistor Rated Power	0.000 to 99999.999 kW				See Table 10-5	RW	Num				US
10.031	Braking Resistor Thermal Time Constant	0.000 to 1500.000 s				See Table 10-5	RW	Num				US
10.032	External Trip	Off (0) or On (1)				Off (0)	RW	Bit		NC		
10.033	Drive Reset	Off (0) or On (1)				Off (0)	RW	Bit		NC		
10.034	Number Of Auto-reset Attempts	None (0), 1 (1), 2 (2), 3 (3), 4 (4), 5 (5), Infinite (6)				None (0)	RW	Txt				US
10.035	Auto-reset Delay	0.0 to 600.0 s				1.0 s	RW	Num				US
10.036	Auto-reset Hold Drive ok	Off (0) or On (1)				Off (0)	RW	Bit				US
10.037	Action On Trip Detection	00000 to 11111				00000	RW	Bin				US
10.038	User Trip	0 to 255					RW	Num	ND	NC		
10.039	Braking Resistor Thermal Accumulator	0.0 to 100.0 %					RO	Num	ND	NC	PT	
10.040	Status Word	0000000000000000 to 1111111111111111					RO	Bin	ND	NC	PT	
10.041	Trip 0 Date	00-00-00 to 31-12-99					RO	Date	ND	NC	PT	PS
10.042	Trip 0 Time	00:00:00 to 23:59:59					RO	Time	ND	NC	PT	PS
10.043	Trip 1 Date	00-00-00 to 31-12-99					RO	Date	ND	NC	PT	PS
10.044	Trip 1 Time	00:00:00 to 23:59:59					RO	Time	ND	NC	PT	PS
10.045	Trip 2 Date	00-00-00 to 31-12-99					RO	Date	ND	NC	PT	PS
10.046	Trip 2 Time	00:00:00 to 23:59:59					RO	Time	ND	NC	PT	PS
10.047	Trip 3 Date	00-00-00 to 31-12-99					RO	Date	ND	NC	PT	PS
10.048	Trip 3 Time	00:00:00 to 23:59:59					RO	Time	ND	NC	PT	PS
10.049	Trip 4 Date	00-00-00 to 31-12-99					RO	Date	ND	NC	PT	PS
10.050	Trip 4 Time	00:00:00 to 23:59:59					RO	Time	ND	NC	PT	PS
10.051	Trip 5 Date	00-00-00 to 31-12-99					RO	Date	ND	NC	PT	PS
10.052	Trip 5 Time	00:00:00 to 23:59:59					RO	Time	ND	NC	PT	PS
10.053	Trip 6 Date	00-00-00 to 31-12-99					RO	Date	ND	NC	PT	PS
10.054	Trip 6 Time	00:00:00 to 23:59:59					RO	Time	ND	NC	PT	PS
10.055	Trip 7 Date	00-00-00 to 31-12-99					RO	Date	ND	NC	PT	PS
10.056	Trip 7 Time	00:00:00 to 23:59:59					RO	Time	ND	NC	PT	PS
10.057	Trip 8 Date	00-00-00 to 31-12-99					RO	Date	ND	NC	PT	PS

Parameter		Range(⇅)		Default(⇄)			Type					
		OL	RFC-A / S	OL	RFC-A	RFC-S						
10.058	Trip 8 Time	00:00:00 to 23:59:59					RO	Time	ND	NC	PT	PS
10.059	Trip 9 Date	00-00-00 to 31-12-99					RO	Date	ND	NC	PT	PS
10.060	Trip 9 Time	00:00:00 to 23:59:59					RO	Time	ND	NC	PT	PS
10.061	Braking Resistor Resistance	0.00 to 10000.00 Ω		See Table 10-5			RW	Num				US
10.062	Low Load Detected Alarm	Off (0) or On (1)					RO	Bit	ND	NC	PT	
10.063	Local Keypad Battery Low	Off (0) or On (1)					RO	Bit	ND	NC	PT	
10.064	Remote Keypad Battery Low	Off (0) or On (1)					RO	Bit	ND	NC	PT	
10.065	Auto-tune Active	Off (0) or On (1)					RO	Bit	ND	NC	PT	
10.066	Limit Switch Active	Off (0) or On (1)					RO	Bit	ND	NC	PT	
10.068	Hold Drive OK On Under Voltage	Off (0) or On (1)		Off (0)			RW	Bit				US
10.069	Additional Status Bits	000000000 to 111111111					RO	Bin	ND	NC	PT	
10.070	Trip 0 Sub-trip Number	0 to 65535					RO	Num	ND	NC	PT	PS
10.071	Trip 1 Sub-trip Number	0 to 65535					RO	Num	ND	NC	PT	PS
10.072	Trip 2 Sub-trip Number	0 to 65535					RO	Num	ND	NC	PT	PS
10.073	Trip 3 Sub-trip Number	0 to 65535					RO	Num	ND	NC	PT	PS
10.074	Trip 4 Sub-trip Number	0 to 65535					RO	Num	ND	NC	PT	PS
10.075	Trip 5 Sub-trip Number	0 to 65535					RO	Num	ND	NC	PT	PS
10.076	Trip 6 Sub-trip Number	0 to 65535					RO	Num	ND	NC	PT	PS
10.077	Trip 7 Sub-trip Number	0 to 65535					RO	Num	ND	NC	PT	PS
10.078	Trip 8 Sub-trip Number	0 to 65535					RO	Num	ND	NC	PT	PS
10.079	Trip 9 Sub-trip Number	0 to 65535					RO	Num	ND	NC	PT	PS
10.080	Stop Motor	Off (0) or On (1)					RO	Bit	ND	NC	PT	
10.081	Phase Loss	Off (0) or On (1)					RO	Bit	ND	NC	PT	
10.101	Drive Status	Inhibit (0), Ready (1), Stop (2), Scan (3), Run (4), Supply Loss (5), Deceleration (6), dc Injection (7), Position (8), Trip (9), Active (10), Off (11), Hand (12), Auto (13), Heat (14), Under Voltage (15)					RO	Txt	ND	NC	PT	
10.102	Trip Reset Source	0 to 1023					RO	Num	ND	NC	PT	PS
10.103	Trip Time Identifier	-2147483648 to 2147483647 ms					RO	Num	ND	NC	PT	
10.104	Active Alarm	None (0), Brake Resistor (1), Motor Overload (2), Ind Overload (3), Drive Overload (4), Auto Tune (5), Limit Switch (6), Fire Mode (7), Low Load (8), Option Slot 1 (9), Option Slot 2 (10), Option Slot 3 (11), Option Slot 4 (12)					RO	Txt	ND	NC	PT	
10.105	Hand Off Auto State	Not Active (0), Off (1), Hand (2), Auto (3)					RO	Txt	ND	NC	PT	PS
10.106	Potential Drive Damage Conditions	0000 to 1111					RO	Bin	ND	NC	PT	PS

RW	Read / Write	RO	Read only	Num	Number parameter	Bit	Bit parameter	Txt	Text string	Bin	Binary parameter	FI	Filtered
ND	No default value	NC	Not copied	PT	Protected parameter	RA	Rating dependent	US	User save	PS	Power-down save	DE	Destination
IP	IP address	Mac	Mac address	Date	Date parameter	Time	Time parameter	SMP	Slot,menu,parameter	Chr	Character parameter	Ver	Version number

Table 10-5 Defaults for Pr 10.030, Pr 10.031 and Pr 10.061

Drive size	Pr 10.030	Pr 10.031	Pr 10.061
Size 3	50 W	3.3 s	75 Λ
Size 4 and 5	100 W	2.0 s	38 Λ
All other ratings and frame sizes	0.000		0.00

## 10.11 Menu 11: General drive set-up

Parameter		Range(⇅)		Default(⇄)			Type						
		OL	RFC-A / S	OL	RFC-A	RFC-S							
11.001	Option Synchronisation Select		Not Active (0), Slot 1 (1), Slot 2 (2), Slot 3 (3), Slot 4 (4), Automatic (5)		Slot 4 (4)							US	
11.002	Option synchronisation Active		Not Active (0), Slot 1 (1), Slot 2 (2), Slot 3 (3), Slot 4 (4)										
11.018	Status Mode Parameter 1	0.000 to 59.999		0.000			RW	Num				PT	US
11.019	Status Mode Parameter 2	0.000 to 59.999		0.000			RW	Num				PT	US
11.020	Reset Serial Communications*	Off (0) or On (1)					RW	Bit	ND	NC			
11.021	Parameter 00.030 Scaling	0.000 to 10.000		1.000			RW	Num				US	
11.022	Parameter Displayed At Power-up	0.000 to 0.080		0.010			RW	Num				US	
11.023	Serial Address*	1 to 247		1			RW	Num				US	
11.024	Serial Mode*	8 2 NP (0), 8 1 NP (1), 8 1 EP (2), 8 1 OP (3), 8 2 NP M (4), 8 1 NP M (5), 8 1 EP M (6), 8 1 OP M (7), 7 2 NP (8), 7 1 NP (9), 7 1 EP (10), 7 1 OP (11), 7 2 NP M (12), 7 1 NP M (13), 7 1 EP M (14), 7 1 OP M (15)		8 2 NP (0)			RW	Txt					US
11.025	Serial Baud Rate*	300 (0), 600 (1), 1200 (2), 2400 (3), 4800 (4), 9600 (5), 19200 (6), 38400 (7), 57600 (8), 76800 (9), 115200 (10)		19200 (6)			RW	Txt					US
11.026	Minimum Comms Transmit Delay*	0 to 250 ms		2 ms			RW	Num				US	
11.027	Silent Period*	0 to 250 ms		0 ms			RW	Num				US	
11.028	Drive Derivative	0 to 255					RO	Num	ND	NC	PT		
11.029	Software Version	00.00.00.00 to 99.99.99.99					RO	Num	ND	NC	PT		
11.030	User Security Code	0 to 2147483647					RW	Num	ND	NC	PT	US	
11.031	User Drive Mode	Open-loop (1), RFC-A (2), RFC-S (3), Regen (4)					RW	Txt	ND	NC	PT		
11.032	Maximum Heavy Duty Rating	0.000 to 99999.999					RO	Num	ND	NC	PT		
11.033	Drive Rated Voltage	200 V (0), 400 V (1), 575 V (2), 690 V (3)					RO	Txt	ND	NC	PT		
11.034	Software Sub Version	0 to 99					RO	Num	ND	NC	PT		
11.035	Number Of Power Modules Test	-1 to 32		-1			RW	Num				US	
11.036	NV Media Card File Previously Loaded	0 to 999		0			RO	Num		NC	PT		
11.037	NV Media Card File Number	0 to 999		0			RW	Num					
11.038	NV Media Card File Type	None (0), Open-loop (1), RFC-A (2), RFC-S (3), Regen (4), User Prog (5), Option App (6)					RO	Txt	ND	NC	PT		
11.039	NV Media Card File Version	0 to 9999					RO	Num	ND	NC	PT		
11.040	NV Media Card File Checksum	--2147483648 to 2147483647					RO	Num	ND	NC	PT		
11.042	Parameter Cloning	None (0), Read (1), Program (2), Auto (3), Boot (4)		None (0)			RW	Txt		NC		US	
11.043	Load Defaults	None (0), Standard (1), US (2)		None (0)			RW	Txt		NC			
11.044	User Security Status	Menu 0 (0), All Menus (1), Read-only Menu 0 (2), Read-only (3), Status Only (4), No Access (5)					RW	Txt	ND		PT		
11.045	Select Motor 2 Parameters	Motor 1 (0) or Motor 2 (1)		Motor 1 (0)			RW	Txt				US	
11.046	Defaults Previously Loaded	0 to 2000					RO	Num	ND	NC	PT	US	
11.047	Onboard User Program: Enable	Stop (0) or Run (1)		Run (1)			RW	Txt				US	
11.048	Onboard User Program: Status	-2147483648 to 2147483647					RO	Num	ND	NC	PT		
11.049	Onboard User Program: Programming Events	0 to 65535					RO	Num	ND	NC	PT		
11.050	Onboard User Program: Freewheeling Tasks Per Second	0 to 65535					RO	Num	ND	NC	PT		
11.051	Onboard User Program: Clock Task Time Used	0.0 to 100.0 %					RO	Num	ND	NC	PT		
11.052	Serial Number LS	000000000 to 999999999					RO	Num	ND	NC	PT		
11.053	Serial Number MS	0 to 999999999					RO	Num	ND	NC	PT		
11.054	Drive Date Code	0 to 65535					RO	Num	ND	NC	PT		
11.055	Onboard User Program: Clock Task Scheduled Interval	0 to 262140 ms					RO	Num	ND	NC	PT		
11.056	Option Slot Identifiers	1234 (0), 1243 (1), 1324 (2), 1342 (3), 1423 (4), 1432 (5), 4123 (6), 3124 (7), 4132 (8), 2134 (9), 3142 (10), 2143 (11), 3412 (12), 4312 (13), 2413 (14), 4213 (15), 2314 (16), 3214 (17), 2341 (18), 2431 (19), 3241 (20), 3421 (21), 4231 (22), 4321 (23)		1234 (0)			RW	Txt				PT	
11.060	Maximum Rated Current	0.000 to 99999.999					RO	Num	ND	NC	PT		

Parameter	Range(⇅)		Default(⇔)			Type					
	OL	RFC-A / S	OL	RFC-A	RFC-S	RO	Num	ND	NC	PT	US
11.061	Full Scale Current Kc	0.000 to 99999.999				RO	Num	ND	NC	PT	
11.063	Product Type	0 to 255				RO	Num	ND	NC	PT	
11.064	Product Identifier Characters	HS70 / HS71 / HS72				RO	Chr	ND	NC	PT	
11.065	Drive Rating And Configuration	0 to 999999999				RO	Num	ND	NC	PT	
11.066	Power Stage Identifier	0 to 255				RO	Num	ND	NC	PT	
11.067	Control Board Identifier	0.000 to 65.535				RO	Num	ND	NC	PT	
11.068	Internal I/O Identifier	0 to 255				RO	Num	ND	NC	PT	
11.069	Position Feedback Interface Identifier	0 to 255				RO	Num	ND	NC	PT	
11.070	Core Parameter Database Version	0.00 to 99.99				RO	Num	ND	NC	PT	
11.071	Number Of Power Modules Detected	0 to 32				RO	Num	ND	NC	PT	US
11.072	NV Media Card Create Special File	0 to 1			0	RW	Num		NC		
11.073	NV Media Card Type	None (0), SMART Card (1), SD Card (2)				RO	Txt	ND	NC	PT	
11.075	NV Media Card Read-only Flag	Off (0) or On (1)				RO	Bit	ND	NC	PT	
11.076	NV Media Card Warning Suppression Flag	Off (0) or On (1)				RO	Bit	ND	NC	PT	
11.077	NV Media Card File Required Version	0 to 9999				RW	Num	ND	NC	PT	
11.079	Drive Name Characters 1-4	(-2147483648) to (2147483647)			(0)	RW	Chr			PT	US
11.080	Drive Name Characters 5-8	(-2147483648) to (2147483647)			(0)	RW	Chr			PT	US
11.081	Drive Name Characters 9-12	(-2147483648) to (2147483647)			(0)	RW	Chr			PT	US
11.082	Drive Name Characters 13-16	(-2147483648) to (2147483647)			(0)	RW	Chr			PT	US
11.084	Drive Mode	Open-loop (1), RFC-A (2), RFC-S (3), Regen (4)				RO	Txt	ND	NC	PT	US
11.085	Security Status	None (0), Read-only (1), Status-only (2), No Access (3)				RO	Txt	ND	NC	PT	PS
11.086	Menu Access Status	Menu 0 (0) or All Menus (1)				RO	Txt	ND	NC	PT	PS
11.090	Keypad Port Serial Address	1 to 16			1	RW	Num				US
11.091	Additional Identifier Characters 1	(-2147483648) to (2147483647)				RO	Chr	ND	NC	PT	
11.092	Additional Identifier Characters 2	(-2147483648) to (2147483647)				RO	Chr	ND	NC	PT	
11.093	Additional Identifier Characters 3	(-2147483648) to (2147483647)				RO	Chr	ND	NC	PT	

\* On Unidrive HS71 only.

RW	Read / Write	RO	Read only	Num	Number parameter	Bit	Bit parameter	Txt	Text string	Bin	Binary parameter	FI	Filtered
ND	No default value	NC	Not copied	PT	Protected parameter	RA	Rating dependent	US	User save	PS	Power-down save	DE	Destination
IP	IP address	Mac	Mac address	Date	Date parameter	Time	Time parameter	SMP	Slot,menu,parameter	Chr	Character parameter	Ver	Version number

## 10.12 Menu 12: Threshold detectors, variable selectors and brake control function

Figure 10-26 Menu 12 logic diagram

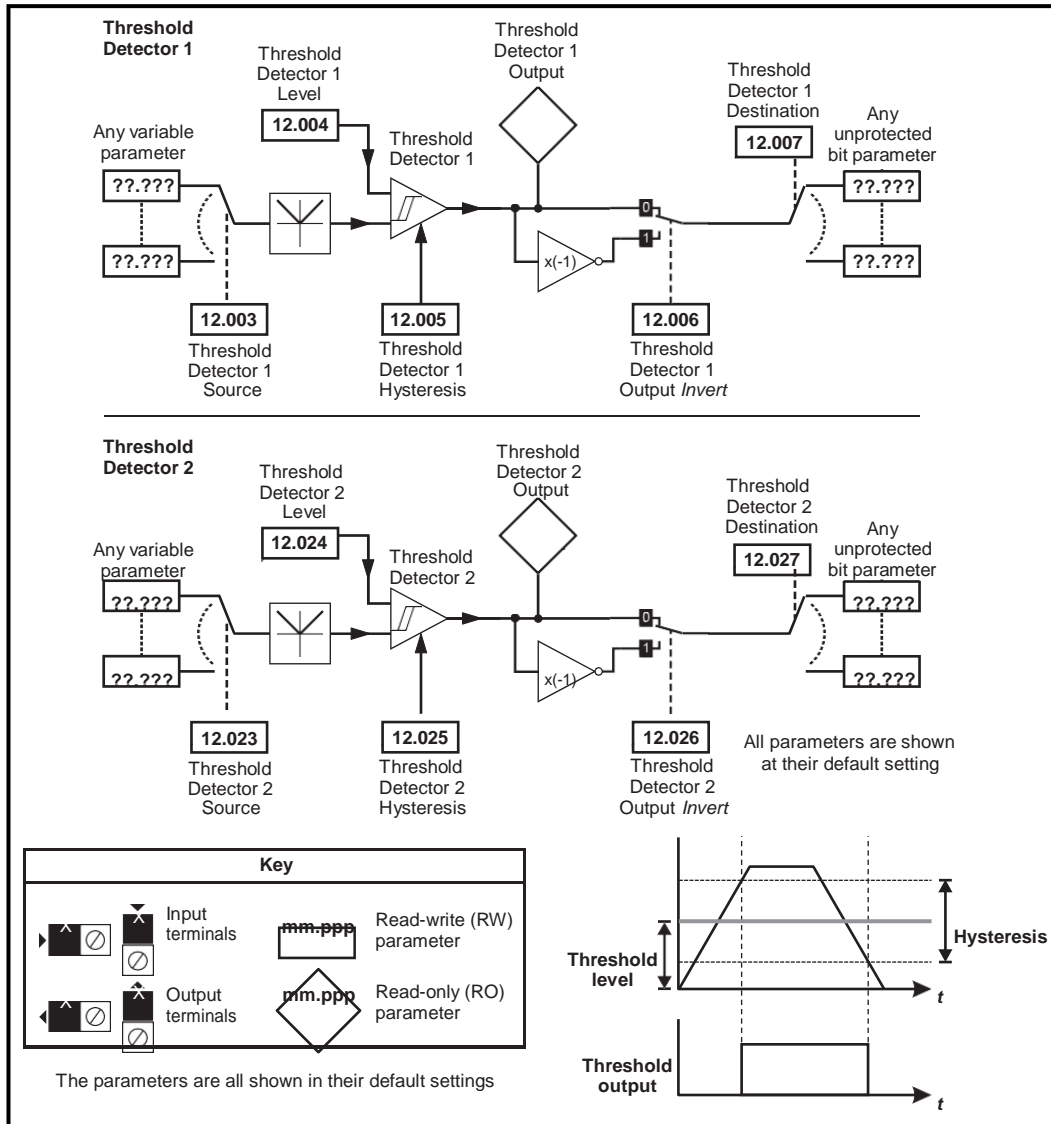

**Figure 10-27 Menu 12 logic diagram (continued)**

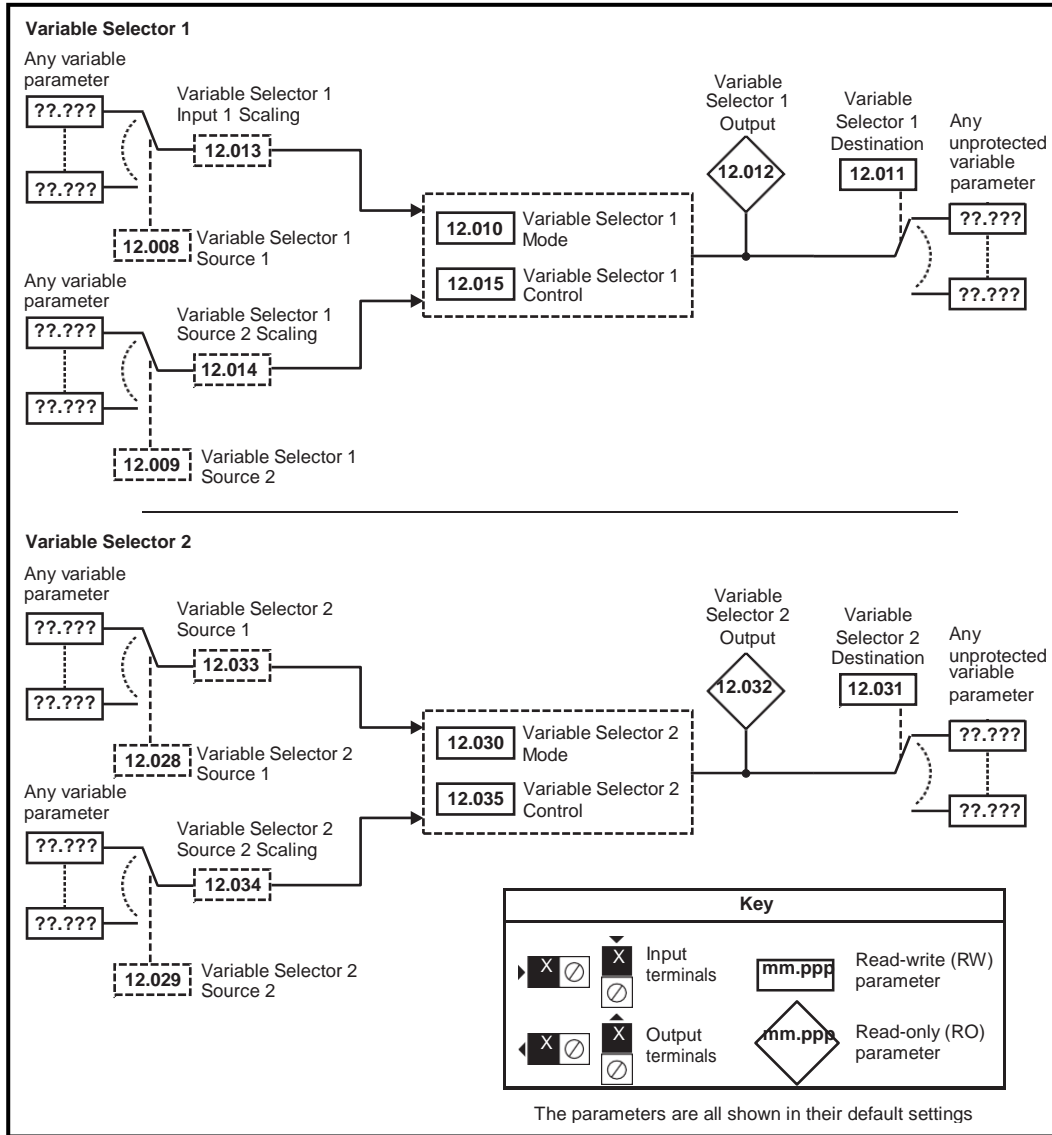



The brake control functions are provided to allow well co-ordinated operation of an external brake with the drive. While both hardware and software are designed to high standards of quality and robustness, they are not intended for use as safety functions, i.e. where a fault or failure would result in a risk of injury. In any application where the incorrect operation of the brake release mechanism could result in injury, independent protection devices of proven integrity must also be incorporated.



The control terminal relay can be selected as an output to release a brake. If a drive is set up in this manner and a drive replacement takes place, prior to programming the drive on initial power up, the brake may be released. When drive terminals are programmed to non default settings the result of incorrect or delayed programming must be considered. The use of a NV media card in boot mode or an SI-Applications module can ensure drive parameters are immediately programmed to avoid this situation.

**Figure 10-28 Open-loop brake function**

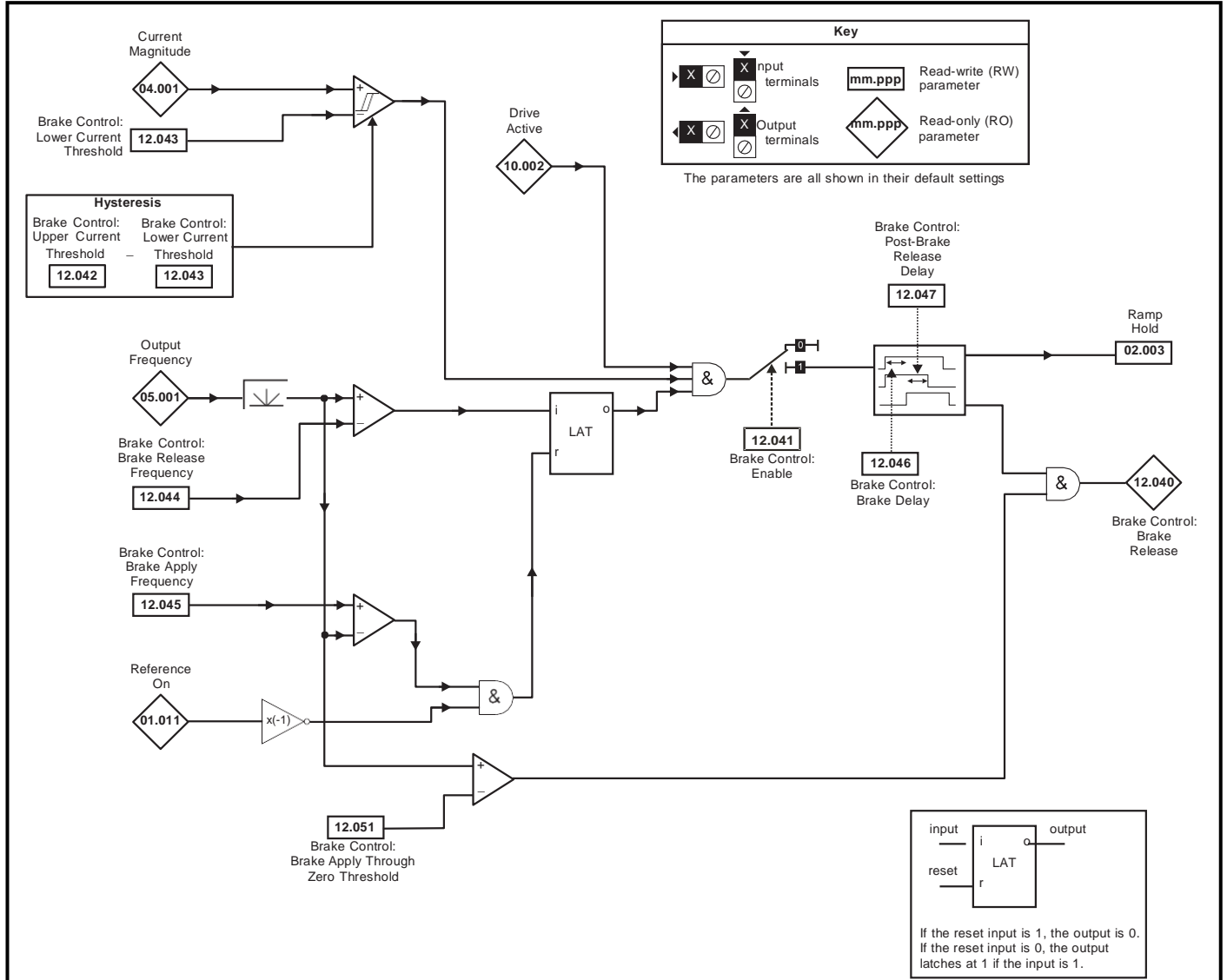

**Figure 10-29 Open-loop brake sequence**

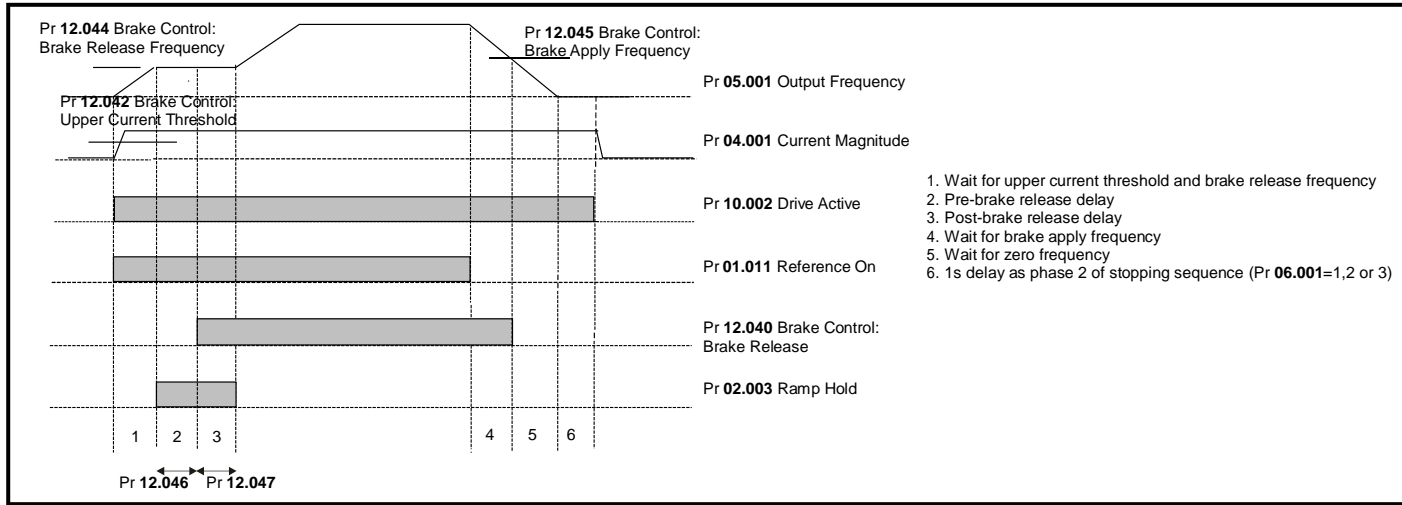



The brake control functions are provided to allow well co-ordinated operation of an external brake with the drive. While both hardware and software are designed to high standards of quality and robustness, they are not intended for use as safety functions, i.e. where a fault or failure would result in a risk of injury. In any application where the incorrect operation of the brake release mechanism could result in injury, independent protection devices of proven integrity must also be incorporated.



The control terminal relay can be selected as an output to release a brake. If a drive is set up in this manner and a drive replacement takes place, prior to programming the drive on initial power up, the brake may be released. When drive terminals are programmed to non default settings the result of incorrect or delayed programming must be considered. The use of a NV media card in boot mode or an SI-Applications module can ensure drive parameters are immediately programmed to avoid this situation.

**Figure 10-30 RFC-A mode (brake controller (12.052) = 0) and RFC-S mode**

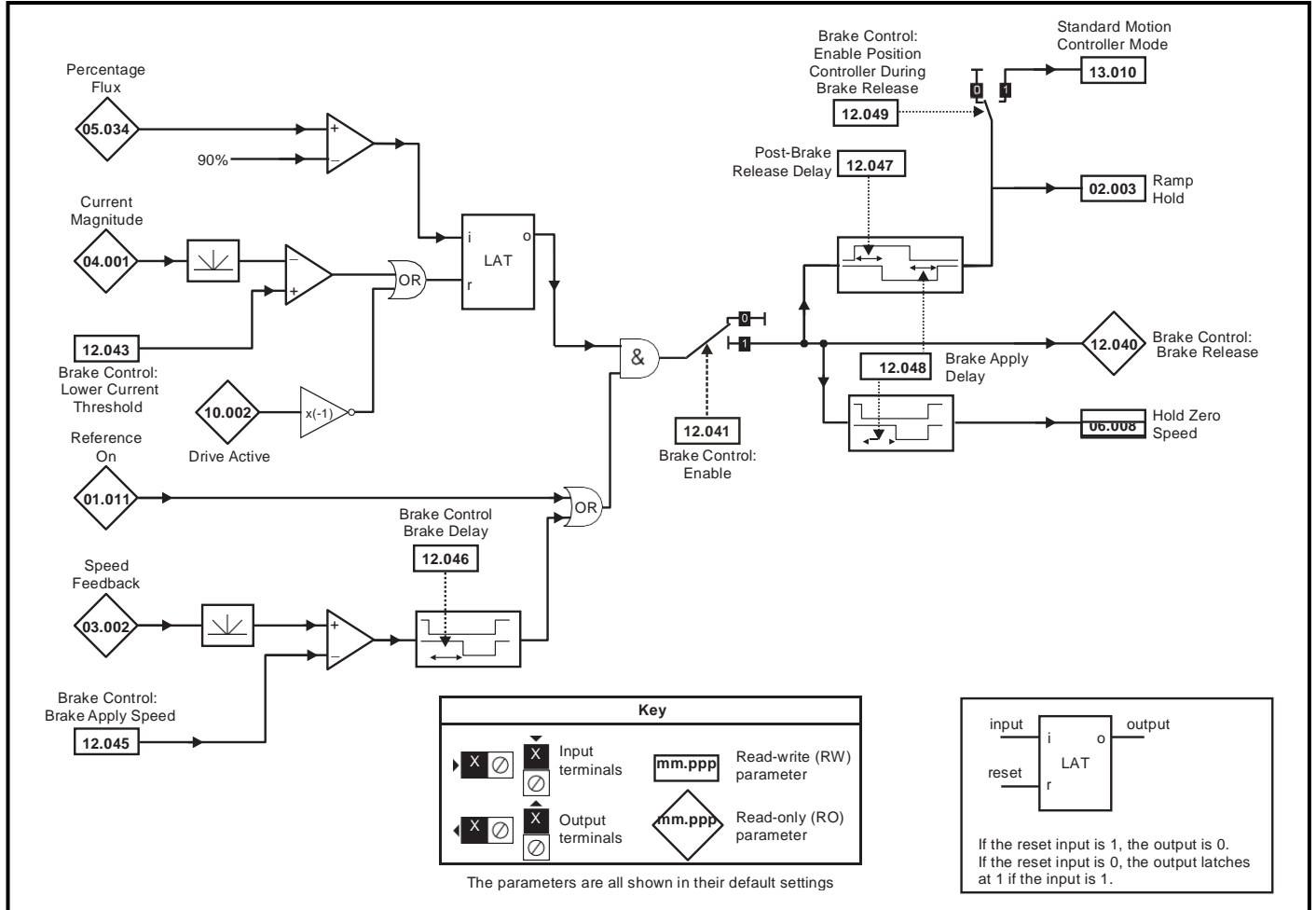

**Figure 10-31 RFC-A brake sequence**

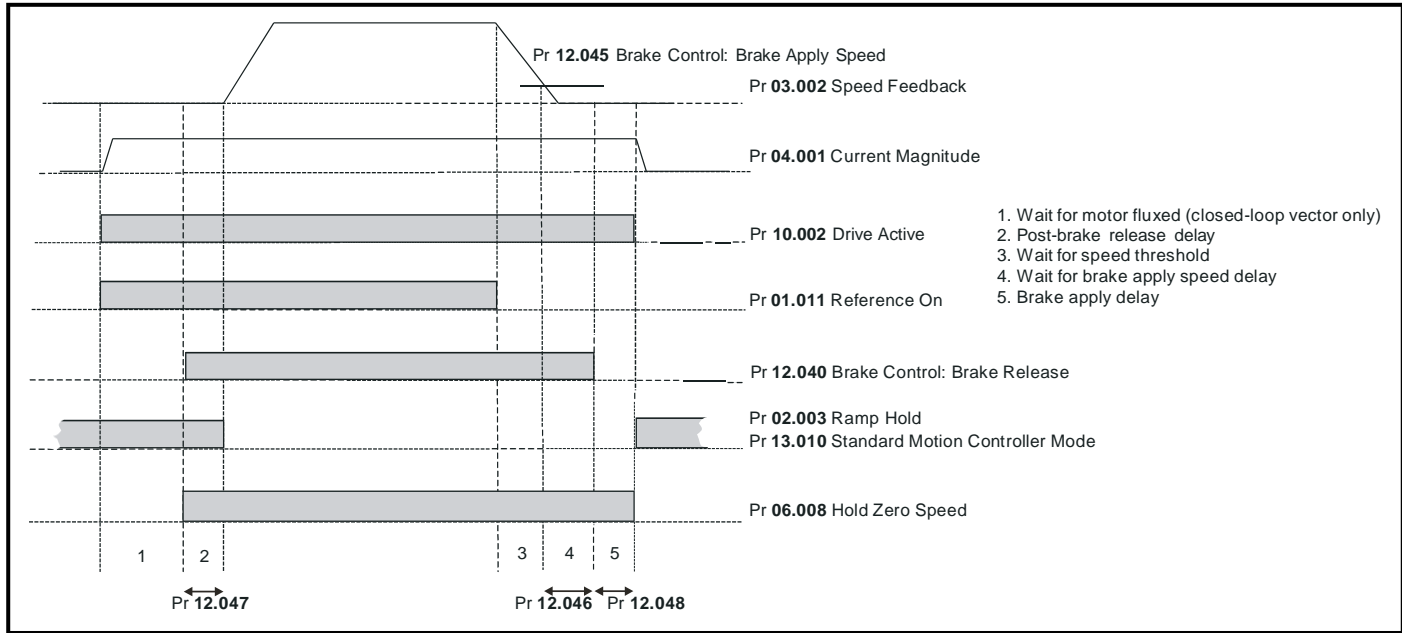



The brake control functions are provided to allow well co-ordinated operation of an external brake with the drive. While both hardware and software are designed to high standards of quality and robustness, they are not intended for use as safety functions, i.e. where a fault or failure would result in a risk of injury. In any application where the incorrect operation of the brake release mechanism could result in injury, independent protection devices of proven integrity must also be incorporated.



The control terminal relay can be selected as an output to release a brake. If a drive is set up in this manner and a drive replacement takes place, prior to programming the drive on initial power up, the brake may be released. When drive terminals are programmed to non default settings the result of incorrect or delayed programming must be considered. The use of a NV media card in boot mode or an SI-Applications module can ensure drive parameters are immediately programmed to avoid this situation.

**Figure 10-32 RFC-A mode with brake controller mode (12.052) =1**

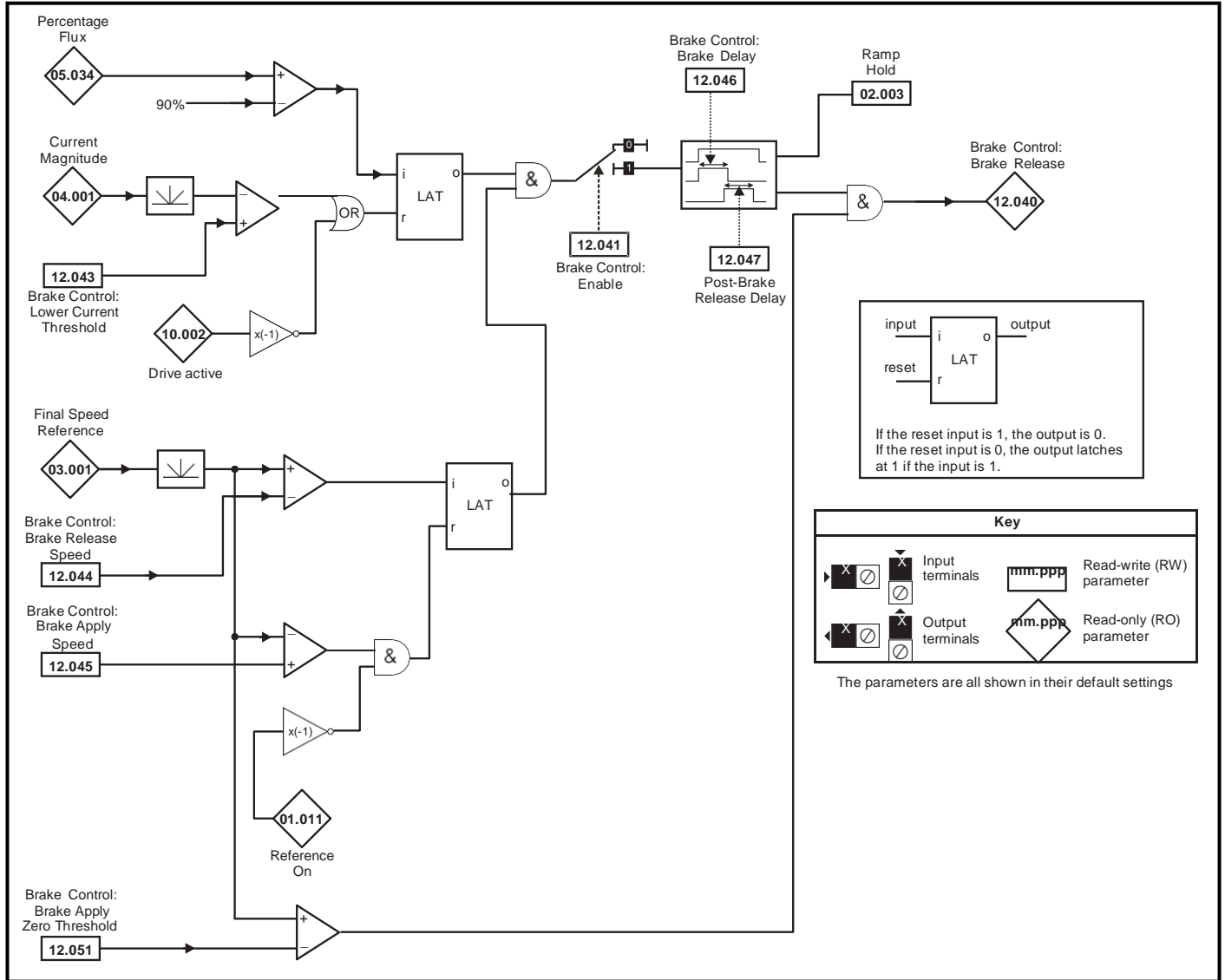

Parameter	Range(⇅)			Default(⇄)			Type						
	OL	RFC- A	RFC- A	OL	RFC-A	RFC-S							
12.001	Threshold Detector 1 Output	Off (0) or On (1)						RO	Bit	ND	NC	PT	
12.002	Threshold Detector 2 Output	Off (0) or On (1)						RO	Bit	ND	NC	PT	
12.003	Threshold Detector 1 Source	0.000 to 59.999			0.000			RW	Num			PT	US
12.004	Threshold Detector 1 Level	0.00 to 100.00 %			0.00 %			RW	Num				US
12.005	Threshold Detector 1 Hysteresis	0.00 to 25.00 %			0.00 %			RW	Num				US
12.006	Threshold Detector 1 Output Invert	Off (0) or On (1)			Off (0)			RW	Bit				US
12.007	Threshold Detector 1 Destination	0.000 to 59.999			0.000			RW	Num	DE		PT	US
12.008	Variable Selector 1 Source 1	0.000 to 59.999			0.000			RW	Num			PT	US
12.009	Variable Selector 1 Source 2	0.000 to 59.999			0.000			RW	Num			PT	US
12.010	Variable Selector 1 Mode	Input 1 (0), Input 2 (1), Add (2), Subtract (3), Multiply (4), Divide (5), Time Const (6), Ramp (7), Modulus (8), Powers (9), Sectional (10)			Input 1 (0)			RW	Txt				US
12.011	Variable Selector 1 Destination	0.000 to 59.999			0.000			RW	Num	DE		PT	US
12.012	Variable Selector 1 Output	±100.00 %						RO	Num	ND	NC	PT	
12.013	Variable Selector 1 Source 1 Scaling	±4.000			1.000			RW	Num				US
12.014	Variable Selector 1 Source 2 Scaling	±4.000			1.000			RW	Num				US
12.015	Variable Selector 1 Control	0.00 to 100.00			0.00			RW	Num				US
12.016	Variable Selector 1 Enable	Off (0) or On (1)			On (1)			RW	Bit				US
12.023	Threshold Detector 2 Source	0.000 to 59.999			0.000			RW	Num			PT	US
12.024	Threshold Detector 2 Level	0.00 to 100.00 %			0.00 %			RW	Num				US
12.025	Threshold Detector 2 Hysteresis	0.00 to 25.00 %			0.00 %			RW	Num				US
12.026	Threshold Detector 2 Output Invert	Off (0) or On (1)			Off (0)			RW	Bit				US
12.027	Threshold Detector 2 Destination	0.000 to 59.999			0.000			RW	Num	DE		PT	US
12.028	Variable Selector 2 Source 1	0.000 to 59.999			0.000			RW	Num			PT	US
12.029	Variable Selector 2 Source 2	0.000 to 59.999			0.000			RW	Num			PT	US
12.030	Variable Selector 2 Mode	Input 1 (0), Input 2 (1), Add (2), Subtract (3), Multiply (4), Divide (5), Time Const (6), Ramp (7), Modulus (8), Powers (9), Sectional (10)			Input 1 (0)			RW	Txt				US
12.031	Variable Selector 2 Destination	0.000 to 59.999			0.000			RW	Num	DE		PT	US
12.032	Variable Selector 2 Output	±100.00 %						RO	Num	ND	NC	PT	
12.033	Variable Selector 2 Source 1 Scaling	±4.000			1.000			RW	Num				US
12.034	Variable Selector 2 Source 2 Scaling	±4.000			1.000			RW	Num				US
12.035	Variable Selector 2 Control	0.00 to 100.00			0.00			RW	Num				US
12.036	Variable Selector 2 Enable	Off (0) or On (1)			On (1)			RW	Bit				US
12.040	Brake Control: Brake Release	Off (0) or On (1)						RO	Bit	ND	NC	PT	
12.041	Brake Control: Enable	Off (0) or On (1)			Off (0)			RW	Bit				US
12.042	Brake Control: Upper Current Threshold	0 to 200 %			50 %			RW	Num				US
12.043	Brake Control: Lower Current Threshold	0 to 200 %			10 %			RW	Num				US
12.044	OL: Brake Control: Brake Release Frequency	0.0 to 20.0 Hz			1.0 Hz			RW	Num				US
	Brake Control: Brake Release Speed		0 to 200			10 rpm							
12.045	OL: Brake Control: Brake Apply Frequency	0.0 to 20.0 Hz			2.0 Hz			RW	Num				US
	RFC: Brake Control: Brake Apply Speed		0 to 200			5 rpm							
12.046	Brake Control: Brake Delay	0.0 to 25.0 s			1.0 s			RW	Num				US
12.047	Brake Control: Post-brake Release Delay	0.0 to 25.0 s			1.0 s			RW	Num				US
12.048	Brake Control: Brake Apply Delay		0.0 to 25.0 s			1.0 s		RW	Num				US
12.049	Brake Control: Enable Position Control During Brake Release		Off (0) or On (1)			Off (0)		RW	Bit				US
12.050	Brake Control: Initial Direction	Ref (0), Forward (1), Reverse (2)				Ref (0)		RW	Txt				US
12.051	Brake Control: Brake Apply Through Zero Threshold	0.0 to 25.0 Hz	0 to 250 rpm			0.0 Hz	0 rpm	RW	Num				US
12.052	Brake Control: Mode		Off (0) or On (1)			Off (0)		RW	Bit				US

RW	Read / Write	RO	Read only	Num	Number parameter	Bit	Bit parameter	Txt	Text string	Bin	Binary parameter	FI	Filtered
ND	No default value	NC	Not copied	PT	Protected parameter	RA	Rating dependent	US	User save	PS	Power-down save	DE	Destination

## 10.13 Menu 13: Standard motion controller

Figure 10-33 Menu 13 logic diagram

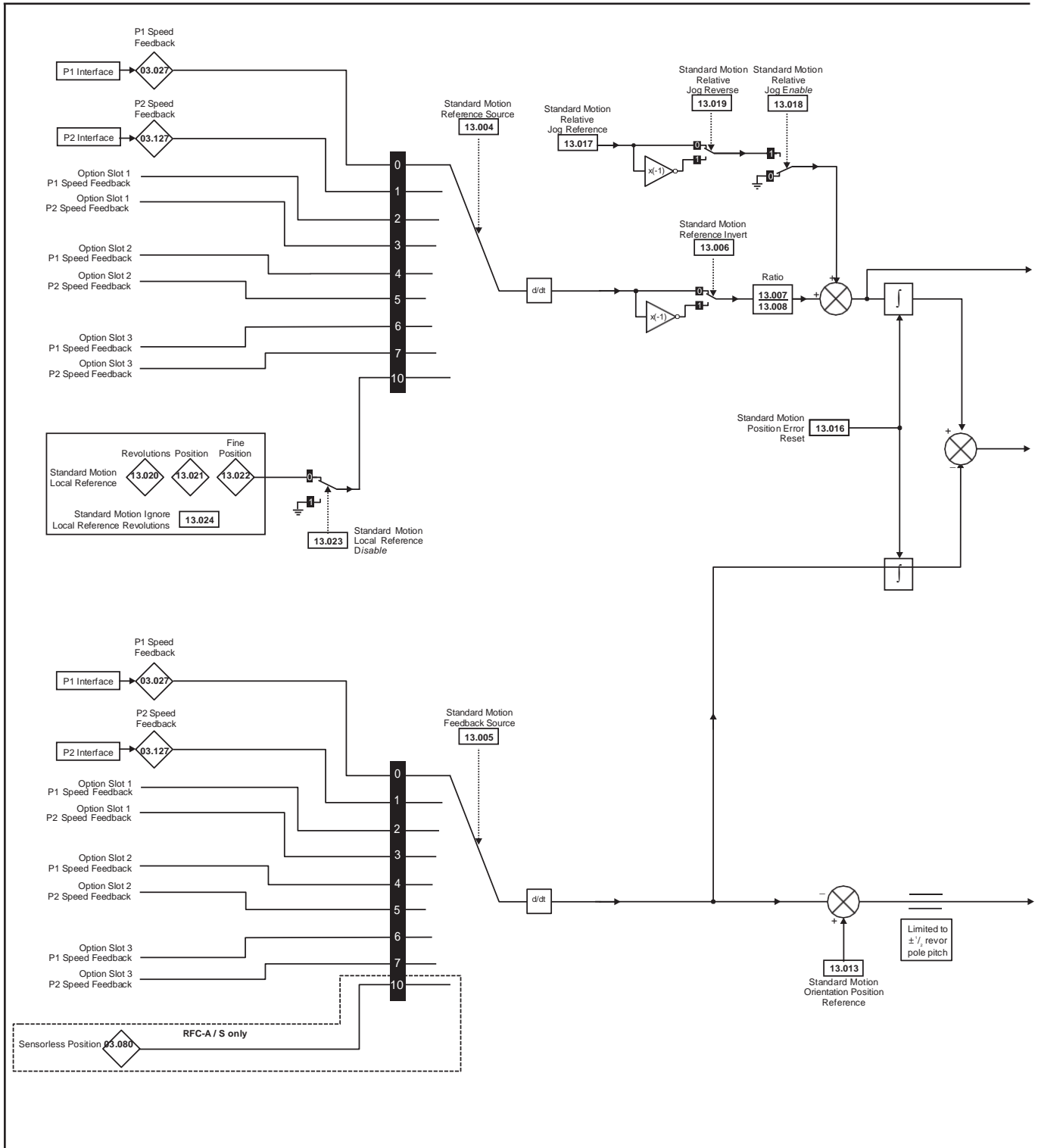

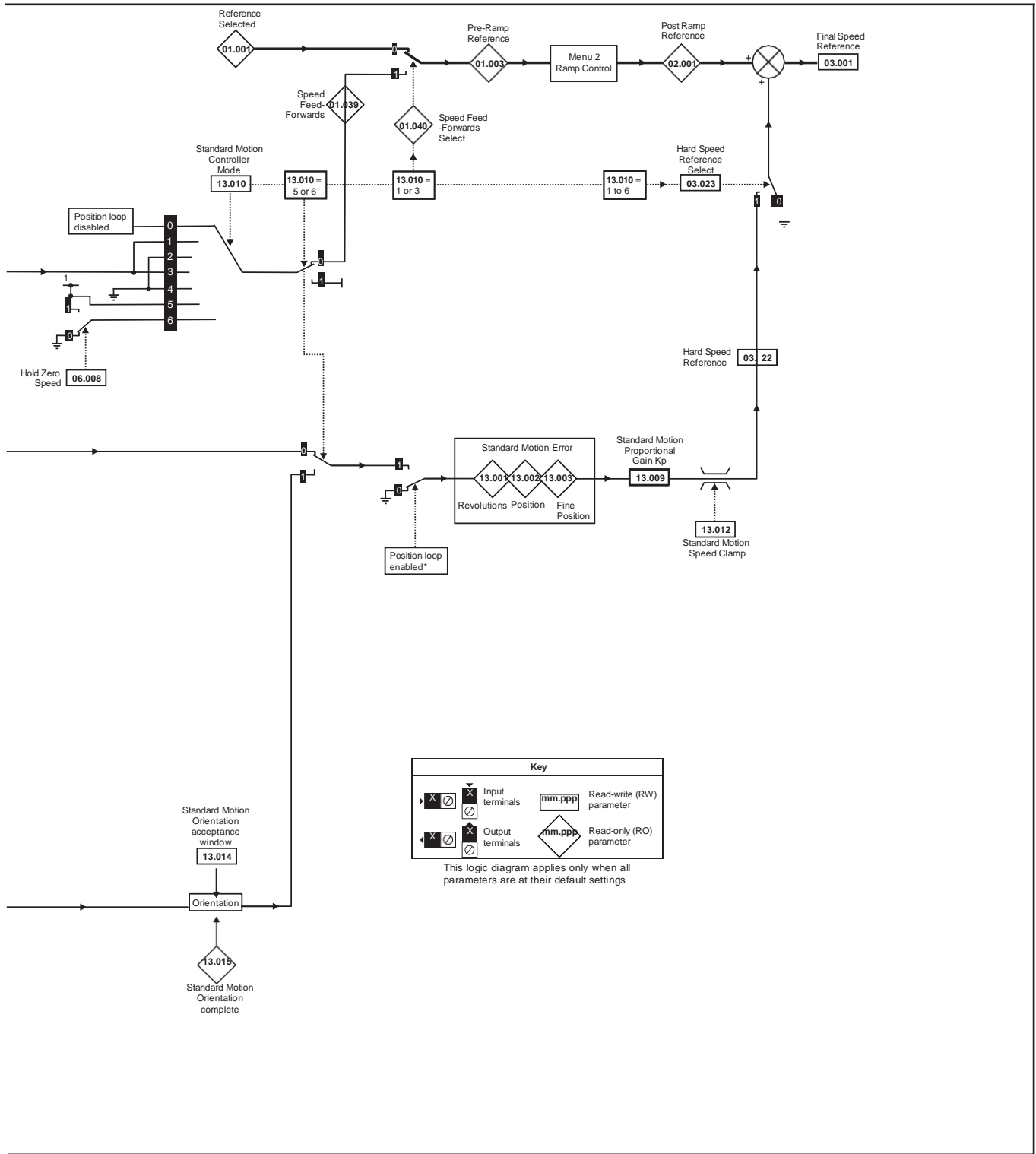

\*The position controller is disabled and the error integrator is also reset under the following conditions:

1. If the drive is disabled (i.e. inhibited, ready or tripped)
2. If the position controller mode (Pr **13.010**) is changed. The position controller is disabled transiently to reset the error integrator.
3. The absolute mode parameter (Pr **13.011**) is changed. The position controller is disabled transiently to reset the error integrator.
4. One of the position sources is invalid.
5. The position feedback initialized parameter (Pr **03.048**) is zero.

Parameter		Range(⇅)		Default(⇔)			Type					
		OL	RFC-A / S	OL	RFC-A	RFC-S						
13.001	Standard Motion Revolutions Error	-32768 to 32767 revs					RO	Num	ND	NC	PT	
13.002	Standard Motion Position Error	-32768 to 32767					RO	Num	ND	NC	PT	
13.003	Standard Motion Fine Position Error	-32768 to 32767					RO	Num	ND	NC	PT	
13.004	Standard Motion Reference Source	P1 Drive (0), P2 Drive (1), P1 Slot 1 (2), P2 Slot 1 (3), P1 Slot 2 (4), P2 Slot 2 (5), P1 Slot 3 (6), P2 Slot 3 (7), Local (10)		P1 Drive (0)			RW	Txt				US
13.005	Standard Motion Feedback Source	P1 Drive (0), P2 Drive (1), P1 Slot 1 (2), P2 Slot 1 (3), P1 Slot 2 (4), P2 Slot 2 (5), P1 Slot 3 (6), P2 Slot 3 (7)	P1 Drive (0), P2 Drive (1), P1 Slot 1 (2), P2 Slot 1 (3), P1 Slot 2 (4), P2 Slot 2 (5), P1 Slot 3 (6), P2 Slot 3 (7), Sensorless (10)	P1 Drive (0)			RW	Txt				US
13.006	Standard Motion Reference Invert	Off (0) or On (1)		Off (0)			RW	Bit				
13.007	Standard Motion Ratio Numerator	0.000 to 10.000		1.000			RW	Num				US
13.008	Standard Motion Ratio Denominator	0.000 to 4.000		1.000			RW	Num				US
13.009	Standard Motion Proportional Gain Kp	0.00 to 100.00		25.00			RW	Num				US
13.010	Standard Motion Controller Mode	Disabled (0), Rigid FFwd (1), Rigid (2), Non-Rigid FFwd (3), Non-Rigid (4)	Disabled (0), Rigid FFwd (1), Rigid (2), Non-Rigid FFwd (3), Non-Rigid (4), Orientate Stop (5), Orientate (6)	Disabled (0)			RW	Num				US
13.011	Standard Motion Absolute Mode Enable	Off (0) or On (1)		Off (0)			RW	Bit				US
13.012	Standard Motion Speed Clamp	0 to 250 rpm		150 rpm			RW	Num				US
13.013	Standard Motion Orientation Position Reference	0 to 65535		0			RW	Num				US
13.014	Standard Motion Orientation Acceptance Window	0 to 4096		256			RW	Num				US
13.015	Standard Motion Orientation Complete	Off (0) or On (1)					RO	Bit	ND	NC	PT	
13.016	Standard Motion Position Error Reset	Off (0) or On (1)		Off (0)			RW	Bit		NC		
13.017	Standard Motion Relative Jog Reference	0.0 to 4000.0 rpm		0.0 rpm			RW	Num				US
13.018	Standard Motion Relative Jog Enable	Off (0) or On (1)		Off (0)			RW	Bit		NC		
13.019	Standard Motion Relative Jog Reverse	Off (0) or On (1)		Off (0)			RW	Bit		NC		
13.020	Standard Motion Local Reference Revolutions	0 to 65535 revs		0 revs			RW	Num		NC		
13.021	Standard Motion Local Reference Position	0 to 65535		0			RW	Num		NC		
13.022	Standard Motion Local Reference Fine Position	0 to 65535		0			RW	Num		NC		
13.023	Standard Motion Local Reference Disable	Off (0) or On (1)		Off (0)			RW	Bit		NC		
13.024	Standard Motion Ignore Local Reference Revolutions	Off (0) or On (1)		Off (0)			RW	Bit				US
13.026	Standard Motion Sample Rate	Not Active (0), 4ms (1)					RO	Txt	ND	NC	PT	US

RW	Read / Write	RO	Read only	Num	Number parameter	Bit	Bit parameter	Txt	Text string	Bin	Binary parameter	FI	Filtered
ND	No default value	NC	Not copied	PT	Protected parameter	RA	Rating dependent	US	User save	PS	Power-down save	DE	Destination



## 10.14 Menu 14: User PID controller

Figure 10-34 Menu 14 Logic diagram

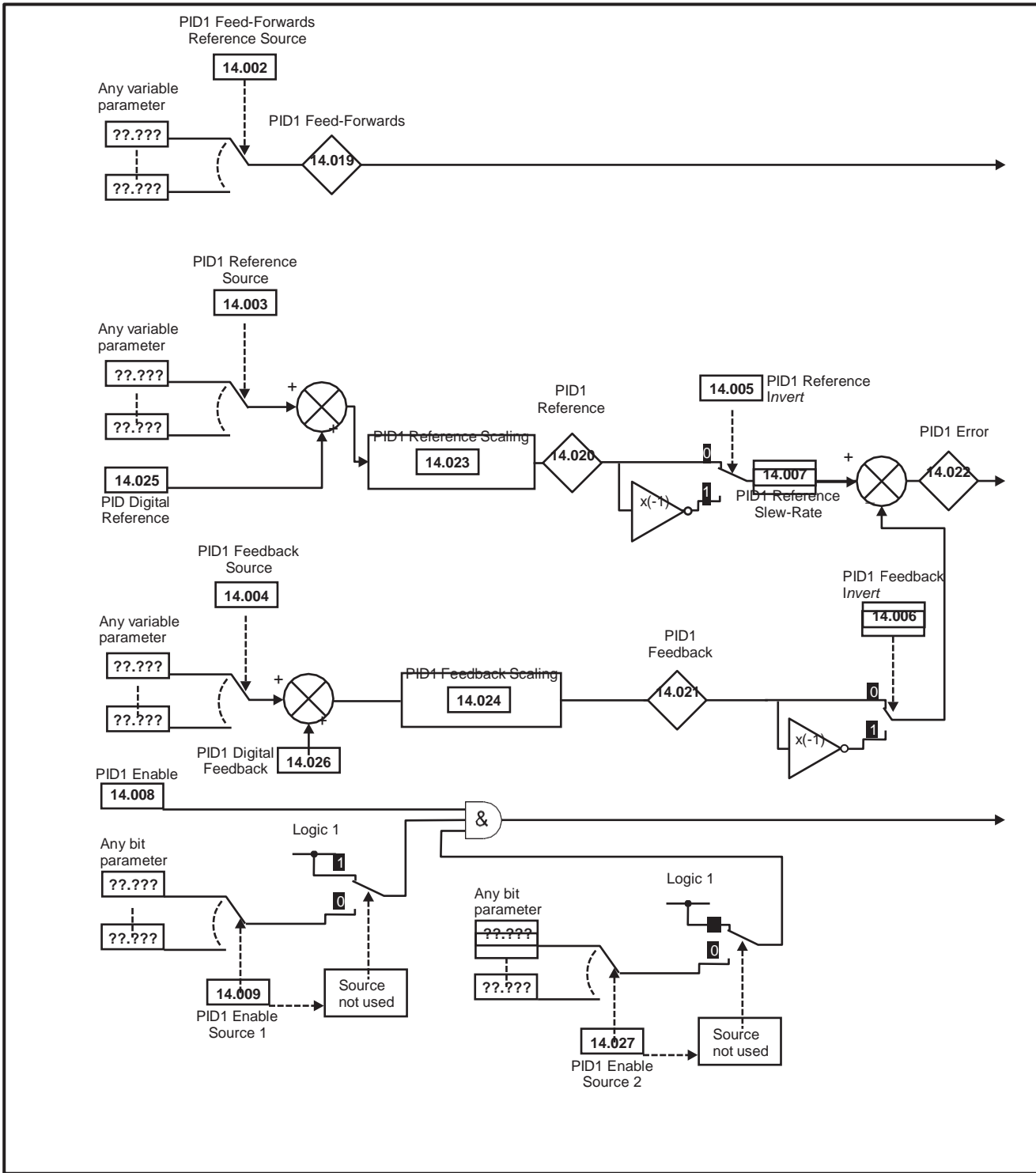

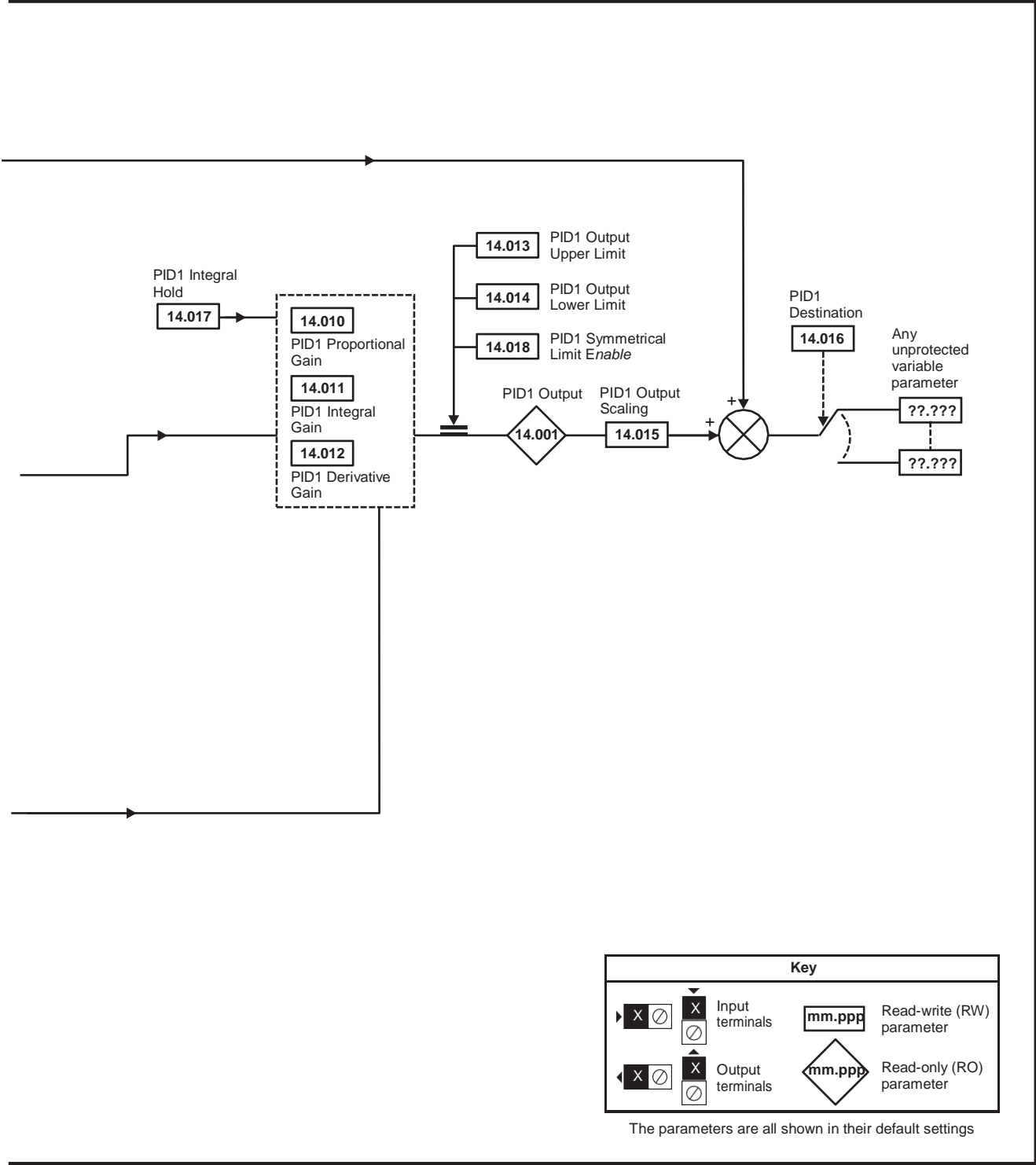

**NOTE**

The same logic diagram above (Menu 14) can also be used for PID2 as they are the same.

Parameter	Range(⇅)		Default(⇔)			Type					
	OL	RFC-A / S	OL	RFC-A	RFC-S						
14.001	PID1 Output	±100.00 %				RO	Num	ND	NC	PT	
14.002	PID1 Feed-forwards Reference Source	0.000 to 59.999		0.000		RW	Num			PT	US
14.003	PID1 Reference Source	0.000 to 59.999		0.000		RW	Num			PT	US
14.004	PID1 Feedback Source	0.000 to 59.999		0.000		RW	Num			PT	US
14.005	PID1 Reference Invert	Off (0) or On (1)		Off (0)		RW	Bit				US
14.006	PID1 Feedback Invert	Off (0) or On (1)		Off (0)		RW	Bit				US
14.007	PID1 Reference Slew Rate	0.0 to 3200.0 s		0.0 s		RW	Num				US
14.008	PID1 Enable	Off (0) or On (1)		Off (0)		RW	Bit				US
14.009	PID1 Enable Source 1	0.000 to 59.999		0.000		RW	Num			PT	US
14.010	PID1 Proportional Gain	0.000 to 4.000		1.000		RW	Num				US
14.011	PID1 Integral Gain	0.000 to 4.000		0.500		RW	Num				US
14.012	PID1 Differential Gain	0.000 to 4.000		0.000		RW	Num				US
14.013	PID1 Output Upper Limit	0.00 to 100.00 %		100.00 %		RW	Num				US
14.014	PID1 Output Lower Limit	±100.00 %		-100.00 %		RW	Num				US
14.015	PID1 Output Scaling	0.000 to 4.000		1.000		RW	Num				US
14.016	PID1 Destination	0.000 to 59.999		0.000		RW	Num	DE		PT	US
14.017	PID1 Integral Hold	Off (0) or On (1)		Off (0)		RW	Bit				
14.018	PID1 Symmetrical Limit Enable	Off (0) or On (1)		Off (0)		RW	Bit				US
14.019	PID1 Feed-forwards Reference	±100.00 %				RO	Num	ND	NC	PT	
14.020	PID1 Reference	±100.00 %				RO	Num	ND	NC	PT	
14.021	PID1 Feedback	±100.00 %				RO	Num	ND	NC	PT	
14.022	PID1 Error	±100.00 %				RO	Num	ND	NC	PT	
14.023	PID1 Reference Scaling	0.000 to 4.000		1.000		RW	Num				US
14.024	PID1 Feedback Scaling	0.000 to 4.000		1.000		RW	Num				US
14.025	PID1 Digital Reference	±100.00 %		0.00 %		RW	Num				US
14.026	PID1 Digital Feedback	±100.00 %		0.00 %		RW	Num				US
14.027	PID1 Enable Source 2	0.000 to 59.999		0.000		RW	Num			PT	US
14.028	PID1 Pre-sleep Boost Level	0.00 to 100.00 %		0.00 %		RW	Num				US
14.029	PID1 Maximum Boost Time	0.0 to 250.0 s		0.0 s		RW	Num				US
14.030	PID1 Pre-sleep Boost Level Enable	Off (0) or On (1)				RO	Bit	ND	NC	PT	
14.031	PID2 Output	±100.00 %				RO	Num	ND	NC	PT	
14.032	PID2 Feed-forwards Reference Source	0.000 to 59.999		0.000		RW	Num			PT	US
14.033	PID2 Reference Source	0.000 to 59.999		0.000		RW	Num			PT	US
14.034	PID2 Feedback Source	0.000 to 59.999		0.000		RW	Num			PT	US
14.035	PID2 Reference Invert	Off (0) or On (1)		Off (0)		RW	Bit				US
14.036	PID2 Feedback Invert	Off (0) or On (1)		Off (0)		RW	Bit				US
14.037	PID2 Reference Slew Rate Limit	0.0 to 3200.0 s		0.0 s		RW	Num				US
14.038	PID2 Enable	Off (0) or On (1)		Off (0)		RW	Bit				US
14.039	PID2 Enable Source 1	0.000 to 59.999		0.000		RW	Num			PT	US
14.040	PID2 Proportional Gain	0.000 to 4.000		1.000		RW	Num				US
14.041	PID2 Integral Gain	0.000 to 4.000		0.500		RW	Num				US
14.042	PID2 Differential Gain	0.000 to 4.000		0.000		RW	Num				US
14.043	PID2 Output Upper Limit	0.00 to 100.00 %		100.00 %		RW	Num				US
14.044	PID2 Output Lower Limit	±100.00 %		-100.00 %		RW	Num				US
14.045	PID2 Output Scaling	0.000 to 4.000		1.000		RW	Num				US
14.046	PID2 Destination	0.000 to 59.999		0.000		RW	Num	DE		PT	US
14.047	PID2 Integral Hold	Off (0) or On (1)		Off (0)		RW	Bit				
14.048	PID2 Symmetrical Limit Enable	Off (0) or On (1)		Off (0)		RW	Bit				US
14.049	PID2 Feed-forwards Reference	±100.00 %				RO	Num	ND	NC	PT	
14.050	PID2 Reference	±100.00 %				RO	Num	ND	NC	PT	
14.051	PID2 Feedback	±100.00 %				RO	Num	ND	NC	PT	
14.052	PID2 Error	±100.00 %				RO	Num	ND	NC	PT	
14.053	PID2 Reference Scaling	0.000 to 4.000		1.000		RW	Num				US
14.054	PID2 Feedback Scaling	0.000 to 4.000		1.000		RW	Num				US
14.055	PID2 Digital Reference	±100.00 %		0.00 %		RW	Num				US
14.056	PID2 Digital Feedback	±100.00 %		0.00 %		RW	Num				US
14.057	PID2 Enable Source 2	0.000 to 59.999		0.000		RW	Num			PT	US

Safety information	Product information	Electrical installation	Getting started	Basic parameters	Running the motor	Optimization	NV Media Card Operation	Onboard PLC	<b>Advanced parameters</b>	Technical data	Diagnostics	UL listing information
--------------------	---------------------	-------------------------	-----------------	------------------	-------------------	--------------	-------------------------	-------------	----------------------------	----------------	-------------	------------------------

Parameter		Range(⇅)		Default(⇄)			Type					
		OL	RFC-A / S	OL	RFC-A	RFC-S						
14.058	PID1 Feedback Output Scaling	0.000 to 4.000		1.000			RW	Num				US
14.059	PID1 Mode Selector	Fbk1 (0), Fbk2 (1), Fbk1 + Fbk2 (2), Min Fbk (3), Max Fbk (4), Av Fbk (5), Min Error (6), Max Error (7)		Fbk1 (0)			RW	Txt				US
14.060	PID1 Feedback Square Root Enable 1	Off (0) or On (1)		Off (0)			RW	Bit				US
14.061	PID2 Feedback Square Root Enable	Off (0) or On (1)		Off (0)			RW	Bit				US
14.062	PID1 Feedback Square Root Enable 2	Off (0) or On (1)		Off (0)			RW	Bit				US

RW	Read / Write	RO	Read only	Num	Number parameter	Bit	Bit parameter	Txt	Text string	Bin	Binary parameter	FI	Filtered
ND	No default value	NC	Not copied	PT	Protected parameter	RA	Rating dependent	US	User save	PS	Power-down save	DE	Destination

## 10.15 Menus 15, 16 and 17: Option module set-up

Figure 10-35 Location of option module slots and their corresponding menu numbers

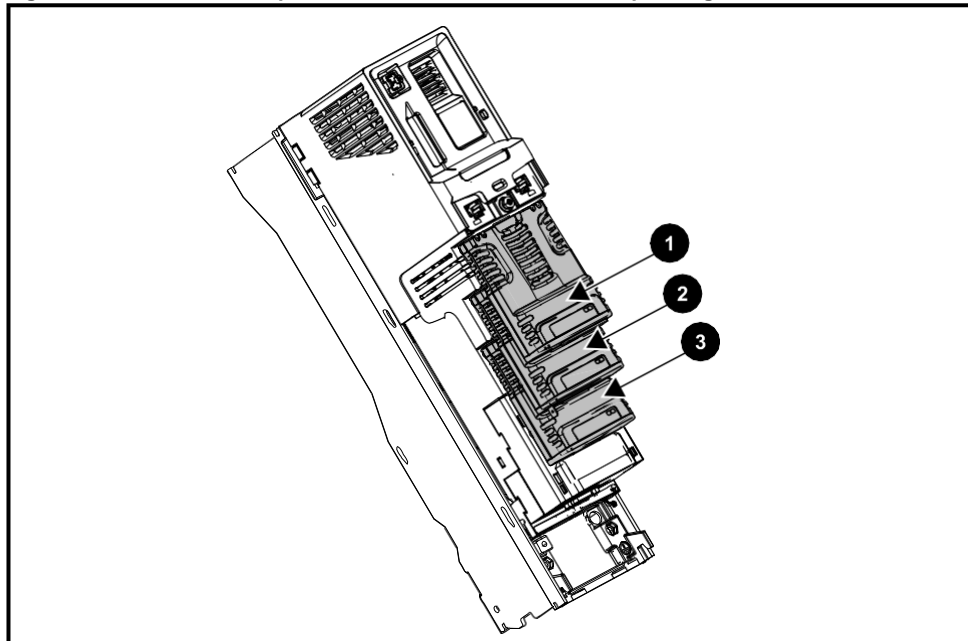

1. Solutions Module Slot 1 - Menu 15
2. Solutions Module Slot 2 - Menu 16
3. Solutions Module Slot 3 - Menu 17

### 10.15.1 Parameters common to all categories

Parameter		Range(⇅)	Default(⇔)	Type					
mm.001	Module ID	0 to 65535		RO	Num	ND	NC	PT	
mm.002	Software Version	00.00.00 to 99.99.99		RO	Num	ND	NC	PT	
mm.003	Hardware Version	0.00 to 99.99		RO	Num	ND	NC	PT	
mm.004	Serial Number LS	0 to 99999999		RO	Num	ND	NC	PT	
mm.005	Serial Number MS			RO	Num	ND	NC	PT	

The option module ID indicates the type of module that is installed in the corresponding slot. See the relevant option module user guide for more information regarding the module.

Option module ID	Module	Category
0	No module installed	
209	SI-I/O	Automation (I/O Expansion)
304	SI-Applications Plus	Automation (Applications)
310	MCi210	
311	MCi200	
306	SI-Register	
443	SI-PROFIBUS	
447	SI-DeviceNet	Fieldbus

## 10.16 Menu 18: Application menu 1

Parameter	Range(⇅)		Default(⇔)			Type					
	OL	RFC-A / S	OL	RFC-A	RFC-S						
18.001 Application Menu 1 Power-down Save Integer	-32768 to 32767		0			RW	Num				PS
18.002 to 18.010 Application Menu 1 Read-only Integer	-32768 to 32767					RO	Num	ND	NC		US
18.011 to 18.030 Application Menu 1 Read-write Integer	-32768 to 32767		0			RW	Num				US
18.031 to 18.050 Application Menu 1 Read-write bit	Off (0) or On (1)		Off (0)			RW	Bit				US
18.051 to 18.054 Application Menu 1 Power-down Save long Integer	-2147483648 to 2147483647		0			RW	Num				PS

## 10.17 Menu 19: Application menu 2

Parameter	Range(⇅)		Default(⇔)			Type					
	OL	RFC-A / S	OL	RFC-A	RFC-S						
19.001 Application Menu 2 Power-down Save Integer	-32768 to 32767		0			RW	Num				PS
19.002 to 19.010 Application Menu 2 Read-only Integer	-32768 to 32767					RO	Num	ND	NC		US
19.011 to 19.030 Application Menu 2 Read-write Integer	-32768 to 32767		0			RW	Num				US
19.031 to 19.050 Application Menu 2 Read-write bit	Off (0) or On (1)		Off (0)			RW	Bit				US
19.051 to 19.054 Application Menu 2 Power-down Save long Integer	-2147483648 to 2147483647		0			RW	Num				PS

## 10.18 Menu 20: Application menu 3

Parameter	Range(⇅)		Default(⇔)			Type					
	OL	RFC-A / S	OL	RFC-A	RFC-S						
20.001 to 20.020 Application Menu 3 Read-write Integer	-32768 to 32767		0			RW	Num				
20.021 to 20.040 Application Menu 3 Read-write Long Integer	-32768 to 32767					RW	Num				

RW	Read / Write	RO	Read only	Num	Number parameter	Bit	Bit parameter	Txt	Text string	Bin	Binary parameter	FI	Filtered
ND	No default value	NC	Not copied	PT	Protected parameter	RA	Rating dependent	US	User save	PS	Power-down save	DE	Destination

## 10.19 Menu 21: Second motor parameters

Parameter		Range(↕)			Default(⇔)			Type					
		OL	RFC-A	RFC-S	OL	RFC-A	RFC-S						
21.001	M2 Maximum Reference Clamp	±VM_POSITIVE_REF_CLAMP2 Hz	±VM_POSITIVE_REF_CLAMP2 rpm		50 Hz: 50.0 60 Hz: 60.0	50 Hz: 1500.0 60 Hz: 1800.0	3000.0	RW	Num				US
21.002	M2 Minimum Reference Clamp	±VM_NEGATIVE_REF_CLAMP2 Hz	±VM_NEGATIVE_REF_CLAMP2 rpm		0.0			RW	Num				US
21.003	M2 Reference Selector	A1 A2 (0), A1 Preset (1), A2 Preset (2), Preset (3), Keypad (4), Precision (5), Keypad Ref (6)			A1 A2 (0)			RW	Txt				US
21.004	M2 Acceleration Rate 1	±VM_ACCEL_RATE			5.0	2.000	0.200	RW	Num				US
21.005	M2 Deceleration Rate 1	±VM_ACCEL_RATE			10.0	2.000	0.200	RW	Num				US
21.006	M2 Rated Frequency	0.0 to 3000.0 Hz	0.0 to 1667.0 Hz		50 Hz: 50.0 60 Hz: 60.0			RW	Num				US
21.007	M2 Rated Current	±VM_RATED_CURRENT A			0.000 A			RW	Num	RA			US
21.008	M2 Rated Speed	0 to 180000 rpm	0.00 to 50000.00 rpm		50 Hz: 1500 rpm 60 Hz: 1800 rpm	50 Hz: 1450.00 rpm 60 Hz: 1750.00 rpm	3000.00 rpm	RW	Num				US
21.009	M2 Rated Voltage	±VM_AC_VOLTAGE_SET V			200V drive: 230 V 400V drive 50Hz: 400 V 400V drive 60Hz: 460 V 575V drive: 575 V 690V drive: 690 V			RW	Num	RA			US
21.010	M2 Rated Power Factor	0.000 to 1.000			0.850			RW	Num	RA			US
21.011	M2 Number Of Motor Poles	Automatic (0) to 480 Poles (240)			Automatic (0)		6 Poles (3)	RW	Txt				US
21.012	M2 Stator Resistance	0.000000 to 1000.000000 Ω			0.000000 Ω			RW	Num	RA			US
21.014	M2 Transient Inductance / Ld	0.000 to 500.000 mH			0.000 mH			RW	Num	RA			US
21.015	Motor 2 Active	Off (0) or On (1)						RO	Bit	ND	NC	PT	
21.016	M2 Motor Thermal Time Constant 1	1.0 to 3000.0 s			89.0 s			RW	Num				US
21.017	M2 Speed Controller Proportional Gain Kp1	0.0000 to 200.0000			0.0300			RW	Num				US
21.018	M2 Speed Controller Integral Gain Ki1	0.00 to 655.35			0.10		1.00	RW	Num				US
21.019	M2 Speed Controller Differential Feedback Gain Kd1	0.00000 to 0.65535			0.00000			RW	Num				US
21.020	M2 Position Feedback Phase Angle	0.0 to 359.9 °						RW	Num	ND			US
21.021	M2 Motor Control Feedback Select	P1 Drive (0), P2 Drive (1), P1 Slot 1 (2), P2 Slot 1 (3), P1 Slot 2 (4), P2 Slot 2 (5), P1 Slot 3 (6), P2 Slot 3 (7), P1 Slot 4 (8), P2 Slot 4 (9)			P1 Drive (0)			RW	Txt				US
21.022	M2 Current Controller Kp Gain	0 to 30000			20	150		RW	Num				US
21.023	M2 Current Controller Ki Gain	0 to 30000			40	2000		RW	Num				US
21.024	M2 Stator Inductance	0.00 to 5000.00 mH			0.00 mH			RW	Num	RA			US
21.025	M2 Saturation Breakpoint 1	0.0 to 100.0 %			50.0 %			RW	Num				US
21.026	M2 Saturation Breakpoint 3	0.0 to 100.0 %			75.0 %			RW	Num				US
21.027	M2 Motoring Current Limit	±VM_MOTOR2_CURRENT_LIMIT %			165.0 %	175.0 %		RW	Num	RA			US
21.028	M2 Regenerating Current Limit	±VM_MOTOR2_CURRENT_LIMIT %			165.0 %	175.0 %		RW	Num	RA			US
21.029	M2 Symmetrical Current Limit	±VM_MOTOR2_CURRENT_LIMIT %			165.0 %	175.0 %		RW	Num	RA			US
21.030	M2 Volts Per 1000 rpm			0 to 10,000 V			98	RW	Num				US
21.032	M2 Current Reference Filter Time Constant 1	0.0 to 25.0 ms			0.0 ms			RW	Num				US
21.033	M2 Low Speed Thermal Protection Mode	0 to 1			0			RW	Num				US
21.034	M2 Current Controller Mode	Off (0) or On (1)			Off (0)			RW	Bit				US
21.035	M2 Notch Filter Centre Frequency	50 to 1000 Hz			100 Hz			RW	Num				US
21.036	M2 Notch Filter Bandwidth	0 to 500 Hz			0 Hz			RW	Num				US
21.039	M2 Motor Thermal Time Constant 2	1.0 to 3000.0 s			89.0 s			RW	Num				US
21.040	M2 Motor Thermal Time Constant 2 Scaling	0 to 100 %			0 %			RW	Num				US
21.041	M2 Saturation Breakpoint 2	0.0 to 100.0 %			0.0 %			RW	Num				US
21.042	M2 Saturation Breakpoint 4	0.0 to 100.0 %			0.0 %			RW	Num				US
21.043	RFC-A> M2 Torque Per Amp	0.00 to 500.00 Nm/A						RO	Num	ND	NC	PT	
	RFC-S> M2 Torque Per Amp	0.00 to 500.00 Nm/A					1.60 Nm/A	RW	Num				US
21.046	M2 Inverted Motor Saturation Characteristic				Off (0) or On (1)		Off (0)	RW	Bit				US
21.047	M2 Low Speed Sensorless Mode Current Limit				0.0 to 1000.0 %		20.0 %	RW	Num	RA			US

Parameter		Range(⇅)			Default(⇄)			Type				
		OL	RFC-A	RFC-S	OL	RFC-A	RFC-S					
21.048	M2 No-load Lq			0.000 to 500.000 mH			0.0 mH	RW	Num		RA	US
21.051	M2 Iq Test Current For Inductance Measurement			0 to 200 %			100 %	RW	Num			US
21.053	M2 Phase Offset At Iq Test Current			± 90.0 °			0.0 °	RW	Num		RA	US
21.054	M2 Lq At Defined Iq Test Current			0.00 to 500.00 mH			0.000 mH	RW	Num		RA	US
21.058	M2 Id Test Current For Inductance Measurement			-100 to 0 %			-50 %	RW	Num			US
21.060	M2 Lq at the defined Id test current			0.000 to 500.000 mH			0.000 mH	RW	Num		RA	US
21.066	M2 Torque Ripple Compensation Magnitude 1			0.0 to 100.0 %			0.00 %	RW	Num			US
21.067	M2 Torque Ripple Compensation Phase 1			0.0 to 359 °			0.0 °	RW	Num			US
21.068	M2 Torque Ripple Compensation Magnitude 2			0.0 to 100.0 %			0.00 %	RW	Num			US
21.069	M2 Torque Ripple Compensation Phase 2			0.0 to 359 °			0.0 °	RW	Num			US
21.070	M2 Torque Ripple Compensation Magnitude 3			0.0 to 100.0 %			0.00 %	RW	Num			US
21.071	M2 Torque Ripple Compensation Phase 3			0.0 to 359 °			0.0 °	RW	Num			US
21.072	M2 Torque Ripple Compensation Magnitude 4			0.0 to 100.0 %			0.00 %	RW	Num			US
21.073	M2 Torque Ripple Compensation Phase 4			0.0 to 359 °			0.0 °	RW	Num			US
21.074	M2 Torque Ripple Compensation Magnitude 5			0.0 to 100.0 %			0.00 %	RW	Num			US
21.075	M2 Torque Ripple Compensation Phase 5			0.0 to 359 °			0.0 °	RW	Num			US
21.076	M2 Torque Ripple Compensation Magnitude 6			0.0 to 100.0 %			0.00 %	RW	Num			US
21.077	M2 Torque Ripple Compensation Phase 6			0.0 to 359 °			0.0 °	RW	Num			US
21.078	M2 Torque Ripple Compensation Magnitude 7			0.0 to 100.0 %			0.00 %	RW	Num			US
21.079	M2 Torque Ripple Compensation Phase 7			0.0 to 359 °			0.0 °	RW	Num			US
21.080	M2 Torque Ripple Compensation Magnitude 8			0.0 to 100.0 %			0.00 %	RW	Num			US
21.081	M2 Torque Ripple Compensation Phase 8			0.0 to 359 °			0.0 °	RW	Num			US
21.082	M2 Torque Ripple Compensation Magnitude 9			0.0 to 100.0 %			0.00 %	RW	Num			US
21.083	M2 Torque Ripple Compensation Phase 9			0.0 to 359 °			0.0 °	RW	Num			US
21.084	M2 Torque Ripple Compensation Magnitude 10			0.0 to 100.0 %			0.00 %	RW	Num			US
21.085	M2 Torque Ripple Compensation Phase 10			0.0 to 359 °			0.0 °	RW	Num			US

RW	Read / Write	RO	Read only	Num	Number parameter	Bit	Bit parameter	Txt	Text string	Bin	Binary parameter	Fl	Filtered
ND	No default value	NC	Not copied	PT	Protected parameter	RA	Rating dependent	US	User save	PS	Power-down save	DE	Destination

## 10.20 Menu 22: Additional Menu 0 set-up

Parameter	Range(⇅)	Default(⇄)			Type								
		OL	RFC-A	RFC-S			OL	RFC-A	RFC-S				
22.001	Parameter 00.001 Set-up	0.000 to 59.999			1.007			RW	Num			PT	US
22.002	Parameter 00.002 Set-up	0.000 to 59.999			1.006			RW	Num			PT	US
22.003	Parameter 00.003 Set-up	0.000 to 59.999			2.011			RW	Num			PT	US
22.004	Parameter 00.004 Set-up	0.000 to 59.999			2.021			RW	Num			PT	US
22.005	Parameter 00.005 Set-up	0.000 to 59.999			1.014			RW	Num			PT	US
22.006	Parameter 00.006 Set-up	0.000 to 59.999			4.007			RW	Num			PT	US
22.007	Parameter 00.007 Set-up	0.000 to 59.999			5.014	3.010		RW	Num			PT	US
22.008	Parameter 00.008 Set-up	0.000 to 59.999			5.015	3.011		RW	Num			PT	US
22.009	Parameter 00.009 Set-up	0.000 to 59.999			5.013	3.012		RW	Num			PT	US
22.010	Parameter 00.010 Set-up	0.000 to 59.999			5.004	3.002		RW	Num			PT	US
22.011	Parameter 00.011 Set-up	0.000 to 59.999			5.001		3.029	RW	Num			PT	US
22.012	Parameter 00.012 Set-up	0.000 to 59.999			4.001			RW	Num			PT	US
22.013	Parameter 00.013 Set-up	0.000 to 59.999			4.002			RW	Num			PT	US
22.014	Parameter 00.014 Set-up	0.000 to 59.999			4.011			RW	Num			PT	US
22.015	Parameter 00.015 Set-up	0.000 to 59.999			2.004			RW	Num			PT	US
22.016	Parameter 00.016 Set-up	0.000 to 59.999			0.000	2.002		RW	Num			PT	US
22.017	Parameter 00.017 Set-up	0.000 to 59.999			8.026	4.012		RW	Num			PT	US
22.018	Parameter 00.018 Set-up	0.000 to 59.999			0.000			RW	Num			PT	US
22.019	Parameter 00.019 Set-up	0.000 to 59.999			7.011*			RW	Num			PT	US
22.020	Parameter 00.020 Set-up	0.000 to 59.999			7.014*			RW	Num			PT	US
22.021	Parameter 00.021 Set-up	0.000 to 59.999			7.015*			RW	Num			PT	US
22.022	Parameter 00.022 Set-up	0.000 to 59.999			1.010			RW	Num			PT	US
22.023	Parameter 00.023 Set-up	0.000 to 59.999			1.005			RW	Num			PT	US
22.024	Parameter 00.024 Set-up	0.000 to 59.999			1.021			RW	Num			PT	US
22.025	Parameter 00.025 Set-up	0.000 to 59.999			1.022			RW	Num			PT	US
22.026	Parameter 00.026 Set-up	0.000 to 59.999			1.023	3.008		RW	Num			PT	US
22.027	Parameter 00.027 Set-up	0.000 to 59.999			1.024	3.034		RW	Num			PT	US
22.028	Parameter 00.028 Set-up	0.000 to 59.999			6.013			RW	Num			PT	US
22.029	Parameter 00.029 Set-up	0.000 to 59.999			11.036			RW	Num			PT	US
22.030	Parameter 00.030 Set-up	0.000 to 59.999			11.042			RW	Num			PT	US
22.031	Parameter 00.031 Set-up	0.000 to 59.999			11.033			RW	Num			PT	US
22.032	Parameter 00.032 Set-up	0.000 to 59.999			11.032			RW	Num			PT	US
22.033	Parameter 00.033 Set-up	0.000 to 59.999			6.009	5.016	0.000	RW	Num			PT	US
22.034	Parameter 00.034 Set-up	0.000 to 59.999			11.030			RW	Num			PT	US
22.035	Parameter 00.035 Set-up	0.000 to 59.999			11.024*			RW	Num			PT	US
22.036	Parameter 00.036 Set-up	0.000 to 59.999			11.025*			RW	Num			PT	US
22.037	Parameter 00.037 Set-up	0.000 to 59.999			11.023** / 24.010***			RW	Num			PT	US
22.038	Parameter 00.038 Set-up	0.000 to 59.999			4.013			RW	Num			PT	US
22.039	Parameter 00.039 Set-up	0.000 to 59.999			4.014			RW	Num			PT	US
22.040	Parameter 00.040 Set-up	0.000 to 59.999			5.012			RW	Num			PT	US
22.041	Parameter 00.041 Set-up	0.000 to 59.999			5.018			RW	Num			PT	US
22.042	Parameter 00.042 Set-up	0.000 to 59.999			5.011			RW	Num			PT	US
22.043	Parameter 00.043 Set-up	0.000 to 59.999			5.010	3.025		RW	Num			PT	US
22.044	Parameter 00.044 Set-up	0.000 to 59.999			5.009			RW	Num			PT	US
22.045	Parameter 00.045 Set-up	0.000 to 59.999			5.008	4.015		RW	Num			PT	US
22.046	Parameter 00.046 Set-up	0.000 to 59.999			5.007			RW	Num			PT	US
22.047	Parameter 00.047 Set-up	0.000 to 59.999			5.006	0.000		RW	Num			PT	US
22.048	Parameter 00.048 Set-up	0.000 to 59.999			11.031			RW	Num			PT	US
22.049	Parameter 00.049 Set-up	0.000 to 59.999			11.044			RW	Num			PT	US
22.050	Parameter 00.050 Set-up	0.000 to 59.999			11.029			RW	Num			PT	US
22.051	Parameter 00.051 Set-up	0.000 to 59.999			10.037			RW	Num			PT	US
22.052	Parameter 00.052 Set-up	0.000 to 59.999			11.020 *			RW	Num			PT	US
22.053	Parameter 00.053 Set-up	0.000 to 59.999			0.000			RW	Num			PT	US
22.054	Parameter 00.054 Set-up	0.000 to 59.999			0.000			RW	Num			PT	US
22.055	Parameter 00.055 Set-up	0.000 to 59.999			0.000			RW	Num			PT	US
22.056	Parameter 00.056 Set-up	0.000 to 59.999			0.000			RW	Num			PT	US
22.057	Parameter 00.057 Set-up	0.000 to 59.999			0.000			RW	Num			PT	US

Safety information	Product information	Electrical installation	Getting started	Basic parameters	Running the motor	Optimization	NV Media Card Operation	Onboard PLC	Advanced parameters	Technical data	Diagnostics	UL listing information
--------------------	---------------------	-------------------------	-----------------	------------------	-------------------	--------------	-------------------------	-------------	---------------------	----------------	-------------	------------------------

Parameter	Parameter	Range(⇅)			Default(⇄)			Type					
		OL	RFC-A	RFC-S	OL	RFC-A	RFC-S						
22.058	Parameter 00.058 Set-up	0.000 to 59.999			0.000			RW	Num			PT	US
22.059	Parameter 00.059 Set-up	0.000 to 59.999			0.000			RW	Num			PT	US
22.060	Parameter 00.060 Set-up	0.000 to 59.999			0.000			RW	Num			PT	US
22.061	Parameter 00.061 Set-up	0.000 to 59.999			0.000			RW	Num			PT	US
22.062	Parameter 00.062 Set-up	0.000 to 59.999			0.000			RW	Num			PT	US
22.063	Parameter 00.063 Set-up	0.000 to 59.999			0.000			RW	Num			PT	US
22.064	Parameter 00.064 Set-up	0.000 to 59.999			0.000			RW	Num			PT	US
22.065	Parameter 00.065 Set-up	0.000 to 59.999			0.000			RW	Num			PT	US
22.066	Parameter 00.066 Set-up	0.000 to 59.999			0.000			RW	Num			PT	US
22.067	Parameter 00.067 Set-up	0.000 to 59.999			0.000			RW	Num			PT	US
22.068	Parameter 00.068 Set-up	0.000 to 59.999			0.000			RW	Num			PT	US
22.069	Parameter 00.069 Set-up	0.000 to 59.999			0.000			RW	Num			PT	US
22.070	Parameter 00.070 Set-up	0.000 to 59.999			0.000			RW	Num			PT	US
22.071	Parameter 00.071 Set-up	0.000 to 59.999			0.000			RW	Num			PT	US
22.072	Parameter 00.072 Set-up	0.000 to 59.999			0.000			RW	Num			PT	US
22.073	Parameter 00.073 Set-up	0.000 to 59.999			0.000			RW	Num			PT	US
22.074	Parameter 00.074 Set-up	0.000 to 59.999			0.000			RW	Num			PT	US
22.075	Parameter 00.075 Set-up	0.000 to 59.999			0.000			RW	Num			PT	US
22.076	Parameter 00.076 Set-up	0.000 to 59.999			0.000			RW	Num			PT	US
22.077	Parameter 00.077 Set-up	0.000 to 59.999			0.000			RW	Num			PT	US
22.078	Parameter 00.078 Set-up	0.000 to 59.999			0.000			RW	Num			PT	US
22.079	Parameter 00.079 Set-up	0.000 to 59.999			0.000			RW	Num			PT	US
22.080	Parameter 00.080 Set-up	0.000 to 59.999			0.000			RW	Num			PT	US

\* 0.000 on Unidrive HS72.

\*\* On Unidrive HS71.

\*\*\* On Unidrive HS70 / HS72.

RW	Read / Write	RO	Read only	Num	Number parameter	Bit	Bit parameter	Txt	Text string	Bin	Binary parameter	FI	Filtered
ND	No default value	NC	Not copied	PT	Protected parameter	RA	Rating dependent	US	User save	PS	Power-down save	DE	Destination

## 10.21 Menu 24: Ethernet status and monitoring (Unidrive HS70 / HS72)

Parameter	Parameter	Range			Default			Type					
		OL	RFC-A	RFC-S	OL	RFC-A	RFC-S						
24.001	Module ID	0 to 65535						RO	Num	ND	NC	PT	
24.002	Software Version	00.00.00.00 to 99.99.99.99						RO	Num	ND	NC	PT	
24.003	Hardware Version	0.00 to 99.99						RO	Num	ND	NC	PT	
24.004	Serial Number LS	00000000 to 99999999						RO	Num	ND	NC	PT	
24.005	Serial Number MS	0 to 99999999						RO	Num	ND	NC	PT	
24.006	Status	Bootldr-Update (-2), Bootldr-Idle (-1), Initializing (0), OK (1), Config (2), Error (3)						RO	Txt	ND	NC	PT	
24.007	Reset	Off (0) or On (1)			Off (0)			RW	Bit		NC		
24.008	Default	Off (0) or On (1)			Off (0)			RW	Bit		NC		
24.009	Active Alarm Bits	0000000000000000 to 1111111111111111			0000000000000000			RO	Bin		NC		
24.010	Active IP Address	128.0.0.0 to 127.255.255.255			0.0.0.0			RO	IP		NC	PT	

RW	Read / Write	RO	Read only	Num	Number parameter	Bit	Bit parameter	Txt	Text string	Bin	Binary parameter	FI	Filtered
ND	No default value	NC	Not copied	PT	Protected parameter	RA	Rating dependent	US	User save	PS	Power-down save	DE	Destination
IP	IP address	Mac	Mac address	Date	Date parameter	Time	Time parameter	SMP	Slot,menu,parameter	Chr	Character parameter	Ver	Version number

### 10.21.1 Slot 4 Menu 0: Ethernet status and monitoring (Unidrive HS70 / HS72)

Parameter	Range			Default			Type						
	OL	RFC-A	RFC-S	OL	RFC-A	RFC-S							
24.001	Module ID	0 to 65535						RO	Num	ND	NC	PT	
24.002	Software Version	00.00.00.00 to 99.99.99.99						RO	Num	ND	NC	PT	
24.003	Hardware Version	0.00 to 99.99						RO	Num	ND	NC	PT	
24.004	Serial Number LS	00000000 to 99999999						RO	Num	ND	NC	PT	
24.005	Serial Number MS	0 to 99999999						RO	Num	ND	NC	PT	
24.006	Status	Bootldr-Update (-2), Bootldr-Idle (-1), Initializing (0), OK (1), Config (2), Error (3)						RO	Txt	ND	NC	PT	
24.007	Reset	Off (0) or On (1)			Off (0)			RW	Bit		NC		
24.008	Default	Off (0) or On (1)			Off (0)			RW	Bit		NC		
24.009	Active Alarm Bits	0000000000000000 to 1111111111111111			0000000000000000			RO	Bin		NC		
24.010	Active IP Address	128.0.0.0 to 127.255.255.255			0.0.0.0			RO	IP		NC	PT	

RW	Read / Write	RO	Read only	Num	Number parameter	Bit	Bit parameter	Txt	Text string	Bin	Binary parameter	FI	Filtered
ND	No default value	NC	Not copied	PT	Protected parameter	RA	Rating dependent	US	User save	PS	Power-down save	DE	Destination
IP	IP address	Mac	Mac address	Date	Date parameter	Time	Time parameter	SMP	Slot,mnu,parameter	Chr	Character parameter	Ver	Version number

### 10.21.2 Slot 4 Menu 2: Ethernet configuration (Unidrive HS70 / HS72)

Parameter	Range			Default			Type						
	OL	RFC-A	RFC-S	OL	RFC-A	RFC-S							
4.02.003	Network Status	Initializing (0), Links Down (1), DHCP In Progress (2), No Address (3), Ready (4), Active (5)						RO	Txt	ND	NC	PT	
4.02.004	Network Message Count	0 to 65535						RO	Num	ND	NC	PT	
4.02.005	DHCP Enable	Off (0) or On (1)			On (1)			RW	Num				US
4.02.006	IP Address	0.0.0.0 to 255.255.255.255			192.168.001.100			RW	IP				US
4.02.007	Subnet Mask	0.0.0.0 to 255.255.255.255			255.255.255.000			RW	IP				US
4.02.008	Default Gateway	0.0.0.0 to 255.255.255.255			192.168.1.254			RW	IP				US
4.02.009	Primary DNS	0.0.0.0 to 255.255.255.255			0.0.0.0			RW	IP				US
4.02.010	Secondary DNS	0.0.0.0 to 255.255.255.255			0.0.0.0			RW	IP				US
4.02.011	MAC Address	00:00:00:00:00:00 to FF:FF:FF:FF:FF:FF						RO	Mac	ND	NC	PT	
4.02.020	Priority Protocol	None (0), Modbus TCP (1), EtherNet/IP (2)			0			RW	Txt				US
4.02.021	Web Server Enable	Off (0) or On (1)			On (1)			RW	Bit				US
4.02.022	Web Server Port	0 to 65535			80			RW	Num				US
4.02.024	Ethernet MTU	158 to 1500 Bytes			1500 Bytes			RW	Num				US
4.02.025	Gateway Mode	Switch (0), Gateway (1), Strict Gateway (2)			Switch (0)			RW	Txt				US
4.02.030	VLAN Enable	Off (0) or On (1)			Off (0)			RW	Bit				US
4.02.031	VLAN ID	0 to 255			0			RW	Num				US
4.02.035	Non cyclic enable	Off (0) or On (1)			Off (0)			RW	Bit				US
4.02.036	Non cyclic base parameter	0.00.000 to 0.59.999			0.00.000			RW	SMP				US

RW	Read / Write	RO	Read only	Num	Number parameter	Bit	Bit parameter	Txt	Text string	Bin	Binary parameter	FI	Filtered
ND	No default value	NC	Not copied	PT	Protected parameter	RA	Rating dependent	US	User save	PS	Power-down save	DE	Destination
IP	IP address	Mac	Mac address	Date	Date parameter	Time	Time parameter	SMP	Slot,mnu,parameter	Chr	Character parameter	Ver	Version number

### 10.21.3 Slot 4 Menu 9: Resources (Unidrive HS70 / HS72)

Parameter	Range			Default			Type						
	OL	RFC-A	RFC-S	OL	RFC-A	RFC-S	RO	Num	ND	NC			
4.09.001	Cyclic Tx Links Free	0 to 255						RO	Num	ND	NC		
4.09.002	Cyclic Rx Links Free	0 to 255						RO	Num	ND	NC		
4.09.003	Fieldbus Links Free	0 to 255						RO	Num	ND	NC		
4.09.004	Cyclic Mappings Free	0 to 255						RO	Num	ND	NC		
4.09.009	Idle Task % Free	0 to 255 %						RO	Num	ND	NC		
4.09.010	Synchronous Task % Free	0 to 255 %						RO	Num	ND	NC		
4.09.020	Synchronous Task % Worst Free	0 to 255 %						RO	Num	ND	NC		
4.09.030	PCB Temperature	-128 to 127 °C						RO	Num				

RW	Read / Write	RO	Read only	Num	Number parameter	Bit	Bit parameter	Txt	Text string	Bin	Binary parameter	FI	Filtered
ND	No default value	NC	Not copied	PT	Protected parameter	RA	Rating dependent	US	User save	PS	Power-down save	DE	Destination

### 10.21.4 Slot 4 Menu 10: Easy Mode (Unidrive HS70 / HS72)

Parameter	Range			Default			Type						
	OL	RFC-A	RFC-S	OL	RFC-A	RFC-S							
4.10.001	Enable	Off (0) or On (1)			On (1)			RW	Bit				US
4.10.002	Reset	Off (0) or On (1)			Off (0)			RW	Bit				
4.10.003	Default	Off (0) or On (1)			Off (0)			RW	Bit				
4.10.004	Message Rate	0 to 100 ms			0 ms			RW	Num				US
4.10.010	Tx1 Link Profile	0 to 0			0			RW	Num				US
4.10.011	Tx1 Link Number	0 to 255			0			RW	Num				US
4.10.012	Tx1 Source Parameter	0.00.000 to 4.99.999			0.00.000			RW	Num			PT	US
4.10.013	Tx1 Parameter Count	0 to 32			0			RW	Num				US
4.10.014	Tx1 Link Transmission Type	Unicast (0), Broadcast (1), Multicast1 (2), Multicast2 (3), Multicast3 (4), Multicast4 (5)			Unicast (0)			RW	Txt				US
4.10.015	Tx1 Destination Address	0.0.0.0 to 255.255.255.255			0.0.0.0			RW	IP	DE			US
4.10.019	Tx1 Link Status	Invalid profile (-16), Invalid mapping (-15), Read only param (-14), Timeout (-8), In error (-7), Link num in use (-6), Not editable (-5), Invalid link num (-4), Invalid args (-3), Too many links (-2), Out of memory (-1), OK (0)			OK (0)			RO	Txt				
4.10.020	Tx2 Link Profile	0 to 0			0			RW	Num				US
4.10.021	Tx2 Link Number	0 to 255			0			RW	Num				US
4.10.022	Tx2 Source Parameter	0.00.000 to 4.99.999			0.00.000			RW	Num			PT	US
4.10.023	Tx2 Parameter Count	0 to 32			0			RW	Num				US
4.10.024	Tx2 Link Transmission Type	Unicast (0), Broadcast (1), Multicast1 (2), Multicast2 (3), Multicast3 (4), Multicast4 (5)			Unicast (0)			RW	Txt				US
4.10.025	Tx2 Destination Address	0.0.0.0 to 255.255.255.255			0.0.0.0			RW	IP	DE			US
4.10.029	Tx2 Link Status	Invalid profile (-16), Invalid mapping (-15), Read only param (-14), Timeout (-8), In error (-7), Link num in use (-6), Not editable (-5), Invalid link num (-4), Invalid args (-3), Too many links (-2), Out of memory (-1), OK (0)			OK (0)			RO	Txt				
4.10.030	Tx3 Link Profile	0 to 0			0			RW	Num				US
4.10.031	Tx3 Link Number	0 to 255			0			RW	Num				US
4.10.032	Tx3 Source Parameter	0.00.000 to 4.99.999			0.00.000			RW	Num			PT	US
4.10.033	Tx3 Parameter Count	0 to 32			0			RW	Num				US
4.10.034	Tx3 Link Transmission Type	Unicast (0), Broadcast (1), Multicast1 (2), Multicast2 (3), Multicast3 (4), Multicast4 (5)			Unicast (0)			RW	Txt				US
4.10.035	Tx3 Destination Address	0.0.0.0 to 255.255.255.255			0.0.0.0			RW	IP	DE			US
4.10.039	Tx3 Link Status	Invalid profile (-16), Invalid mapping (-15), Read only param (-14), Timeout (-8), In error (-7), Link num in use (-6), Not editable (-5), Invalid link num (-4), Invalid args (-3), Too many links (-2), Out of memory (-1), OK (0)			OK (0)			RO	Txt				
4.10.040	Rx1 Link Profile	0 to 0			0			RW	Num				US
4.10.041	Rx1 Link Number	0 to 255			0			RW	Num				US
4.10.042	Rx1 Destination Parameter	0 to 4.99.999			0.00.000			RW	Num	DE			US
4.10.043	Rx1 Parameter Count	0 to 32			0.000			RW	Num				US
4.10.044	Rx1 Source Type	Direct (0), Multicast1 (1), Multicast2 (2), Multicast3 (3), Multicast4 (4), Local (5)			Direct (0)			RW	Txt				US
4.10.045	Rx1 Timeout	0 to 65535 ms			100 ms			RW	Num				US
4.10.046	Rx1 Timeout Action	Trip (0), Clear output (1), Hold last (2)			Trip (0)			RW	Txt				US
4.10.047	Rx1 Timeout Event Destination	This slot (0), Slot 1 (1), Slot 2 (2), Slot 3 (3), Slot 4 (4)			This slot (0)			RW	Txt				US
4.10.048	Rx1 Timeout Event Type	No event (0), Event (1), Event1 (2), Event2 (3), Event3 (4)			No event (0)			RW	Txt				US
4.10.049	Rx1 Link Status	Invalid profile (-16), Invalid mapping (-15), Read only param (-14), Timeout (-8), In error (-7), Link num in use (-6), Not editable (-5), Invalid link num (-4), Invalid args (-3), Too many links (-2), Out of memory (-1), OK (0)			OK (0)			RO	Txt				
4.10.050	Rx2 Link Profile	0 to 0			0			RW	Num				US
4.10.051	Rx2 Link Number	0 to 255			0			RW	Num				US
4.10.052	Rx2 Destination Parameter	0 to 4.99.999			0.00.000			RW	Num	DE			US
4.10.053	Rx2 Parameter Count	0 to 32			0			RW	Num				US

Safety information	Product information	Electrical installation	Getting started	Basic parameters	Running the motor	Optimization	NV Media Card Operation	Onboard PLC	<b>Advanced parameters</b>	Technical data	Diagnostics	UL listing information
--------------------	---------------------	-------------------------	-----------------	------------------	-------------------	--------------	-------------------------	-------------	----------------------------	----------------	-------------	------------------------

Parameter		Range			Default			Type						
		OL	RFC-A	RFC-S	OL	RFC-A	RFC-S							
4.10.054	Rx2 Source Type	Direct (0), Multicast1 (1), Multicast2 (2), Multicast3 (3), Multicast4 (4), Local (5)			Direct (0)			RW	Txt					US
4.10.055	Rx2 Timeout	0 to 65535 ms			100 ms			RW	Num					US
4.10.056	Rx2 Timeout Action	Trip (0), Clear output (1), Hold last (2)			Trip (0)			RW	Txt					US
4.10.057	Rx2 Timeout Event Destination	This slot (0), Slot 1 (1), Slot 2 (2), Slot 3 (3), Slot 4 (4)			This slot (0)			RW	Txt					US
4.10.058	Rx2 Timeout Event Type	No event (0), Event (1), Event1 (2), Event2 (3), Event3 (4)			No event (0)			RW	Txt					US
4.10.059	Rx2 Link Status	Invalid profile (-16), Invalid mapping (-15), Read only param (-14), Timeout (-8), In error (-7), Link num in use (-6), Not editable (-5), Invalid link num (-4), Invalid args (-3), Too many links (-2), Out of memory (-1), OK (0)			OK (0)			RO	Txt					
4.10.060	Rx3 Link Profile	0 to 0			0			RW	Num					US
4.10.061	Rx3 Link Number	0 to 255			0			RW	Num					US
4.10.062	Rx3 Destination Parameter	0.00.000 to 4.99.999			0.00.000			RW	Num	DE				US
4.10.063	Rx3 Parameter Count	0 to 32			0.000			RW	Num					US
4.10.064	Rx3 Source Type	Direct (0), Multicast1 (1), Multicast2 (2), Multicast3 (3), Multicast4 (4), Local (5)			Direct (0)			RW	Txt					US
4.10.065	Rx3 Timeout	0 to 65535 ms			100 ms			RW	Num					US
4.10.066	Rx3 Timeout Action	Trip (0), Clear output (1), Hold last (2)			Trip (0)			RW	Txt					US
4.10.067	Rx3 Timeout Event Destination	This slot (0), Slot 1 (1), Slot 2 (2), Slot 3 (3), Slot 4 (4)			This slot (0)			RW	Txt					US
4.10.068	Rx3 Timeout Event Type	No event (0), Event (1), Event1 (2), Event2 (3), Event3 (4)			No event (0)			RW	Txt					US
4.10.069	Rx3 Link Status	Invalid profile (-16), Invalid mapping (-15), Read only param (-14), Timeout (-8), In error (-7), Link num in use (-6), Not editable (-5), Invalid link num (-4), Invalid args (-3), Too many links (-2), Out of memory (-1), OK (0)			OK (0)			RO	Txt					

RW	Read / Write	RO	Read only	Num	Number parameter	Bit	Bit parameter	Txt	Text string	Bin	Binary parameter	FI	Filtered
ND	No default value	NC	Not copied	PT	Protected parameter	RA	Rating dependent	US	User save	PS	Power-down save	DE	Destination
IP	IP address	Mac	Mac address	Date	Date parameter	Time	Time parameter	SMP	Slot,menu,parameter	Chr	Character parameter	Ver	Version number

## 10.21.5 Slot 4 Menu 11: Synchronization (Unidrive HS70 / HS72)

Parameter	Range			Default			Type						
	OL	RFC-A	RFC-S	OL	RFC-A	RFC-S							
4.11.001	Preferred Sync Master	0 to 4			1			RW	Num				US
4.11.002	Master Clock Domain	0 to 3			0			RW	Num				US
4.11.005	Grandmaster MAC Address	00:00:00:00:00:00 to FF:FF:FF:FF:FF:FF						RO	Mac	ND	NC	PT	
4.11.006	Synchronization Jitter From Grandmaster	-2147483648 to 2147483647 ns						RO	Num	ND	NC	PT	
4.11.007	Synchronization Jitter Threshold	10 to 4294967295			1000			RW	Num				US
4.11.008	Module Synchronized Flag	Off (0) or On (1)			Off (0)			RO	Bit				
4.11.009	Inhibit Drive Synchronization	Off (0) or On (1)			Off (0)			RW	Bit				US
4.11.010	PTP Date	00-00-00 to 31-12-99						RO	Date	ND	NC	PT	
4.11.011	PTP Time	00:00:00 to 23:59:59						RO	Time	ND	NC	PT	
4.11.013	Network Transport Layer Select	802.3 (0), UDP (1)			UDP (1)			RW	Txt				US
4.11.014	1 Step Clock Correction	Off (0) or On (1)			Off (0)			RW	Bit				US
4.11.015	PTP Delay Measurement Select	E2E DELAY (0), P2P DELAY (1)			P2P DELAY (1)			RW	Txt				US
4.11.016	PTP Sync Rate	-4 to 4			-2			RW	Num				US
4.11.020	Network Error Count	0 to 4294967295						RO	Num	ND	NC	PT	
4.11.022	Interoption Sync Status	MASTER (0), PRODUCER (1), INDEPENDENT (2)						RO	Txt	ND	NC		
4.11.030	Tx1 Link Maximum Network Delay	0 to 100 ms			0 ms			RW	Num				US
4.11.031	Tx2 Link Maximum Network Delay	0 to 100 ms			0 ms			RW	Num				US
4.11.032	Tx3 Link Maximum Network Delay	0 to 100 ms			0 ms			RW	Num				US
4.11.040	Rx1 Late Synchronization Frame Action	Off (0), Trip (1), Do not use (2), Use (3)			Off (0)			RW	Txt				US
4.11.041	Rx1 Late Synchronization Frame Destination	This slot (0), Slot 1 (1), Slot 2 (2), Slot 3 (3), Slot 4 (4)			This slot (0)			RW	Txt				US
4.11.042	Rx1 Late Synchronization Frame Event	No event (0), Event (1), Event1 (2), Event2 (3), Event3 (4)			No event (0)			RW	Txt				US
4.11.050	Rx2 Late Synchronization Frame Action	Off (0), Trip (1), Do not use (2), Use (3)			Off (0)			RW	Txt				US
4.11.051	Rx2 Late Synchronization Frame Destination	This slot (0), Slot 1 (1), Slot 2 (2), Slot 3 (3), Slot 4 (4)			This slot (0)			RW	Txt				US
4.11.052	Rx2 Late Synchronization Frame Event	No event (0), Event (1), Event1 (2), Event2 (3), Event3 (4)			No event (0)			RW	Txt				US
4.11.060	Rx3 Late Synchronization Frame Action	Off (0), Trip (1), Do not use (2), Use (3)			Off (0)			RW	Txt				US
4.11.061	Rx3 Late Synchronization Frame Destination	This slot (0), Slot 1 (1), Slot 2 (2), Slot 3 (3), Slot 4 (4)			This slot (0)			RW	Txt				US
4.11.062	Rx3 Late Synchronization Frame Event	No event (0), Event (1), Event1 (2), Event2 (3), Event3 (4)			No event (0)			RW	Txt				US

RW	Read / Write	RO	Read only	Num	Number parameter	Bit	Bit parameter	Txt	Text string	Bin	Binary parameter	Fl	Filtered
ND	No default value	NC	Not copied	PT	Protected parameter	RA	Rating dependent	US	User save	PS	Power-down save	DE	Destination
IP	IP address	Mac	Mac address	Date	Date parameter	Time	Time parameter	SMP	Slot,menu,parameter	Chr	Character parameter	Ver	Version number

### 10.21.6 Slot 4 Menu 15: Modbus (Unidrive HS70 / HS72)

Parameter	Range			Default			Type						
	OL	RFC-A	RFC-S	OL	RFC-A	RFC-S							
4.15.001	Enable	Off (0) or On (1)			On (1)			RW	Bit				US
4.15.002	Reset	Off (0) or On (1)			Off (0)			RW	Bit				
4.15.003	Default	Off (0) or On (1)			Off (0)			RW	Bit				
4.15.004	Modbus Configuration Error	No error (0), Port in use (1), Timeout event (2)						RO	Txt				
4.15.005	Modbus Listening Port	0 to 65535			502			RW	Num				
4.15.006	Maximum Connections	0 to 4			2			RW	Num				US
4.15.007	Maximum Priority Connections	0 to 4			1			RW	Num				US
4.15.008	Maximum Connections Per Client	1 to 4			2			RW	Num				US
4.15.009	Modbus Timeout	1 to 10000 ms			100 ms			RW	Num				US
4.15.010	Modbus Timeout Action	Trip (0), No action (1)			No action (1)			RW	Txt				US
4.15.011	Modbus Timeout Event Destination	This slot (0), Slot 1 (1), Slot 2 (2), Slot 3 (3), Slot 4 (4)			This slot (0)			RW	Txt				US
4.15.012	Modbus Timeout Event Type	No event (0), Trigger Event (1), Trigger Event 1 (2), Trigger Event 2 (3), Trigger Event 3 (4), Trigger Event 4 (5)			No event (0)			RW	Txt				US
4.15.013	Modbus Resister Addressing Mode	Standard (0), Modified (1)			Standard (0)			RW	Txt				US
4.15.020	Priority Connection 1	0.0.0.0 to 255.255.255.255			0.0.0.0			RW	IP				US
4.15.021	Priority Connection 2	0.0.0.0 to 255.255.255.255			0.0.0.0			RW	IP				US
4.15.022	Priority Connection 3	0.0.0.0 to 255.255.255.255			0.0.0.0			RW	IP				US
4.15.023	Priority Connection 4	0.0.0.0 to 255.255.255.255			0.0.0.0			RW	IP				US

RW	Read / Write	RO	Read only	Num	Number parameter	Bit	Bit parameter	Txt	Text string	Bin	Binary parameter	FI	Filtered
ND	No default value	NC	Not copied	PT	Protected parameter	RA	Rating dependent	US	User save	PS	Power-down save	DE	Destination
IP	IP address	Mac	Mac address	Date	Date parameter	Time	Time parameter	SMP	Slot,menu,parameter	Chr	Character parameter	Ver	Version number

### 10.21.7 Slot 4 Menu 20: EtherNet/IP (Unidrive HS70 / HS72)

Parameter	Range			Default			Type						
	OL	RFC-A	RFC-S	OL	RFC-A	RFC-S							
4.20.001	Enable EtherNet/IP	Off (0) or On (1)			On (1)			RW	Bit				US
4.20.002	Reset	Off (0) or On (1)			Off (0)			RW	Bit				
4.20.003	Default	Off (0) or On (1)			Off (0)			RW	Bit				
4.20.004	Configuration Error	No error (0), RPI event dst (1), RPI event type (2), IDLE event dst (3), IDLE event type (4), Input mapping (5), Output mapping (6), In cons trig pr (7), Out cons trig pr (8)						RO	Txt	ND			
4.20.007	Cyclic Data Transfers Per Second	0 to 65535						RO	Num	ND	NC	PT	
4.20.011	RPI Timeout Action	Trip (0), Send fit values (1), Clear output (2), Hold last (3), No Action (4)			Hold last (3)			RW	Txt				US
4.20.012	RPI Timeout Event Destination	This slot (0), Slot 1 (1), Slot 2 (2), Slot 3 (3), Slot 4 (4)			This slot (0)			RW	Txt				US
4.20.013	RPI Timeout Event Type	No event (0), Trigger Event (1), Trigger Event 1 (2), Trigger Event 2 (3), Trigger Event 3 (4), Trigger Event 4 (5)			No event (0)			RW	Txt				US
4.20.015	PLC Idle Action	Trip (0), Send fit values (1), Clear output (2), Hold last (3), No Action (4)			No Action (4)			RW	Txt				US
4.20.016	PLC Idle Event Destination	This slot (0), Slot 1 (1), Slot 2 (2), Slot 3 (3), Slot 4 (4)			This slot (0)			RW	Txt				US
4.20.017	PLC Idle Event Type	No event (0), Trigger Event (1), Trigger Event 1 (2), Trigger Event 2 (3), Trigger Event 3 (4), Trigger Event 4 (5)			No event (0)			RW	Txt				US
4.20.018	Active Input Assembly Object	100-PrimaryI (0), 70-BscSpdCtrl (1), 71-ExtSpdCtrl (2), 72-SpdTqCtrl (3), 73-ExtSpdTqCtrl (4)			100-PrimaryI (0)			RO	Txt				
4.20.019	Active Output Assembly Object	101-PrimaryO (0), 20-BscSpdCtrlO (1), 21-ExtSpdCtrlO (2), 22-SpdTqCtrlO (3), 23-ExtSpdTqCtrlO (4)			101-PrimaryO (0)			RO	Txt				
4.20.020	Input Assembly Object Size	4 to 80			8			RW	Num				
4.20.021	Output Assembly Object Size	4 to 80			8			RW	Num				US
4.20.024	Input Assembly Object Process Time	0 to 65535						RO	Num	ND	NC		
4.20.025	Output Assembly Object Process Time	0 to 65535						RO	Num	ND	NC		
4.20.026	Input Assembly Object Consistency Enable	Off (0) or On (1)			Off (0)			RW	Bit				US
4.20.027	Input Assembly Object Consistency Trigger Parameter	0.00.000 to 4.99.999			0.00.000			RW	Num				
4.20.028	Input Assembly Object Consistency Enable	Off (0) or On (1)			Off (0)			RW	Bit				US
4.20.029	Output Assembly Object Consistency Trigger Parameter	0.00.000 to 4.99.999			0.00.000			RW	Num				US
4.20.030	Custom Vender ID	257 - CT (0), 553 - CT America (1)			257-CT (0)			RW	Txt				
4.20.031	Custom product code	0 to 65535			0			RW	Num				US
4.20.032	Custom product revision code	0 to 65535			0			RW	Num				US
4.20.033	Actual Product Code	0 to 65535			0			RO	Num				
4.20.034	Actual Product Revision	0 to 65535			0								
4.20.040	Type of Motor 1	2-FC DC (0), 6-WRI (1), 7-SCI (2), 9-Sin PM BL (3), 10-Trap PM BL (4)			7-SCI (2)			RO	Txt			PT	US
4.20.041	Type of Motor 2	2-FC DC (0), 6-WRI (1), 7-SCI (2), 9-Sin PM BL (3), 10-Trap PM BL (4)			7-SCI (2)			RO	Txt			PT	US

RW	Read/Write	RO	Read only	Num	Number parameter	Bit	Bit parameter	Txt	Text string	Bin	Binary parameter	FI	Filtered
ND	No default value	NC	Not copied	PT	Protected parameter	RA	Rating dependent	US	User save	PS	Power-down save	DE	Destination

### 10.21.8 Slot 4 Menu 21: EtherNet/IP In Mappings (Unidrive HS70 / HS72)

Parameter	Range			Default			Type						
	OL	RFC-A	RFC-S	OL	RFC-A	RFC-S							
4.21.001	Input Mapping Parameter 1	0.00.000 to 4.99.999			0.10.040			RW	Num	DE		PT	US
4.21.002	Input Mapping Parameter 2	0.00.000 to 4.99.999			0.02.001			RW	Num	DE		PT	US
4.21.003	Input Mapping Parameter 3	0.00.000 to 4.99.999			0.00.000			RW	Num	DE		PT	US
4.21.004	Input Mapping Parameter 4	0.00.000 to 4.99.999			0.00.000			RW	Num	DE		PT	US
4.21.005	Input Mapping Parameter 5	0.00.000 to 4.99.999			0.00.000			RW	Num	DE		PT	US
4.21.006	Input Mapping Parameter 6	0.00.000 to 4.99.999			0.00.000			RW	Num	DE		PT	US
4.21.007	Input Mapping Parameter 7	0.00.000 to 4.99.999			0.00.000			RW	Num	DE		PT	US
4.21.008	Input Mapping Parameter 8	0.00.000 to 4.99.999			0.00.000			RW	Num	DE		PT	US
4.21.009	Input Mapping Parameter 9	0.00.000 to 4.99.999			0.00.000			RW	Num	DE		PT	US
4.21.010	Input Mapping Parameter 10	0.00.000 to 4.99.999			0.00.000			RW	Num	DE		PT	US
4.21.011	Input Mapping Parameter 11	0.00.000 to 4.99.999			0.00.000			RW	Num	DE		PT	US
4.21.012	Input Mapping Parameter 12	0.00.000 to 4.99.999			0.00.000			RW	Num	DE		PT	US
4.21.013	Input Mapping Parameter 13	0.00.000 to 4.99.999			0.00.000			RW	Num	DE		PT	US
4.21.014	Input Mapping Parameter 14	0.00.000 to 4.99.999			0.00.000			RW	Num	DE		PT	US
4.21.015	Input Mapping Parameter 15	0.00.000 to 4.99.999			0.00.000			RW	Num	DE		PT	US
4.21.016	Input Mapping Parameter 16	0.00.000 to 4.99.999			0.00.000			RW	Num	DE		PT	US
4.21.017	Input Mapping Parameter 17	0.00.000 to 4.99.999			0.00.000			RW	Num	DE		PT	US
4.21.018	Input Mapping Parameter 18	0.00.000 to 4.99.999			0.00.000			RW	Num	DE		PT	US
4.21.019	Input Mapping Parameter 19	0.00.000 to 4.99.999			0.00.000			RW	Num	DE		PT	US
4.21.020	Input Mapping Parameter 20	0.00.000 to 4.99.999			0.00.000			RW	Num	DE		PT	US

RW	Read / Write	RO	Read only	Num	Number parameter	Bit	Bit parameter	Txt	Text string	Bin	Binary parameter	FI	Filtered
ND	No default value	NC	Not copied	PT	Protected parameter	RA	Rating dependent	US	User save	PS	Power-down save	DE	Destination

### 10.21.9 Slot 4 Menu 22: EtherNet/IP Out Mappings (Unidrive HS70 / HS72)

Parameter	Range			Default			Type						
	OL	RFC-A	RFC-S	OL	RFC-A	RFC-S							
4.22.001	Output Mapping Parameter 1	0.00.000 to 4.99.999			0.06.042			RW	Num	DE		PT	US
4.22.002	Output Mapping Parameter 2	0.00.000 to 4.99.999			0.01.021			RW	Num	DE		PT	US
4.22.003	Output Mapping Parameter 3	0.00.000 to 4.99.999			0.00.000			RW	Num	DE		PT	US
4.22.004	Output Mapping Parameter 4	0.00.000 to 4.99.999			0.00.000			RW	Num	DE		PT	US
4.22.005	Output Mapping Parameter 5	0.00.000 to 4.99.999			0.00.000			RW	Num	DE		PT	US
4.22.006	Output Mapping Parameter 6	0.00.000 to 4.99.999			0.00.000			RW	Num	DE		PT	US
4.22.007	Output Mapping Parameter 7	0.00.000 to 4.99.999			0.00.000			RW	Num	DE		PT	US
4.22.008	Output Mapping Parameter 8	0.00.000 to 4.99.999			0.00.000			RW	Num	DE		PT	US
4.22.009	Output Mapping Parameter 9	0.00.000 to 4.99.999			0.00.000			RW	Num	DE		PT	US
4.22.010	Output Mapping Parameter 10	0.00.000 to 4.99.999			0.00.000			RW	Num	DE		PT	US
4.22.011	Output Mapping Parameter 11	0.00.000 to 4.99.999			0.00.000			RW	Num	DE		PT	US
4.22.012	Output Mapping Parameter 12	0.00.000 to 4.99.999			0.00.000			RW	Num	DE		PT	US
4.22.013	Output Mapping Parameter 13	0.00.000 to 4.99.999			0.00.000			RW	Num	DE		PT	US
4.22.014	Output Mapping Parameter 14	0.00.000 to 4.99.999			0.00.000			RW	Num	DE		PT	US
4.22.015	Output Mapping Parameter 15	0.00.000 to 4.99.999			0.00.000			RW	Num	DE		PT	US
4.22.016	Output Mapping Parameter 16	0.00.000 to 4.99.999			0.00.000			RW	Num	DE		PT	US
4.22.017	Output Mapping Parameter 17	0.00.000 to 4.99.999			0.00.000			RW	Num	DE		PT	US
4.22.018	Output Mapping Parameter 18	0.00.000 to 4.99.999			0.00.000			RW	Num	DE		PT	US
4.22.019	Output Mapping Parameter 19	0.00.000 to 4.99.999			0.00.000			RW	Num	DE		PT	US
4.22.020	Output Mapping Parameter 20	0.00.000 to 4.99.999			0.00.000			RW	Num	DE		PT	US

RW	Read / Write	RO	Read only	Num	Number parameter	Bit	Bit parameter	Txt	Text string	Bin	Binary parameter	FI	Filtered
ND	No default value	NC	Not copied	PT	Protected parameter	RA	Rating dependent	US	User save	PS	Power-down save	DE	Destination

### 10.21.10 Slot 4 Menu 23: EtherNet/IP Fault Values (*Unidrive HS70 / HS72*)

Parameter		Range			Default			Type					
		OL	RFC-A	RFC-S	OL	RFC-A	RFC-S						
4.23.001	Output Fault Value 1	-2147483648 to 2147483647			0			RW	Num			PT	US
4.23.002	Output Fault Value 2	-2147483648 to 2147483647			0			RW	Num			PT	US
4.23.003	Output Fault Value 3	-2147483648 to 2147483647			0			RW	Num			PT	US
4.23.004	Output Fault Value 4	-2147483648 to 2147483647			0			RW	Num			PT	US
4.23.005	Output Fault Value 5	-2147483648 to 2147483647			0			RW	Num			PT	US
4.23.006	Output Fault Value 6	-2147483648 to 2147483647			0			RW	Num			PT	US
4.23.007	Output Fault Value 7	-2147483648 to 2147483647			0			RW	Num			PT	US
4.23.008	Output Fault Value 8	-2147483648 to 2147483647			0			RW	Num			PT	US
4.23.009	Output Fault Value 9	-2147483648 to 2147483647			0			RW	Num			PT	US
4.23.010	Output Fault Value 10	-2147483648 to 2147483647			0			RW	Num			PT	US
4.23.011	Output Fault Value 11	-2147483648 to 2147483647			0			RW	Num			PT	US
4.23.012	Output Fault Value 12	-2147483648 to 2147483647			0			RW	Num			PT	US
4.23.013	Output Fault Value 13	-2147483648 to 2147483647			0			RW	Num			PT	US
4.23.014	Output Fault Value 14	-2147483648 to 2147483647			0			RW	Num			PT	US
4.23.015	Output Fault Value 15	-2147483648 to 2147483647			0			RW	Num			PT	US
4.23.016	Output Fault Value 16	-2147483648 to 2147483647			0			RW	Num			PT	US
4.23.017	Output Fault Value 17	-2147483648 to 2147483647			0			RW	Num			PT	US
4.23.018	Output Fault Value 18	-2147483648 to 2147483647			0			RW	Num			PT	US
4.23.019	Output Fault Value 19	-2147483648 to 2147483647			0			RW	Num			PT	US
4.23.020	Output Fault Value 20	-2147483648 to 2147483647			0			RW	Num			PT	US

RW	Read / Write	RO	Read only	Num	Number parameter	Bit	Bit parameter	Txt	Text string	Bin	Binary parameter	Fl	Filtered
ND	No default value	NC	Not copied	PT	Protected parameter	RA	Rating dependent	US	User save	PS	Power-down save	DE	Destination

# 11 Technical data

## 11.1 Drive technical data

### 11.1.1 Supply requirements

AC supply voltage:

- 200 V drive: 200 V to 240 V  $\pm 10$  %
- 400 V drive: 380 V to 480 V  $\pm 10$  %
- 575 V drive: 500 V to 575 V  $\pm 10$  %
- 690 V drive: 500 V to 690 V  $\pm 10$  %

Number of phases: 3

Maximum supply imbalance: 2 % negative phase sequence (equivalent to 3 % voltage imbalance between phases).

Frequency range: 45 to 66 Hz

For UL compliance only, the maximum supply symmetrical fault current must be limited to 100 kA

### 11.1.2 Line reactors

Input line reactors reduce the risk of damage to the drive resulting from poor phase balance or severe disturbances on the supply network.

Where line reactors are to be used, reactance values of approximately 2 % are recommended. Higher values may be used if necessary, but may result in a loss of drive output (reduced torque at high speed) because of the voltage drop.

For all drive ratings, 2 % line reactors permit drives to be used with a supply unbalance of up to 3.5 % negative phase sequence (equivalent to 5% voltage imbalance between phases).

Severe disturbances may be caused by the following factors, for example:

- Power factor correction equipment connected close to the drive.
- Large DC drives having no or inadequate line reactors connected to the supply.
- Across the line (DOL) started motor(s) connected to the supply such that when any of these motors are started, the voltage dip exceeds 20 %.

Such disturbances may cause excessive peak currents to flow in the input power circuit of the drive. This may cause nuisance tripping, or in extreme cases, failure of the drive.

Drives of low power rating may also be susceptible to disturbance when connected to supplies with a high rated capacity.

When required, each drive must have its own reactor(s). Three individual reactors or a single three-phase reactor should be used.

### Reactor current ratings

The current rating of the line reactors should be as follows:

Continuous current rating:

Not less than the continuous input current rating of the drive

Repetitive peak current rating:

Not less than twice the continuous input current rating of the drive

### 11.1.3 Motor requirements

No. of phases: 3

Maximum voltage:

- 200 V drive: 240 V
- 400 V drive: 480 V
- 575 V drive: 575 V
- 690 V drive: 690 V

### 11.1.4 Temperature, humidity and cooling method

Ambient temperature operating range:

- 20 °C to 50 °C (- 4 °F to 122 °F).
- Output current derating must be applied at ambient temperatures >40 °C (104 °F).

Cooling method: Forced convection

Maximum humidity: 95 % non-condensing at 40 °C (104 °F)

### 11.1.5 Storage

-40 °C (-40 °F) to +50 °C (122 °F) for long term storage, or to +70 °C (158 °F) for short term storage.

Storage time is 2 years.

Electrolytic capacitors in any electronic product have a storage period after which they require reforming or replacing.

The DC bus capacitors have a storage period of 10 years.

The low voltage capacitors on the control supplies typically have a storage period of 2 years and are thus the limiting factor.

Low voltage capacitors cannot be reformed due to their location in the circuit and thus may require replacing if the drive is stored for a period of 2 years or greater without power being applied.

It is therefore recommended that drives are powered up for a minimum of 1 hour after every 2 years of storage.

This process allows the drive to be stored for a further 2 years.

### 11.1.6 Altitude

Altitude range: 0 to 3,000 m (9,900 ft), subject to the following conditions:

1,000 m to 3,000 m (3,300 ft to 9,900 ft) above sea level: de-rate the maximum output current from the specified figure by 1% per 100 m (330 ft) above 1,000 m (3,300 ft)

For example at 3,000 m (9,900 ft) the output current of the drive would have to be de-rated by 20 %.

### 11.1.7 IP / UL Rating

The drive is rated to IP20 pollution degree 2 (dry, non-conductive contamination only) (NEMA 1). However, it is possible to configure the drive to achieve IP65 rating (NEMA 12) at the rear of the heatsink for through-panel mounting (some current derating is required).

In order to achieve the high IP rating at the rear of the heatsink with drive sizes 3, 4 and 5 it is necessary to seal a heatsink vent by installing the high IP insert.

The IP rating of a product is a measure of protection against ingress and contact to foreign bodies and water. It is stated as IP XX, where the two digits (XX) indicate the degree of protection provided as shown in Table 11-1.

**Table 11-1 IP Rating degrees of protection**

First digit	Second digit
Protection against contact and ingress of foreign bodies	Protection against ingress of water
0 No protection	0 No protection
1 Protection against large foreign bodies $\phi > 50$ mm (large area contact with the hand)	1 Protection against vertically falling drops of water
2 Protection against medium size foreign bodies $\phi > 12$ mm (finger)	2 Protection against spraywater (up to 15 ° from the vertical)
3 Protection against small foreign bodies $\phi > 2.5$ mm (tools, wires)	3 Protection against spraywater (up to 60 ° from the vertical)
4 Protection against granular foreign bodies $\phi > 1$ mm (tools, wires)	4 Protection against splashwater (from all directions)
5 Protection against dust deposit, complete protection against accidental contact.	5 Protection against heavy splash water (from all directions, at high pressure)
6 Protection against dust ingress, complete protection against accidental contact.	6 Protection against deckwater (e.g. in heavy seas)
7 -	7 Protection against immersion
8 -	8 Protection against submersion

**Table 11-2 UL enclosure ratings**

UL rating	Description
Type 1	Enclosures are intended for indoor use, primarily to provide a degree of protection against limited amounts of falling dirt.
Type 12	Enclosures are intended for indoor use, primarily to provide a degree of protection against dust, falling dirt and dripping non-corrosive liquids.

### 11.1.8 Corrosive gasses

Concentrations of corrosive gases must not exceed the levels given in:

- Table A2 of EN 50178:1998
- Class 3C2 of IEC 60721-3-3

This corresponds to the levels typical of urban areas with industrial activities and/or heavy traffic, but not in the immediate neighborhood of industrial sources with chemical emissions.

### 11.1.9 RoHS compliance

The drive meets EU directive 2002-95-EC for RoHS compliance.

### 11.1.10 Vibration

Maximum recommended continuous vibration level 0.14 g r.m.s. broad-band 5 to 200 Hz.

#### NOTE

This is the limit for broad-band (random) vibration. Narrow-band vibration at this level which coincides with a structural resonance could result in premature failure.

#### Bump Test

Testing in each of three mutually perpendicular axes in turn.  
Referenced standard: IEC 60068-2-27  
Severity: 18 g, 6 ms, half sine  
No. of Bumps: 600 (100 in each direction of each axis)

#### Random Vibration Test

Testing in each of three mutually perpendicular axes in turn.  
Referenced standard: IEC 60068-2-64: Test Fh:  
Severity: 1.0 m<sup>2</sup>/s<sup>3</sup> (0.01 g<sup>2</sup>/Hz) ASD from 5 to 20 Hz  
-3 dB/octave from 20 to 200 Hz  
Duration: 30 minutes in each of 3 mutually perpendicular axes.

#### Sinusoidal Vibration Test

Testing in each of three mutually perpendicular axes in turn.  
Referenced standard: IEC 60068-2-6: Test Fc:  
Frequency range: 5 to 500 Hz  
Severity: 3.5 mm peak displacement from 5 to 9 Hz  
10 m/s<sup>2</sup> peak acceleration from 9 to 200 Hz  
15 m/s<sup>2</sup> peak acceleration from 200 to 500 Hz  
Sweep rate: 1 octave/minute  
Duration: 15 minutes in each of 3 mutually perpendicular axes.  
EN 61800-5-1:2007, Section 5.2.6.4. referring to IEC 60068-2-6  
Frequency range: 10 to 150 Hz  
Amplitude: 10 to 57 Hz at 0.075 mm pk  
57 to 150 Hz at 1g p  
Sweep rate: 1 octave/minute  
Duration: 10 sweep cycles per axis in each of 3 mutually perpendicular axes

### 11.1.11 Starts per hour

By electronic control: unlimited  
By interrupting the AC supply: ≤20 (equally spaced)

### 11.1.12 Start up time

This is the time taken from the moment of applying power to the drive, to the drive being ready to run the motor:

Sizes 3:

### 11.1.13 Output frequency / speed range

In all open loop mode the maximum achievable output frequency is 3,000 Hz.

In RFC-A and RFC-S modes, the maximum achievable output frequency is 1,250Hz.

In RFC-S mode the speed is also limited by the voltage constant (Ke) of the motor unless field weakening operation is enabled. Ke is a specific constant for the servo motor being used. It can normally be found on the motor data sheet in V/k rpm (volts per 1,000 rpm).

It is recommended that a minimum ratio of 12:1 is maintained between the switching frequency and the maximum output frequency to maintain the quality of the output waveform. If this minimum ratio is exceeded, extra motor losses will result due to the increased harmonic content of the output waveform.

### 11.1.14 Accuracy and resolution

#### Speed:

The absolute frequency and speed accuracy depends on the accuracy of the crystal used with the drive microprocessor. The accuracy of the crystal is 100 ppm, and so the absolute frequency/speed accuracy is 100 ppm (0.01 %) of the reference, when a preset speed is used. If an analog input is used the absolute accuracy is further limited by the absolute accuracy of the analog input.

The following data applies to the drive only; it does not include the performance of the source of the control signals.

Open loop resolution:

Preset frequency reference: 0.1 Hz  
Precision frequency reference: 0.001 Hz

Closed loop resolution

Preset speed reference: 0.1 rpm  
Precision speed reference: 0.001 rpm  
Analog input 1: 11 bit plus sign (not applicable to *Unidrive HS72*)  
Analog input 2: 11 bit plus sign (not applicable to *Unidrive HS72*)

#### Current:

The resolution of the current feedback is 10 bit plus sign.

Accuracy: typical 2 %

worst case 5 %

### 11.1.15 SAFE TORQUE OFF data

Data as verified by TÜV Rheinland:

According to EN ISO 13849-1:

PL = e

Category = 4

MTTF<sub>D</sub> = High

DC<sub>av</sub> = High

Mission Time and Proof Test Interval = 20 years

The calculated MTTF<sub>D</sub> for the complete STO function is:

STO1 2574 yr

STO2 2716 yr (for *Unidrive HS72* only)

According to EN 61800-5-2:

SIL = 3

PFH = 4.21 x 10<sup>-11</sup> h<sup>-1</sup>

Logic levels comply with IEC 61131-2:2007 for type 1 digital inputs rated at 24 V. Maximum level for logic low to achieve SIL3 and PL e 5 V and 0.5 mA.

### 11.1.16 Electromagnetic compatibility (EMC)

This is a summary of the EMC performance of the drive. For full details, refer to the *EMC Data Sheet* which can be obtained from the supplier of the drive.

**Table 11-3 Immunity compliance**

Standard	Type of immunity	Test specification	Application	Level
IEC61000-4-2 EN61000-4-2	Electrostatic discharge	6 kV contact discharge 8 kV air discharge	Module enclosure	Level 3 (industrial)
IEC61000-4-3 EN61000-4-3	Radio frequency radiated field	10 V/m prior to modulation 80 - 1000 MHz 80 % AM (1 kHz) modulation	Module enclosure	Level 3 (industrial)
IEC61000-4-4 EN61000-4-4	Fast transient burst	5/50 ns 2 kV transient at 5 kHz repetition frequency via coupling clamp	Control lines	Level 4 (industrial harsh)
		5/50 ns 2 kV transient at 5 kHz repetition frequency by direct injection	Power lines	Level 3 (industrial)
IEC61000-4-5 EN61000-4-5	Surges	Common mode 4 kV 1.2/50 µs waveshape	AC supply lines: line to ground	Level 4
		Differential mode 2 kV 1.2/50 µs waveshape	AC supply lines: line to line	Level 3
		Lines to ground	Signal ports to ground <sup>1</sup>	Level 2
IEC61000-4-6 EN61000-4-6	Conducted radio frequency	10V prior to modulation 0.15 - 80 MHz 80 % AM (1 kHz) modulation	Control and power lines	Level 3 (industrial)
IEC61000-4-11 EN61000-4-11	Voltage dips and interruptions	-30 % 10 ms +60 % 100 ms -60 % 1 s <-95 % 5 s	AC power ports	
IEC61000-6-1 EN61000-6-1:2007	Generic immunity standard for the residential, commercial and light - industrial environment			Complies
IEC61000-6-2 EN61000-6-2:2005	Generic immunity standard for the industrial environment			Complies
IEC61800-3 EN61800-3:2004	Product standard for adjustable speed power drive systems (immunity requirements)		Meets immunity requirements for first and second environments	

<sup>1</sup> See EMC data sheet section surge immunity of control circuits - long cables and connections outside a building for control ports for possible requirements regarding grounding and external surge protection.

#### Emission

The drive contains an in-built filter for basic emission control. An additional optional external filter provides further reduction of emission. The requirements of the following standards are met, depending on the motor cable length and switching frequency.

**Table 11-4 Size 3 emission compliance (200 V drives)**

Motor cable length (m)	Switching frequency (kHz)					
	3	4	6	8	12	16
Using internal filter:						
0 - 2	C3		C4			
Using internal filter and external ferrite ring (1 turn):						
0 - 10	C3			C4		
10 - 20	C3		C4			
Using external filter:						
0 - 20	R					
20 - 100		-	-	-	-	-

**Table 11-5 Size 3 emission compliance (400 V drives)**

Motor cable length (m)	Switching frequency (kHz)					
	3	4	6	8	12	16
Using internal filter:						
0 - 5	C3		C4			
Using internal filter and external ferrite ring (2 turns):						
0 - 10	C3			C4		
Using external filter:						
0 - 20	R					
20 - 100		-	-	-	-	-

**Key** (shown in decreasing order of permitted emission level):

- E2R EN 61800-3:2004 second environment, restricted distribution (Additional measures may be required to prevent interference)
- E2U EN 61800-3:2004 second environment, unrestricted distribution
- I Industrial generic standard EN 61000-6-4:2007  
EN 61800-3:2004 first environment restricted distribution (The following caution is required by EN 61800-3:2004)



This is a product of the restricted distribution class according to IEC 61800-3. In a residential environment this product may cause radio interference in which case the user may be required to take adequate measures.

- R Residential generic standard EN 61000-6-3:2007  
EN 61800-3:2004 first environment unrestricted distribution

EN 61800-3:2004 defines the following:

- The first environment is one that includes residential premises. It also includes establishments directly connected without intermediate transformers to a low-voltage power supply network which supplies buildings used for residential purposes.
- The second environment is one that includes all establishments other than those directly connected to a low-voltage power supply network which supplies buildings used for residential purposes.
- Restricted distribution is defined as a mode of sales distribution in which the manufacturer restricts the supply of equipment to suppliers, customers or users who separately or jointly have technical competence in the EMC requirements of the application of drives.

#### IEC 61800-3:2004 and EN 61800-3:2004

The 2004 revision of the standard uses different terminology to align the requirements of the standard better with the EC EMC Directive.

Power drive systems are categorized C1 to C4:

Category	Definition	Corresponding code used above
C1	Intended for use in the first or second environments	R
C2	Not a plug-in or movable device, and intended for use in the first environment only when installed by a professional, or in the second environment	I
C3	Intended for use in the second environment, not the first environment	E2U
C4	Rated at over 1000 V or over 400 A, intended for use in complex systems in the second environment	E2R

Note that category 4 is more restrictive than E2R, since the rated current of the PDS must exceed 400 A or the supply voltage exceed 1000 V, for the complete PDS.

# 12 Diagnostics

The keypad display on the drive gives various information about the status of the drive. The keypad display provides information on the following categories:

- Trip indications
- Alarm indications
- Status indications



Users must not attempt to repair a drive if it is faulty, nor carry out fault diagnosis other than through the use of the diagnostic features described in this chapter. If a drive is faulty, it must be returned to an authorized Control Techniques distributor for repair.

## 12.1 Status modes (Keypad and LED status)

Figure 12-1 Keypad status modes

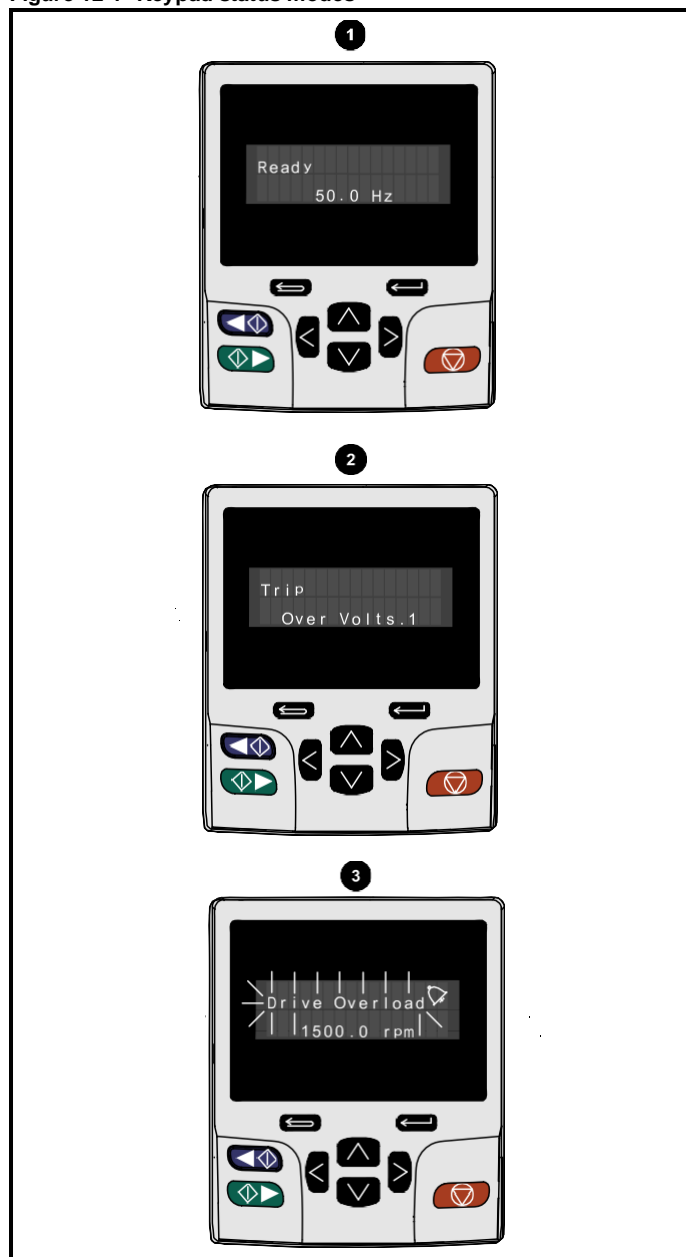

1. Drive OK status
2. Trip status
3. Alarm status

Figure 12-2 Location of the status LED

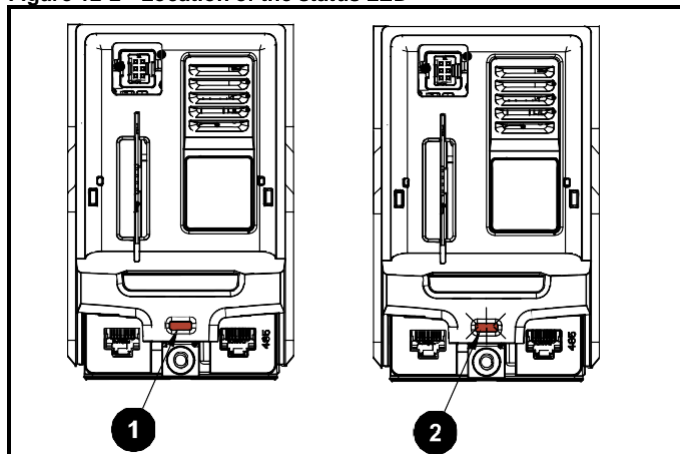

1. Non flashing: Normal status
2. Flashing: Trip status

### 12.1.1 Unidrive HS70 / HS72 Ethernet status LED

Each of the Ethernet ports provide a status LED for diagnostic and information purposes. Refer to Table 12-1 for Ethernet LED status.

Figure 12-3 Ethernet port status LED

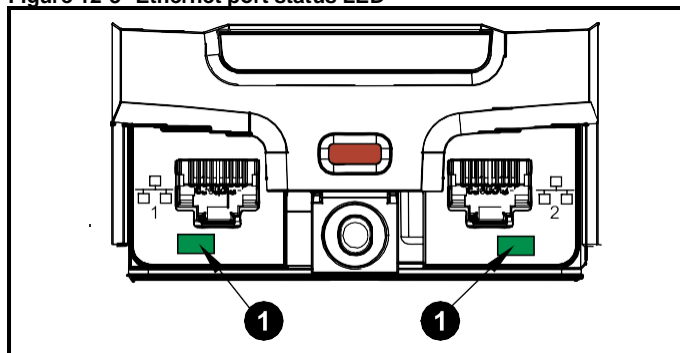

1. Ethernet port status LED.

Table 12-1 Ethernet LED status

LED status	Description
Off	Ethernet connection not detected
Solid green	Ethernet connection detected but no data
Flashing green	Ethernet connection detected and data flow

## 12.2 Trip indications

The output of the drive is disabled under any trip condition so that the drive stops controlling the motor. If the motor is running when the trip occurs it will coast to a stop.

During a trip condition, where a KI-Keypad is being used, the upper row of the display indicates that a trip has occurred and the lower row of the keypad display will display the trip string. Some trips have a sub-trip number to provide additional information about the trip. If a trip has a sub-trip number, the sub-trip number is flashed alternately with the trip string unless there is space on the second row for both the trip string and the sub-trip number in which case both the trip string and sub-trip information is displayed separated by a decimal place.

The back-light of the KI-Keypad display will also flash during a trip condition. If a display is not being used, the drive LED Status indicator will flash with 0.5 s duty cycle if the drive has tripped. Refer to Figure 12-2.

Trips are listed alphabetically in Table 12-4 based on the trip indication shown on the drive display. Alternatively, the drive status can be read in Pr 10.001 'Drive OK' using communication protocols. The most recent trip can be read in Pr 10.020 providing a trip number. It must be noted that the hardware trips (HF01 to HF20) do not have trip numbers. The trip number must be checked in Table 12-5 to identify the specific trip.

### Example

1. Trip code 2 is read from Pr **10.020** via serial communications.
2. Checking Table 12-4 shows Trip 2 is an Over Volts trip.

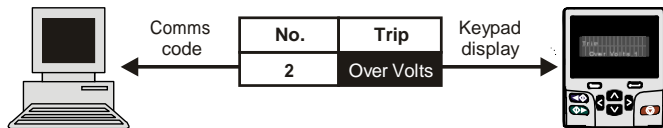

3. Look up Over Volts in Table 12-4.
4. Perform checks detailed under *Diagnosis*.

## 12.3 Identifying a trip / trip source

Some trips only contain a trip string whereas some other trips have a trip string along with a sub-trip number which provides the user with additional information about the trip.

A trip can be generated from a control system or from a power system. The sub-trip number associated with the trips listed in Table 12-2 is in the form *xyzz* and used to identify the source of the trip.

**Table 12-2 Trips associated with *xyzz* sub-trip number**

Over Volts	OHT dc bus
OI ac	Phase Loss
OI Brake	Power Comms
PSU	OI Snubber
OHT Inverter	OHT Rectifier
OHT Power	Temp Feedback
OHT Control	Power Data

The digits *xx* are 00 for a trip generated by the control system. For a single drive (not part of a multi-power module drive), if the trip is related to the power system then *xx* will have a value of 01, when displayed the leading zeros are suppressed.

The *y* digit is used to identify the location of a trip which is generated by a rectifier module connected to a power module (if *xx* is non zero). For a control system trip (*xx* is zero), the *y* digit, where relevant is defined for each trip. If not relevant, the *y* digit will have a value of zero.

The *zz* digits give the reason for the trip and are defined in each trip description.

**Figure 12-4 Key to sub-trip number**

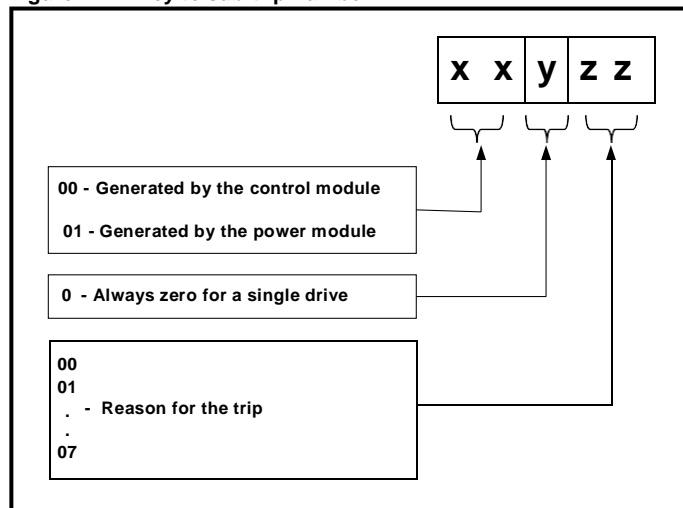

For example, if the drive has tripped and the lower line of the display shows 'OHT Control.2', with the help of Table 12-3 below the trip can be interpreted as; an over temperature has been detected; the trip was generated by fault in the control module, the control board thermistor 2 over temperature. For further information on individual sub-trips, refer to the diagnosis column in Table 12-4 .

**Table 12-3 Sub-trip identification**

Source	xx	y	zz	Description
Control system	00	0	01	Control board thermistor 1 over temperature
Control system	00	0	02	Control board thermistor 2 over temperature
Control system	00	0	03	Control board thermistor 3 over temperature

## 12.4 Trips, Sub-trip numbers

Table 12-4 Trip indications

Trip	Diagnosis								
<b>An Input 1 Loss</b>	<b>Analog input 1 current loss (Unidrive HS70 / HS71)</b>								
28	<p><i>An Input 1 Loss</i> trip indicates that a current loss was detected in current mode on Analog input 1 (Terminal 5, 6). In 4-20 mA and 20-4 mA modes loss of input is detected if the current falls below 3 mA.</p> <p><b>Recommended actions:</b></p> <ul style="list-style-type: none"> <li>• Check control wiring is correct</li> <li>• Check control wiring is undamaged</li> <li>• Check the <i>Analog Input 1 Mode (07.007)</i></li> <li>• Current signal is present and greater than 3 mA</li> </ul>								
<b>An Input 2 Loss</b>	<b>Analog input 2 current loss (Unidrive HS70 / HS71)</b>								
29	<p><i>An Input 2 Loss</i> indicates that a current loss was detected in current mode on Analog input 2 (Terminal 7). In 4-20 mA and 20-4 mA modes loss of input is detected if the current falls below 3 mA.</p> <p><b>Recommended actions:</b></p> <ul style="list-style-type: none"> <li>• Check control wiring is correct</li> <li>• Check control wiring is undamaged</li> <li>• Check the <i>Analog Input 2 Mode (07.011)</i></li> <li>• Current signal is present and greater than 3 mA</li> </ul>								
<b>An Output Calib</b>	<b>Analog output calibration failed (Unidrive HS70 / HS71)</b>								
219	<p>The <i>An output Calib</i> trip indicates that one or both of the Analog outputs have failed during the zero offset calibration. The failed output can be identified by the sub-trip number.</p> <table border="1"> <thead> <tr> <th>Sub-trip</th> <th>Reason</th> </tr> </thead> <tbody> <tr> <td>1</td> <td>Output 1 failed (Terminal 9)</td> </tr> <tr> <td>2</td> <td>Output 2 failed (Terminal 10)</td> </tr> </tbody> </table> <p><b>Recommended actions:</b></p> <ul style="list-style-type: none"> <li>• Check the wiring associated with analog outputs</li> <li>• Remove all the wiring that is connected to analog outputs and perform the calibration</li> <li>• If trip persists replace the drive</li> </ul>	Sub-trip	Reason	1	Output 1 failed (Terminal 9)	2	Output 2 failed (Terminal 10)		
Sub-trip	Reason								
1	Output 1 failed (Terminal 9)								
2	Output 2 failed (Terminal 10)								
<b>App Menu Changed</b>	<b>Customization table for an application module has changed</b>								
217	<p>The <i>App Menu Changed</i> trip indicates that the customization table for an application menu has changed. The menu that has been changed can be identified by the sub-trip number.</p> <table border="1"> <thead> <tr> <th>Sub-trip</th> <th>Reason</th> </tr> </thead> <tbody> <tr> <td>1</td> <td>Menu 18</td> </tr> <tr> <td>2</td> <td>Menu 19</td> </tr> <tr> <td>3</td> <td>Menu 20</td> </tr> </tbody> </table> <p><b>Recommended actions:</b></p> <ul style="list-style-type: none"> <li>• Reset the trip and perform a parameter save to accept the new settings</li> </ul>	Sub-trip	Reason	1	Menu 18	2	Menu 19	3	Menu 20
Sub-trip	Reason								
1	Menu 18								
2	Menu 19								
3	Menu 20								
<b>Autotune 1</b>	<b>Position feedback did not change or required speed could not be reached</b>								
11	<p>The drive has tripped during an autotune. The cause of the trip can be identified from the sub-trip number.</p> <table border="1"> <thead> <tr> <th>Sub-trip</th> <th>Reason</th> </tr> </thead> <tbody> <tr> <td>1</td> <td>The position feedback did not change when position feedback is being used during rotating autotune.</td> </tr> <tr> <td>2</td> <td>The motor did not reach the required speed during rotating autotune or mechanical load measurement.</td> </tr> </tbody> </table> <p><b>Recommended actions:</b></p> <ul style="list-style-type: none"> <li>• Ensure the motor is free to turn i.e. mechanical brake was released</li> <li>• Ensure Pr <b>03.026</b> and Pr <b>03.038</b> are set correctly (or appropriate 2<sup>nd</sup> motor map parameters)</li> <li>• Check feedback device wiring is correct</li> <li>• Check encoder mechanical coupling to the motor</li> </ul>	Sub-trip	Reason	1	The position feedback did not change when position feedback is being used during rotating autotune.	2	The motor did not reach the required speed during rotating autotune or mechanical load measurement.		
Sub-trip	Reason								
1	The position feedback did not change when position feedback is being used during rotating autotune.								
2	The motor did not reach the required speed during rotating autotune or mechanical load measurement.								

Trip	Diagnosis								
<b>Autotune 2</b>	<b>Position feedback direction incorrect</b>								
12	The drive has tripped during a rotating autotune. The cause of the trip can be identified from the associated sub-trip number.								
	<table border="1"> <thead> <tr> <th>Sub-trip</th> <th>Reason</th> </tr> </thead> <tbody> <tr> <td>1</td> <td>The position feedback direction is incorrect when position feedback is being used during a rotating autotune</td> </tr> <tr> <td>2</td> <td>The motor did not reach the required speed during rotating autotune or mechanical load measurement.</td> </tr> </tbody> </table>	Sub-trip	Reason	1	The position feedback direction is incorrect when position feedback is being used during a rotating autotune	2	The motor did not reach the required speed during rotating autotune or mechanical load measurement.		
	Sub-trip	Reason							
	1	The position feedback direction is incorrect when position feedback is being used during a rotating autotune							
2	The motor did not reach the required speed during rotating autotune or mechanical load measurement.								
<b>Recommended actions:</b> <ul style="list-style-type: none"> <li>• Check motor cable wiring is correct</li> <li>• Check feedback device wiring is correct</li> <li>• Swap any two motor phases</li> </ul>									
<b>Autotune 3</b>	<b>Measured inertia has exceeded the parameter range or commutation signals changed in wrong direction</b>								
13	The drive has tripped during a rotating autotune or mechanical load measurement test. The cause of the trip can be identified from the associated sub-trip number.								
	<table border="1"> <thead> <tr> <th>Sub-trip</th> <th>Reason</th> </tr> </thead> <tbody> <tr> <td>1</td> <td>Measured inertia has exceeded the parameter range during a mechanical load measurement</td> </tr> <tr> <td>2</td> <td>The commutation signals changed in the wrong direction during a rotating autotune</td> </tr> <tr> <td>3</td> <td>The mechanical load test has been unable to identify the motor inertia.</td> </tr> </tbody> </table>	Sub-trip	Reason	1	Measured inertia has exceeded the parameter range during a mechanical load measurement	2	The commutation signals changed in the wrong direction during a rotating autotune	3	The mechanical load test has been unable to identify the motor inertia.
	Sub-trip	Reason							
	1	Measured inertia has exceeded the parameter range during a mechanical load measurement							
2	The commutation signals changed in the wrong direction during a rotating autotune								
3	The mechanical load test has been unable to identify the motor inertia.								
<b>Recommended actions:</b> <ul style="list-style-type: none"> <li>• Check motor cable wiring is correct</li> <li>• Check feedback device U,V and W commutation signal wiring is correct</li> </ul>									
<b>Autotune 4</b>	<b>Drive encoder U commutation signal fail</b>								
14	A position feedback device with commutation signals is being used (i.e. AB Servo, FD Servo, FR Servo, SC Servo, or Commutations only encoder) and the U commutation signal did not change during a rotating autotune. <b>Recommended actions:</b> <ul style="list-style-type: none"> <li>• Check feedback device U commutation signal wiring is correct (Encoder terminals 7 and 8)</li> </ul>								
<b>Autotune 5</b>	<b>Drive encoder V commutation signal fail</b>								
15	A position feedback device with commutation signals is being used (i.e. AB Servo, FD Servo, FR Servo, SC Servo, or Commutations only encoder) and the V commutation signal did not change during a rotating autotune. <b>Recommended actions:</b> <ul style="list-style-type: none"> <li>• Check feedback device V commutation signal wiring is correct (Encoder terminals 9 and 10)</li> </ul>								
<b>Autotune 6</b>	<b>Drive encoder W commutation signal fail</b>								
16	A position feedback device with commutation signals is being used (i.e. AB Servo, FD Servo, FR Servo, SC Servo, or Commutations only encoder) and the W commutation signal did not change during a rotating autotune. <b>Recommended actions:</b> <ul style="list-style-type: none"> <li>• Check feedback device W commutation signal wiring is correct (Encoder terminals 11 and 12)</li> </ul>								
<b>Autotune 7</b>	<b>Motor number of poles / position feedback resolution set incorrectly</b>								
17	An <i>Autotune 7</i> trip is initiated during a rotating autotune, if the motor poles or the position feedback resolution have been set up incorrectly where position feedback is being used. <b>Recommended actions:</b> <ul style="list-style-type: none"> <li>• Check line per revolution for feedback device</li> <li>• Check the number of poles in Pr <b>05.011</b></li> </ul>								
<b>Autotune Stopped</b>	<b>Autotune test stopped before completion</b>								
18	The drive was prevented from completing an autotune test, because either the drive enable or the drive run were removed. <b>Recommended actions:</b> <ul style="list-style-type: none"> <li>• Check the drive enable signal (terminal 31 on <i>Unidrive HS70 / HS71</i> and terminal 11 &amp; 13 on <i>Unidrive HS72</i>) was active during the autotune</li> <li>• Check the run command was active in Pr <b>08.005</b> during autotune</li> </ul>								
<b>Brake R Too Hot</b>	<b>Braking resistor overload timed out (I<sup>2</sup>t)</b>								
19	The <i>Brake R Too Hot</i> indicates that braking resistor overload has timed out. The value in <i>Braking Resistor Thermal Accumulator</i> (10.039) is calculated using <i>Braking Resistor Rated Power</i> (10.030), <i>Braking Resistor Thermal Time Constant</i> (10.031) and <i>Braking Resistor Resistance</i> (10.061). The <i>Brake R Too Hot</i> trip is initiated when <i>Braking Resistor Thermal Accumulator</i> (10.039) reaches 100 %. <b>Recommended actions:</b> <ul style="list-style-type: none"> <li>• Ensure the values entered in Pr <b>10.030</b>, Pr <b>10.031</b> and Pr <b>10.061</b> are correct</li> <li>• If an external thermal protection device is being used and the braking resistor software overload protection is not required, set Pr <b>10.030</b>, Pr <b>10.031</b> or Pr <b>10.061</b> to 0 to disable the trip.</li> </ul>								

Trip	Diagnosis						
<b>CAM</b>	<b>Advanced motion controller CAM failure</b>						
99	The <i>CAM</i> trip indicates that the advanced motion controller CAM has detected a problem.						
	<table border="1"> <thead> <tr> <th>Sub-trip</th> <th>Reason</th> </tr> </thead> <tbody> <tr> <td>1</td> <td>CAM index or segment is out of range</td> </tr> <tr> <td>2</td> <td><i>AMC CAM Index</i> (35.007) has been made to change by more than 2 in one sample</td> </tr> </tbody> </table>	Sub-trip	Reason	1	CAM index or segment is out of range	2	<i>AMC CAM Index</i> (35.007) has been made to change by more than 2 in one sample
	Sub-trip	Reason					
1	CAM index or segment is out of range						
2	<i>AMC CAM Index</i> (35.007) has been made to change by more than 2 in one sample						
<b>Card Access</b>	<b>NV Media Card Write fail</b>						
185	The <i>Card Access</i> trip indicates that the drive was unable to access the NV Media Card. If the trip occurs during the data transfer to the card then the file being written may be corrupted. If the trip occurs when the data being transferred to the drive then the data transfer may be incomplete. If a parameter file is transferred to the drive and this trip occurs during the transfer, the parameters are not saved to non-volatile memory, and so the original parameters can be restored by powering the drive down and up again.						
	<p><b>Recommended actions:</b></p> <ul style="list-style-type: none"> <li>• Check NV Media Card is installed / located correctly</li> <li>• Replace the NV Media Card</li> </ul>						
<b>Card Boot</b>	<b>The Menu 0 parameter modification cannot be saved to the NV Media Card</b>						
177	Menu 0 changes are automatically saved on exiting edit mode.						
	The <i>Card Boot</i> trip will occur if a write to a Menu 0 parameter has been initiated via the keypad by exiting edit mode and Pr <b>11.042</b> is set for auto or boot mode, but the necessary boot file has not been created on the NV Media Card to take the new parameter value. This occurs when Pr <b>11.042</b> is changed to Auto (3) or Boot (4) mode, but the drive is not subsequently reset.						
	<p><b>Recommended actions:</b></p> <ul style="list-style-type: none"> <li>• Ensure that Pr <b>11.042</b> is correctly set, and then reset the drive to create the necessary file on the NV Media Card</li> <li>• Re-attempt the parameter write to the Menu 0 parameter</li> </ul>						
<b>Card Busy</b>	<b>NV Media Card cannot be accessed as it is being accessed by an option module</b>						
178	The <i>Card Busy</i> trip indicates that an attempt has been made to access a file on NV Media Card, but the NV Media Card is already being accessed by an Option Module, such as one of the Applications modules. No data is transferred.						
	<p><b>Recommended actions:</b></p> <ul style="list-style-type: none"> <li>• Wait for the option module to finish accessing the NV Media Card and re-attempt the required function</li> </ul>						
<b>Card Data Exists</b>	<b>NV Media Card data location already contains data</b>						
179	The <i>Card Data Exists</i> trip indicates that an attempt has been made to store data on a NV Media Card in a data block which already contains data.						
	<p><b>Recommended actions:</b></p> <ul style="list-style-type: none"> <li>• Erase the data in data location</li> <li>• Write data to an alternative data location</li> </ul>						
<b>Card Compare</b>	<b>NV Media Card file/data is different to the one in the drive</b>						
188	A compare has been carried out between a file on the NV Media Card, a Card Compare trip is initiated if the parameters on the NV Media Card are different to the drive.						
	<p><b>Recommended actions:</b></p> <ul style="list-style-type: none"> <li>• Set Pr <b>mm.000</b> to 0 and reset the trip</li> <li>• Check to ensure the correct data block on the</li> <li>• NV Media Card has been used for the compare</li> </ul>						
<b>Card Drive Mode</b>	<b>NV Media Card parameter set not compatible with current drive mode</b>						
187	The <i>Card Drive Mode</i> trip is produced during a compare if the drive mode in the data block on the NV Media Card is different from the current drive mode. This trip is also produced if an attempt is made to transfer parameters from a NV Media Card to the drive if the operating mode in the data block is outside the allowed range of operating modes.						
	<p><b>Recommended actions:</b></p> <ul style="list-style-type: none"> <li>• Ensure the destination drive supports the drive operating mode in the parameter file.</li> <li>• Clear the value in Pr <b>mm.000</b> and reset the drive</li> <li>• Ensure destination drive operating mode is the same as the source parameter file</li> </ul>						

Trip	Diagnosis								
<b>Card Error</b>	<b>NV Media Card data structure error</b>								
182	The <i>Card Error</i> trip indicates that an attempt has been made to access a NV Media Card but an error has been detected in the data structure on the card. Resetting the trip will cause the drive to erase and create the correct folder structure. The cause of the trip can be identified by the sub-trip.								
	<table border="1"> <thead> <tr> <th>Sub-trip</th> <th>Reason</th> </tr> </thead> <tbody> <tr> <td>1</td> <td>The required folder and file structure is not present</td> </tr> <tr> <td>2</td> <td>The HEADER.DAT file is corrupted</td> </tr> <tr> <td>3</td> <td>Two or more files in the GT8DATA\DRIVE folder have the same file identification number</td> </tr> </tbody> </table>	Sub-trip	Reason	1	The required folder and file structure is not present	2	The HEADER.DAT file is corrupted	3	Two or more files in the GT8DATA\DRIVE folder have the same file identification number
	Sub-trip	Reason							
	1	The required folder and file structure is not present							
	2	The HEADER.DAT file is corrupted							
3	Two or more files in the GT8DATA\DRIVE folder have the same file identification number								
<b>Recommended actions:</b>									
<ul style="list-style-type: none"> <li>Erase all the data block and re-attempt the process</li> <li>Ensure the card is located correctly</li> <li>Replace the NV Media Card</li> </ul>									
<b>Card Full</b>	<b>NV Media Card full</b>								
184	The <i>Card Full</i> trip indicates that an attempt has been made to create a data block on a NV Media Card, but there is not enough space left on the card.								
	<b>Recommended actions:</b> <ul style="list-style-type: none"> <li>Delete a data block or the entire NV Media Card to create space</li> <li>Use a different NV Media Card</li> </ul>								
<b>Card No Data</b>	<b>NV Media Card data not found</b>								
183	The <i>Card No Data</i> trip indicates that an attempt has been made to access non-existent file or block on a NV Media Card.								
	<b>Recommended actions:</b> <ul style="list-style-type: none"> <li>Ensure data block number is correct</li> </ul>								
<b>Card Option</b>	<b>NV Media Card trip; option modules installed are different between source drive and destination drive</b>								
180	The <i>Card Option</i> trip indicates that parameter data or default difference data is being transferred from a NV Media Card to the drive, but the option module categories are different between source and destination drives. This trip does not stop the data transfer, but is a warning that the data for the option modules that are different will be set to the default values and not the values from the card. This trip also applies if a compare is attempted between the data block and the drive.								
	<b>Recommended actions:</b> <ul style="list-style-type: none"> <li>Ensure the correct option modules are installed.</li> <li>Ensure the option modules are in the same option module slot as the parameter set stored.</li> <li>Press the red reset button to acknowledge that the parameters for one or more of the option modules installed will be at their default values</li> <li>This trip can be suppressed by setting Pr <b>mm.000</b> to 9666 and resetting the drive.</li> </ul>								
<b>Card Product</b>	<b>NV Media Card data blocks are not compatible with the drive derivative</b>								
175	The <i>Card Product</i> trip is initiated either at power-up or when the card is accessed, if <i>Drive Derivative</i> (11.028) is different between the source and target drives. This trip can be reset and data can be transferred in either direction between the drive and the card.								
	<b>Recommended actions:</b> <ul style="list-style-type: none"> <li>Use a different NV Media Card</li> <li>This trip can be suppressed by setting Pr <b>mm.000</b> to 9666 and resetting the drive</li> </ul>								
<b>Card Rating</b>	<b>NV Media Card Trip; The voltage and / or current rating of the source and destination drives are different</b>								
186	The Card Rating trip indicates that parameter data is being transferred from a NV Media Card to the drive, but the current and / or voltage ratings are different between source and destination drives. This trip also applies if a compare (using Pr <b>mm.000</b> set to 8yyy) is attempted between the data block on a NV Media Card and the drive. The Card Rating trip does not stop the data transfer but is a warning that rating specific parameters with the RA attribute may not be transferred to the destination drive.								
	<b>Recommended actions:</b> <ul style="list-style-type: none"> <li>Reset the drive to clear the trip</li> <li>Ensure that the drive rating dependent parameters have transferred correctly</li> </ul>								
<b>Card Read Only</b>	<b>NV Media Card has the Read Only bit set</b>								
181	The <i>Card Read Only</i> trip indicates that an attempt has been made to modify a read-only NV Media Card or a read-only data block. A NV Media Card is read-only if the read-only flag has been set.								
	<b>Recommended actions:</b> <ul style="list-style-type: none"> <li>Clear the read only flag by setting Pr <b>mm.000</b> to 9777 and reset the drive. This will clear the read-only flag for all data blocks in the NV Media Card</li> </ul>								

Trip	Diagnosis
<b>Card Slot</b>	<b>NV Media Card Trip; Option module application program transfer has failed</b>
174	<p>The <i>Card Slot</i> trip is initiated, if the transfer of an option module application program to or from an application module failed because the option module does not respond correctly. If this happens this trip is produced with the sub-trip indicating the option module slot number.</p> <p><b>Recommended actions:</b></p> <ul style="list-style-type: none"> <li>• Ensure the source / destination option module is installed on the correct slot</li> </ul>
<b>Configuration</b>	<b>The number of power modules installed is different from the modules expected</b>
111	<p>The <i>Configuration</i> trip indicates that the <i>Number Of Power Modules Detected</i> (11.071) does not match the previous value stored.</p> <p><b>Recommended actions:</b></p> <ul style="list-style-type: none"> <li>• Ensure that all the power modules are correctly connected / simultaneously</li> <li>• Ensure all the power modules have powered up correctly</li> <li>• Ensure that the value in Pr <b>11.071</b> is set to the number of power modules connected</li> <li>• Set Pr <b>11.035</b> to 0 to disable the trip if it is not required</li> </ul>
<b>Control Word</b>	<b>Trip initiated from the Control Word (06.042)</b>
35	<p>The Control Word trip is initiated by setting bit 12 on the control word in Pr <b>06.042</b> when the control word is enabled (Pr <b>06.043</b> = On).</p> <p><b>Recommended actions:</b></p> <ul style="list-style-type: none"> <li>• Check the value of Pr <b>06.042</b>.</li> <li>• Disable the control word in <i>Control Word Enable</i> (Pr <b>06.043</b>) <ul style="list-style-type: none"> <li>Bit 12 of the control word set to a one causes the drive to trip on Control Word</li> <li>When the control word is enabled, the trip can only be cleared by setting bit 12 to zero</li> </ul> </li> </ul>
<b>Current Offset</b>	<b>Current feedback offset error</b>
225	<p>The <i>Current Offset</i> trip indicates that the current offset is too larger to be trimmed.</p> <p><b>Recommended actions:</b></p> <ul style="list-style-type: none"> <li>• Ensure that there is no possibility of current flowing in the output phases of the drive when the drive is not enabled</li> <li>• Hardware fault – Contact the supplier of the drive</li> </ul>
<b>Data Changing</b>	<b>Drive parameters are being changed</b>
97	<p>A user action or a file system write is active that is changing the drive parameters and the drive has been commanded to enable, i.e. <i>Drive Active</i> (10.002) = 1.</p> <p><b>Recommended actions:</b></p> <ul style="list-style-type: none"> <li>• Ensure the drive is not enabled when one of the following is being carried out <ul style="list-style-type: none"> <li>Loading defaults</li> <li>Changing drive mode</li> <li>Transferring data from NV Media Card or position feedback device</li> <li>Transferring user programs</li> </ul> </li> </ul>
<b>Derivative ID</b>	<b>Derivative identification error</b>
247	<p>The derivative image which customizes the drive has been changed for an image with a different identifier.</p> <p><b>Recommended actions:</b></p> <ul style="list-style-type: none"> <li>• Contact the supplier of the drive</li> </ul>
<b>Derivative Image</b>	<b>Derivative Image error</b>
248	<p>The <i>Derivative Image</i> trip indicates that an error has been detected in the derivative image.</p> <p><b>Recommended action:</b></p> <ul style="list-style-type: none"> <li>• Contact the supplier of the drive</li> </ul>
<b>Destination</b>	<b>Two or more parameters are writing to the same destination parameter</b>
199	<p>The Destination trip indicates that destination output parameters of two or more logic functions (Menus 3, 7, 8, 9, 12 or 14) within the drive are writing to the same parameter.</p> <p><b>Recommended actions:</b></p> <ul style="list-style-type: none"> <li>• Set Pr <b>mm.000</b> to 'Destinations' or 12001 and check all visible parameters in all menus for parameter write conflicts</li> </ul>
<b>Drive Size</b>	<b>Power stage recognition: Unrecognized drive size</b>
224	<p>The <i>Drive Size</i> trip indicates that the control PCB has not recognized the drive size of the power circuit to which it is connected.</p> <p><b>Recommended action:</b></p> <ul style="list-style-type: none"> <li>• Ensure the drive is programmed to the latest firmware version</li> <li>• Hardware fault - return drive to supplier</li> </ul>

Trip	Diagnosis																				
<b>EEPROM Fail</b>	<b>Default parameters have been loaded</b>																				
31	The <i>EEPROM Fail</i> trip indicates that default parameters have been loaded. The exact cause/reason of the trip can be identified from the sub-trip number.																				
	<table border="1"> <thead> <tr> <th>Sub-trip</th> <th>Reason</th> </tr> </thead> <tbody> <tr> <td>1</td> <td>The most significant digit of the internal parameter database version number has changed</td> </tr> <tr> <td>2</td> <td>The CRCs applied to the parameter data stored in internal non-volatile memory indicate that a valid set of parameters cannot be loaded</td> </tr> <tr> <td>3</td> <td>The drive mode restored from internal non-volatile memory is outside the allowed range for the product or the derivative image does not allow the previous drive mode</td> </tr> <tr> <td>4</td> <td>The drive derivative image has changed</td> </tr> <tr> <td>5</td> <td>The power stage hardware has changed</td> </tr> <tr> <td>6</td> <td>The internal I/O hardware has changed</td> </tr> <tr> <td>7</td> <td>The position feedback interface hardware has changed</td> </tr> <tr> <td>8</td> <td>The control board hardware has changed</td> </tr> <tr> <td>9</td> <td>The checksum on the non-parameter area of the EEPROM has failed</td> </tr> </tbody> </table>	Sub-trip	Reason	1	The most significant digit of the internal parameter database version number has changed	2	The CRCs applied to the parameter data stored in internal non-volatile memory indicate that a valid set of parameters cannot be loaded	3	The drive mode restored from internal non-volatile memory is outside the allowed range for the product or the derivative image does not allow the previous drive mode	4	The drive derivative image has changed	5	The power stage hardware has changed	6	The internal I/O hardware has changed	7	The position feedback interface hardware has changed	8	The control board hardware has changed	9	The checksum on the non-parameter area of the EEPROM has failed
	Sub-trip	Reason																			
	1	The most significant digit of the internal parameter database version number has changed																			
	2	The CRCs applied to the parameter data stored in internal non-volatile memory indicate that a valid set of parameters cannot be loaded																			
	3	The drive mode restored from internal non-volatile memory is outside the allowed range for the product or the derivative image does not allow the previous drive mode																			
	4	The drive derivative image has changed																			
	5	The power stage hardware has changed																			
	6	The internal I/O hardware has changed																			
	7	The position feedback interface hardware has changed																			
8	The control board hardware has changed																				
9	The checksum on the non-parameter area of the EEPROM has failed																				
<b>Recommended actions:</b>																					
<ul style="list-style-type: none"> <li>• Default the drive and perform a reset</li> <li>• Allow sufficient time to perform a save before the supply to the drive is removed</li> <li>• If the trip persists - return drive to supplier</li> </ul>																					
<b>Encoder 1</b>	<b>Drive position feedback interface power supply overload</b>																				
189	The <i>Encoder 1</i> trip indicates that the drive encoder power supply has been overloaded. Terminals 13 & 14 of the 15 way D type connector can supply a maximum current of 200 mA @ 15 V or 300 mA @ 8 V and 5 V.																				
	<b>Recommended actions:</b> <ul style="list-style-type: none"> <li>• Check encoder power supply wiring</li> <li>• Disable the termination resistors (Pr <b>03.039</b> set to 0) to reduce current consumption</li> <li>• For 5 V encoders with long cables, select 8 V (Pr <b>03.036</b>) and install a 5 V voltage regulator close to the encoder</li> <li>• Check the encoder specification to confirm if it is compatible with the encoder port power supply current capability</li> <li>• Replace the encoder</li> <li>• Use an external power supply with higher current capability</li> </ul>																				
<b>Encoder 2</b>	<b>Drive encoder (Feedback) wire break</b>																				
190	The <i>Encoder 2</i> trip indicates that the drive has detected a wire break on the 15 way D-type connector on the drive. The exact cause of the trip can be identified from the sub-trip number.																				
	<table border="1"> <thead> <tr> <th>Sub-trip</th> <th>Reason</th> </tr> </thead> <tbody> <tr> <td>10</td> <td>Drive position feedback interface 1 on any input</td> </tr> <tr> <td>20</td> <td>Drive position feedback interface 2 on any input</td> </tr> <tr> <td>11</td> <td>Drive position feedback interface 1 on the A channel</td> </tr> <tr> <td>12</td> <td>Drive position feedback interface 1 on the B channel</td> </tr> <tr> <td>13</td> <td>Drive position feedback interface 1 on the Z channel</td> </tr> </tbody> </table>	Sub-trip	Reason	10	Drive position feedback interface 1 on any input	20	Drive position feedback interface 2 on any input	11	Drive position feedback interface 1 on the A channel	12	Drive position feedback interface 1 on the B channel	13	Drive position feedback interface 1 on the Z channel								
	Sub-trip	Reason																			
	10	Drive position feedback interface 1 on any input																			
	20	Drive position feedback interface 2 on any input																			
	11	Drive position feedback interface 1 on the A channel																			
12	Drive position feedback interface 1 on the B channel																				
13	Drive position feedback interface 1 on the Z channel																				
<b>Recommended actions:</b>																					
<ul style="list-style-type: none"> <li>• If wire break detection on the drive encoder input is not required, set Pr <b>03.040</b> = XXX0 to disable the Encoder 2 trip</li> <li>• Check cable continuity</li> <li>• Check wiring of feedback signals is correct</li> <li>• Check encoder power supply is set correctly (Pr <b>03.036</b>)</li> <li>• Replace encoder</li> </ul>																					

Trip	Diagnosis						
<b>Encoder 3</b>	<b>Phase offset incorrect while running</b>						
191	The <i>Encoder 3</i> trip indicates that the drive has detected an incorrect UVW phase angle while running (RFC-S mode only) or SINCOS phase error. The feedback device which has caused the trip can be identified by the sub-trip number.						
	<table border="1"> <thead> <tr> <th>Sub-trip</th> <th>Reason</th> </tr> </thead> <tbody> <tr> <td>1</td> <td>Drive position feedback interface 1</td> </tr> <tr> <td>2</td> <td>Drive position feedback interface 2</td> </tr> </tbody> </table>	Sub-trip	Reason	1	Drive position feedback interface 1	2	Drive position feedback interface 2
	Sub-trip	Reason					
1	Drive position feedback interface 1						
2	Drive position feedback interface 2						
<p><b>Recommended actions:</b></p> <ul style="list-style-type: none"> <li>• Check encoder shield connections</li> <li>• Ensure the encoder cable is one uninterrupted cable</li> <li>• Check the encoder signal for noise with an oscilloscope</li> <li>• Check the integrity of the encoder mechanical mounting</li> <li>• For a UVW servo encoder, ensure that the phase rotation of the UVW commutation signals is the same as the phase rotation of the motor</li> <li>• For a SINCOS encoder, ensure that motor and incremental SINCOS connections are correct and that for forward rotation of the motor, the encoder rotates clockwise (when looking at the shaft of the encoder)</li> <li>• Repeat the offset measurement test</li> </ul>							
<b>Encoder 4</b>	<b>Feedback device comms failure</b>						
192	The Encoder 4 trip indicates that the encoder communications has timed out or the communications position message transfer time is too long. This trip can also be caused due to wire break in the communication channel between the drive and the encoder. The feedback device which has caused the trip can be identified by the sub-trip number.						
	<table border="1"> <thead> <tr> <th>Sub-trip</th> <th>Reason</th> </tr> </thead> <tbody> <tr> <td>1</td> <td>Drive position feedback interface 1</td> </tr> <tr> <td>2</td> <td>Drive position feedback interface 2</td> </tr> </tbody> </table>	Sub-trip	Reason	1	Drive position feedback interface 1	2	Drive position feedback interface 2
	Sub-trip	Reason					
1	Drive position feedback interface 1						
2	Drive position feedback interface 2						
<p><b>Recommended actions:</b></p> <ul style="list-style-type: none"> <li>• Ensure the encoder power supply setting (Pr <b>03.036</b>) is correct</li> <li>• Complete encoder auto-configuration (Pr <b>03.041</b>)</li> <li>• Check the encoder wiring</li> <li>• Replace the feedback device</li> </ul>							
<b>Encoder 5</b>	<b>Checksum or CRC error</b>						
193	The <i>Encoder 5</i> trip indicates that there is a checksum or CRC error, or the SSI encoder is not ready. The Encoder 5 trip can also indicate a wire break to a communications based encoder.						
	<table border="1"> <thead> <tr> <th>Sub-trip</th> <th>Reason</th> </tr> </thead> <tbody> <tr> <td>1</td> <td>Drive position feedback interface 1</td> </tr> <tr> <td>2</td> <td>Drive position feedback interface 2</td> </tr> </tbody> </table>	Sub-trip	Reason	1	Drive position feedback interface 1	2	Drive position feedback interface 2
	Sub-trip	Reason					
1	Drive position feedback interface 1						
2	Drive position feedback interface 2						
<p><b>Recommended actions:</b></p> <ul style="list-style-type: none"> <li>• Check the encoder cable shield connections</li> <li>• Ensure the cable is one uninterrupted cable - remove any connector blocks or if unavoidable minimise the length of any shield pigtailed to the connector block</li> <li>• Check the encoder signal for noise with an oscilloscope</li> <li>• Check the comms resolution setting (Pr <b>03.035</b>)</li> <li>• If using a Hiperface, EnDat encoder or BiSS encoder carry out an encoder auto-configuration (Pr <b>03.041</b> = Enabled)</li> <li>• Replace the encoder</li> </ul>							
<b>Encoder 6</b>	<b>Encoder has indicated an error</b>						
194	The <i>Encoder 6</i> trip indicates that the encoder has indicated an error or that the power supply has failed to an SSI encoder. The <i>Encoder 6</i> trip can also indicate a wire break to an SSI encoder.						
	<table border="1"> <thead> <tr> <th>Sub-trip</th> <th>Reason</th> </tr> </thead> <tbody> <tr> <td>1</td> <td>Drive position feedback interface 1</td> </tr> <tr> <td>2</td> <td>Drive position feedback interface 2</td> </tr> </tbody> </table>	Sub-trip	Reason	1	Drive position feedback interface 1	2	Drive position feedback interface 2
	Sub-trip	Reason					
1	Drive position feedback interface 1						
2	Drive position feedback interface 2						
<p><b>Recommended actions:</b></p> <ul style="list-style-type: none"> <li>• For SSI encoders, check the wiring and encoder power supply setting (Pr <b>03.036</b>)</li> <li>• Replace the encoder / contact the supplier of the encoder</li> </ul>							

Trip	Diagnosis		
<b>Encoder 7</b>	<b>Initialization failed</b>		
195	The <i>Encoder 7</i> trip indicates that the set-up parameters for position feedback device has changed. The feedback device which has caused the trip can be identified by the sub-trip number.		
	<b>Sub-trip</b>	<b>Reason</b>	
	1	Drive position feedback interface 1	
	2	Drive position feedback interface 2	
<b>Recommended actions:</b> <ul style="list-style-type: none"> <li>Reset the trip and perform a save.</li> <li>Ensure Pr <b>3.033</b> and Pr <b>03.035</b> are set correctly or carry out an encoder auto-configuration (Pr <b>03.041</b> = Enabled)</li> </ul>			
<b>Encoder 8</b>	<b>Position feedback interface has timed out</b>		
196	The <i>Encoder 8</i> trip indicates that Position feedback interface communications time exceeds 250 $\mu$ s. The feedback device which has caused the trip can be identified by the sub-trip number.		
	<b>Sub-trip</b>	<b>Reason</b>	
	1	Drive position feedback interface 1	
	2	Drive position feedback interface 2	
<b>Recommended actions:</b> <ul style="list-style-type: none"> <li>Ensure the encoder is connected correctly</li> <li>Ensure that the encoder is compatible</li> <li>Increase baud rate</li> </ul>			
<b>Encoder 9</b>	<b>Position feedback is selected from a option module slot which does not have a feedback option module installed</b>		
197	The <i>Encoder 9</i> trip indicates that position feedback source selected in Pr <b>03.026</b> (or Pr <b>21.021</b> for the second motor map) is not valid		
	<b>Recommended actions:</b> <ul style="list-style-type: none"> <li>Check the setting of Pr <b>03.026</b> (or Pr <b>21.021</b> if the second motor parameters have been enabled)</li> <li>Ensure that the option slot selected in Pr <b>03.026</b> has a feedback option module installed</li> </ul>		
<b>Encoder 12</b>	<b>Encoder could not be identified during auto-configuration</b>		
162	The <i>Encoder 12</i> trip indicates that the drive is communicating with the encoder but the encoder type is not recognized.		
	<b>Sub-trip</b>	<b>Reason</b>	
	1	Drive position feedback interface 1	
	2	Drive position feedback interface 2	
<b>Recommended actions:</b> <ul style="list-style-type: none"> <li>Enter the encoder setup parameters manually</li> <li>Check to see the encoder supports auto-configuration</li> </ul>			
<b>Encoder 13</b>	<b>Data read from the encoder is out of range during auto-configuration</b>		
163	The <i>Encoder 13</i> trip indicates that the data read from the encoder was out of the range during auto-configuration. No parameters will be modified with the data read from the encoder as a result of auto configuration.		
	<b>Sub-trip</b>	<b>Reason</b>	<b>Parameter</b>
	11	P1 Rotary lines per revolution error	<b>03.034</b>
	12	P1 Linear comms pitch error	<b>03.052</b>
	13	P1 Linear line pitch error	<b>03.053</b>
	14	P1 Rotary turns bits error	<b>03.033</b>
	15	P1 Communications bits error	<b>03.035</b>
	16	P1 Calculation time is too long	<b>03.060</b>
	17	P1 Line delay measured is longer than 5 $\mu$ s	<b>03.062</b>
	21	P2 Rotary lines per revolution error	<b>03.134</b>
	22	P2 Linear comms pitch error	<b>03.152</b>
	23	P2 Linear line pitch error	<b>03.153</b>
	24	P2 Rotary turns bits error	<b>03.133</b>
	25	P2 Communications bits error	<b>03.135</b>
26	P2 Calculation time is too long	<b>03.160</b>	
27	P2 Line delay measured is longer than 5 $\mu$ s	<b>03.162</b>	
<b>Recommended actions:</b> <ul style="list-style-type: none"> <li>Enter the encoder setup parameters manually</li> <li>Check to see the encoder supports auto-configuration</li> </ul>			

Trip	Diagnosis								
<b>External Trip</b>	<b>An External trip is initiated</b>								
	An <i>External Trip</i> has occurred. The cause of the trip can be identified from the sub trip number displayed after the trip string. See table below. An external trip can also be initiated by writing a value of 6 in Pr <b>10.038</b> .								
	<table border="1"> <thead> <tr> <th>Sub-trip</th> <th>Reason</th> </tr> </thead> <tbody> <tr> <td>1</td> <td><i>External Trip Mode</i> (08.010) = 1 or 3 and SAFE TORQUE OFF input 1 is low</td> </tr> <tr> <td>2</td> <td><i>External Trip Mode</i> (08.010) = 2 or 3 and SAFE TORQUE OFF input 2 is low</td> </tr> <tr> <td>3</td> <td><i>External Trip</i> (10.032) = 1</td> </tr> </tbody> </table>	Sub-trip	Reason	1	<i>External Trip Mode</i> (08.010) = 1 or 3 and SAFE TORQUE OFF input 1 is low	2	<i>External Trip Mode</i> (08.010) = 2 or 3 and SAFE TORQUE OFF input 2 is low	3	<i>External Trip</i> (10.032) = 1
Sub-trip	Reason								
1	<i>External Trip Mode</i> (08.010) = 1 or 3 and SAFE TORQUE OFF input 1 is low								
2	<i>External Trip Mode</i> (08.010) = 2 or 3 and SAFE TORQUE OFF input 2 is low								
3	<i>External Trip</i> (10.032) = 1								
6	<p><b>Recommended actions:</b></p> <ul style="list-style-type: none"> <li>Check the SAFE TORQUE OFF signal voltage (on terminal 31 on <i>Unidrive HS70 / HS71</i> and terminal 11 &amp; 13 on <i>Unidrive HS72</i>) equals to 24 V.</li> <li>Check the value of Pr <b>08.009</b> which indicates the digital state of terminal 31 on <i>Unidrive HS70 / HS71</i> and terminal 11 &amp; 13 on <i>Unidrive HS72</i>, equates to 'on'.</li> <li>If external trip detection of the SAFE TORQUE OFF input is not required, set Pr <b>08.010</b> to OFF (0).</li> <li>Check the value of Pr <b>10.032</b>.</li> <li>Select 'Destinations' (or enter 12001) in Pr <b>mm.000</b> and check for a parameter controlling Pr <b>10.032</b>.</li> <li>Ensure Pr <b>10.032</b> or Pr <b>10.038</b> (= 6) is not being controlled by serial comms</li> </ul>								
<b>Frequency Range</b>	<b>Out of range of frequency has been detected in regen mode</b>								
168	<p>The <i>Frequency Range</i> trip indicates that the supply frequency is outside the range defined by <i>Regen Minimum Frequency</i> (03.024) and <i>Regen Maximum Frequency</i> (03.025) for more than 100 ms.</p> <p><b>Recommended actions:</b></p> <ul style="list-style-type: none"> <li>Ensure the supply is operating within the drive specification</li> <li>Ensure Pr <b>03.024</b> and Pr <b>03.025</b> are set correctly</li> <li>Check the supply voltage waveform using an oscilloscope</li> <li>Reduce the level of supply disturbance</li> </ul>								
<b>HF01</b>	<b>Data processing error: CPU address error</b>								
	<p>The <i>HF01</i> trip indicates that a CPU address error has occurred. This trip indicates that the control PCB on the drive has failed.</p> <p><b>Recommended actions:</b></p> <ul style="list-style-type: none"> <li>Hardware fault – Contact the supplier of the drive</li> </ul>								
<b>HF02</b>	<b>Data processing error: DMAC address error</b>								
	<p>The <i>HF02</i> trip indicates that a DMAC address error has occurred. This trip indicates that the control PCB on the drive has failed.</p> <p><b>Recommended actions:</b></p> <ul style="list-style-type: none"> <li>Hardware fault – Contact the supplier of the drive</li> </ul>								
<b>HF03</b>	<b>Data processing error: Illegal instruction</b>								
	<p>The <i>HF03</i> trip indicates that an illegal instruction has occurred. This trip indicates that the control PCB on the drive has failed.</p> <p><b>Recommended actions:</b></p> <ul style="list-style-type: none"> <li>Hardware fault – Contact the supplier of the drive</li> </ul>								
<b>HF04</b>	<b>Data processing error: Illegal slot instruction</b>								
	<p>The <i>HF04</i> trip indicates that an illegal slot instruction has occurred. This trip indicates that the control PCB on the drive has failed.</p> <p><b>Recommended actions:</b></p> <ul style="list-style-type: none"> <li>Hardware fault – Contact the supplier of the drive</li> </ul>								
<b>HF05</b>	<b>Data processing error: Undefined exception</b>								
	<p>The <i>HF05</i> trip indicates that an undefined exception error has occurred. This trip indicates that the control PCB on the drive has failed.</p> <p><b>Recommended actions:</b></p> <ul style="list-style-type: none"> <li>Hardware fault – Contact the supplier of the drive</li> </ul>								
<b>HF06</b>	<b>Data processing error: Reserved exception</b>								
	<p>The <i>HF06</i> trip indicates that a reserved exception error has occurred. This trip indicates that the control PCB on the drive has failed.</p> <p><b>Recommended actions:</b></p> <ul style="list-style-type: none"> <li>Hardware fault – Contact the supplier of the drive</li> </ul>								
<b>HF07</b>	<b>Data processing error: Watchdog failure</b>								
	<p>The <i>HF07</i> trip indicates that a watchdog failure has occurred. This trip indicates that the control PCB on the drive has failed.</p> <p><b>Recommended actions:</b></p> <ul style="list-style-type: none"> <li>Hardware fault – Contact the supplier of the drive</li> </ul>								

Trip	Diagnosis								
<b>HF08</b>	<b>Data processing error: CPU Interrupt crash</b>								
	The <i>HF08</i> trip indicates that a CPU interrupt crash has occurred. This trip indicates that the control PCB on the drive has failed. <b>Recommended actions:</b> <ul style="list-style-type: none"> <li>Hardware fault – Contact the supplier of the drive</li> </ul>								
<b>HF09</b>	<b>Data processing error: Free store overflow</b>								
	The <i>HF09</i> trip indicates that a free store overflow has occurred. This trip indicates that the control PCB on the drive has failed. <b>Recommended actions:</b> <ul style="list-style-type: none"> <li>Hardware fault – Contact the supplier of the drive</li> </ul>								
<b>HF10</b>	<b>Data processing error: Parameter routing system error</b>								
	The <i>HF10</i> trip indicates that a Parameter routing system error has occurred. This trip indicates that the control PCB on the drive has failed. <b>Recommended actions:</b> <ul style="list-style-type: none"> <li>Hardware fault – Contact the supplier of the drive</li> </ul>								
<b>HF11</b>	<b>Data processing error: Access to EEPROM failed</b>								
	The <i>HF11</i> trip indicates that access to the drive EEPROM has failed. This trip indicates that the control PCB on the drive has failed. <b>Recommended actions:</b> <ul style="list-style-type: none"> <li>Hardware fault – Contact the supplier of the drive</li> </ul>								
<b>HF12</b>	<b>Data processing error: Main program stack overflow</b>								
	The <i>HF12</i> trip indicates that the main program stack over flow has occurred. The stack can be identified by the sub-trip number. This trip indicates that the control PCB on the drive has failed. <table border="1" data-bbox="354 888 936 1031"> <thead> <tr> <th>Sub-trip</th> <th>Stack</th> </tr> </thead> <tbody> <tr> <td>1</td> <td>Freewheeling tasks</td> </tr> <tr> <td>2</td> <td>Clock tasks</td> </tr> <tr> <td>3</td> <td>Main system interrupts</td> </tr> </tbody> </table> <b>Recommended actions:</b> <ul style="list-style-type: none"> <li>Hardware fault – Contact the supplier of the drive</li> </ul>	Sub-trip	Stack	1	Freewheeling tasks	2	Clock tasks	3	Main system interrupts
Sub-trip	Stack								
1	Freewheeling tasks								
2	Clock tasks								
3	Main system interrupts								
<b>HF13</b>	<b>Data processing error: Firmware incompatible with hardware</b>								
	The <i>HF13</i> trip indicates that the drive firmware is not compatible with the hardware. This trip indicates that the control PCB on the drive has failed. <b>Recommended actions:</b> <ul style="list-style-type: none"> <li>Re-program the drive with the latest version of the drive firmware for <i>Unidrive HS70 / HS71 / HS72</i></li> <li>Hardware fault – Contact the supplier of the drive</li> </ul>								
<b>HF14</b>	<b>Data processing error: CPU register bank error</b>								
	The <i>HF14</i> trip indicates that a CPU register bank error has occurred. This trip indicates that the control PCB on the drive has failed. <b>Recommended actions:</b> <ul style="list-style-type: none"> <li>Hardware fault – Contact the supplier of the drive</li> </ul>								
<b>HF15</b>	<b>Data processing error: CPU divide error</b>								
	The <i>HF15</i> trip indicates that a CPU divide error has occurred. This trip indicates that the control PCB on the drive has failed. <b>Recommended actions:</b> <ul style="list-style-type: none"> <li>Hardware fault – Contact the supplier of the drive</li> </ul>								
<b>HF16</b>	<b>Data processing error: RTOS error</b>								
	The <i>HF16</i> trip indicates that a RTOS error has occurred. This trip indicates that the control PCB on the drive has failed. <b>Recommended actions:</b> <ul style="list-style-type: none"> <li>Hardware fault – Contact the supplier of the drive</li> </ul>								
<b>HF17</b>	<b>Data processing error: Clock supplied to the control board is out of specification</b>								
	The <i>HF17</i> trip indicates that the clock supplied to the control board logic is out of specification. This trip indicates that the control PCB on the drive has failed. <b>Recommended actions:</b> <ul style="list-style-type: none"> <li>Hardware fault – Contact the supplier of the drive</li> </ul>								

Trip	Diagnosis																				
<b>HF18</b>	<b>Data processing error: Internal flash memory has failed</b>																				
	<p>The <i>HF18</i> trip indicates that the internal flash memory has failed when writing option module parameter data. The reason for the trip can be identified by the sub-trip number.</p> <table border="1"> <thead> <tr> <th>Sub-trip</th> <th>Reason</th> </tr> </thead> <tbody> <tr> <td>1</td> <td>Option module initialization timed out</td> </tr> <tr> <td>2</td> <td>Programming error while writing menu in flash</td> </tr> <tr> <td>3</td> <td>Erase flash block containing setup menus failed</td> </tr> <tr> <td>4</td> <td>Erase flash block containing application menus failed</td> </tr> <tr> <td>5</td> <td>Incorrect setup menu CRC contained in flash</td> </tr> <tr> <td>6</td> <td>Incorrect application menu CRC contained in flash</td> </tr> <tr> <td>7</td> <td>Incorrect common application menu 18 CRC contained in flash</td> </tr> <tr> <td>8</td> <td>Incorrect common application menu 19 CRC contained in flash</td> </tr> <tr> <td>9</td> <td>Incorrect common application menu 20 CRC contained in flash</td> </tr> </tbody> </table> <p><b>Recommended actions:</b></p> <ul style="list-style-type: none"> <li>Hardware fault - Contact the supplier of the drive.</li> </ul>	Sub-trip	Reason	1	Option module initialization timed out	2	Programming error while writing menu in flash	3	Erase flash block containing setup menus failed	4	Erase flash block containing application menus failed	5	Incorrect setup menu CRC contained in flash	6	Incorrect application menu CRC contained in flash	7	Incorrect common application menu 18 CRC contained in flash	8	Incorrect common application menu 19 CRC contained in flash	9	Incorrect common application menu 20 CRC contained in flash
Sub-trip	Reason																				
1	Option module initialization timed out																				
2	Programming error while writing menu in flash																				
3	Erase flash block containing setup menus failed																				
4	Erase flash block containing application menus failed																				
5	Incorrect setup menu CRC contained in flash																				
6	Incorrect application menu CRC contained in flash																				
7	Incorrect common application menu 18 CRC contained in flash																				
8	Incorrect common application menu 19 CRC contained in flash																				
9	Incorrect common application menu 20 CRC contained in flash																				
<b>HF19</b>	<b>Data processing error: CRC check on the firmware has failed</b>																				
	<p>The <i>HF19</i> trip indicates that the CRC check on the drive firmware has failed.</p> <p><b>Recommended actions:</b></p> <ul style="list-style-type: none"> <li>Re-program the drive</li> <li>Hardware fault - Contact the supplier of the drive</li> </ul>																				
<b>HF20</b>	<b>Data processing error: ASIC is not compatible with the hardware</b>																				
	<p>The <i>HF20</i> trip indicates that the ASIC version is not compatible with the drive firmware. The ASIC version can be identified from the sub-trip number.</p> <p><b>Recommended actions:</b></p> <ul style="list-style-type: none"> <li>Hardware fault - Contact the supplier of the drive</li> </ul>																				
<b>Inductance</b>	<b>Inductance measurement out of range or motor saturation not detected</b>																				
<b>8</b>	<p>The drive has been enabled in RFC-S mode with <i>RFC Feedback Mode</i> (03.024) set for sensorless control, or for auto-change over on position feedback loss, and the motor inductance will prevent the control algorithm from operating correctly. The reason for the trip can be identified from the sub-trip number.</p> <table border="1"> <thead> <tr> <th>Sub-trip</th> <th>Reason</th> </tr> </thead> <tbody> <tr> <td>1</td> <td> <p>The difference between <i>Ld</i> (05.024) and <i>No-load Lq</i> (05.072) is too small. <math>(Lq-Ld)/Ld</math> must be greater than 0.2. Also <math>Lq-Ld</math> must be greater than <math>K/Full\ Scale\ Current\ Kc</math> (11.061), <math>K</math> is related to the drive voltage rating as given in the table below. It is recommended that the differences are larger than these minimum limits if possible.</p> <table border="1"> <thead> <tr> <th>Drive rated voltage</th> <th>K</th> </tr> </thead> <tbody> <tr> <td>200 V</td> <td>0.037</td> </tr> <tr> <td>400 V</td> <td>0.073</td> </tr> <tr> <td>575 V</td> <td>0.087</td> </tr> <tr> <td>690 V</td> <td>0.105</td> </tr> </tbody> </table> </td> </tr> <tr> <td>2</td> <td>A test is carried out to determine the direction of the flux in the motor which relies on detecting motor saturation. If a change in motor saturation cannot be detected during this test then this trip is initiated. This type of failure is unlikely in most normal motors.</td> </tr> <tr> <td>3</td> <td>During the stationary auto-tuning in RFC-S mode it is necessary to determine the location of the flux axis. If a change in motor saturation cannot be detected during this test then this trip is initiated. This type of failure is unlikely in most normal motors.</td> </tr> </tbody> </table>	Sub-trip	Reason	1	<p>The difference between <i>Ld</i> (05.024) and <i>No-load Lq</i> (05.072) is too small. <math>(Lq-Ld)/Ld</math> must be greater than 0.2. Also <math>Lq-Ld</math> must be greater than <math>K/Full\ Scale\ Current\ Kc</math> (11.061), <math>K</math> is related to the drive voltage rating as given in the table below. It is recommended that the differences are larger than these minimum limits if possible.</p> <table border="1"> <thead> <tr> <th>Drive rated voltage</th> <th>K</th> </tr> </thead> <tbody> <tr> <td>200 V</td> <td>0.037</td> </tr> <tr> <td>400 V</td> <td>0.073</td> </tr> <tr> <td>575 V</td> <td>0.087</td> </tr> <tr> <td>690 V</td> <td>0.105</td> </tr> </tbody> </table>	Drive rated voltage	K	200 V	0.037	400 V	0.073	575 V	0.087	690 V	0.105	2	A test is carried out to determine the direction of the flux in the motor which relies on detecting motor saturation. If a change in motor saturation cannot be detected during this test then this trip is initiated. This type of failure is unlikely in most normal motors.	3	During the stationary auto-tuning in RFC-S mode it is necessary to determine the location of the flux axis. If a change in motor saturation cannot be detected during this test then this trip is initiated. This type of failure is unlikely in most normal motors.		
Sub-trip	Reason																				
1	<p>The difference between <i>Ld</i> (05.024) and <i>No-load Lq</i> (05.072) is too small. <math>(Lq-Ld)/Ld</math> must be greater than 0.2. Also <math>Lq-Ld</math> must be greater than <math>K/Full\ Scale\ Current\ Kc</math> (11.061), <math>K</math> is related to the drive voltage rating as given in the table below. It is recommended that the differences are larger than these minimum limits if possible.</p> <table border="1"> <thead> <tr> <th>Drive rated voltage</th> <th>K</th> </tr> </thead> <tbody> <tr> <td>200 V</td> <td>0.037</td> </tr> <tr> <td>400 V</td> <td>0.073</td> </tr> <tr> <td>575 V</td> <td>0.087</td> </tr> <tr> <td>690 V</td> <td>0.105</td> </tr> </tbody> </table>	Drive rated voltage	K	200 V	0.037	400 V	0.073	575 V	0.087	690 V	0.105										
Drive rated voltage	K																				
200 V	0.037																				
400 V	0.073																				
575 V	0.087																				
690 V	0.105																				
2	A test is carried out to determine the direction of the flux in the motor which relies on detecting motor saturation. If a change in motor saturation cannot be detected during this test then this trip is initiated. This type of failure is unlikely in most normal motors.																				
3	During the stationary auto-tuning in RFC-S mode it is necessary to determine the location of the flux axis. If a change in motor saturation cannot be detected during this test then this trip is initiated. This type of failure is unlikely in most normal motors.																				
<b>Inductor Too Hot</b>	<b>The regen inductor has overloaded</b>																				
<b>93</b>	<p>In Regen mode, this trip indicates a regen inductor thermal overload based on the <i>Rated Current</i> (Pr <b>05.007</b>) and the <i>Inductor Thermal Time Constant</i> (Pr <b>04.015</b>). Pr <b>04.019</b> displays the inductor temperature as a percentage of the maximum value. The drive will trip on <i>Inductor Too Hot</i> when Pr <b>04.019</b> gets to 100 %.</p> <p><b>Recommended actions:</b></p> <ul style="list-style-type: none"> <li>Check the load / current through the inductor has not changed.</li> <li>Ensure the <i>Rated Current</i> (Pr <b>05.007</b>) is not zero.</li> </ul>																				

Trip	Diagnosis										
<b>I/O Overload</b>	<b>Digital output overload</b>										
26	<p>The <i>I/O Overload</i> trip indicates that the total current drawn from 24 V user supply or from the digital output has exceeded the limit. A trip is initiated if one or more of the following conditions:</p> <ul style="list-style-type: none"> <li>• Maximum output current from one digital output is 100 mA.</li> <li>• The combined maximum output current from outputs 1 and 2 is 100 mA</li> <li>• The combined maximum output current from output 3 and +24 V output is 100 mA</li> </ul> <p><b>Recommended actions:</b></p> <ul style="list-style-type: none"> <li>• Check total loads on digital outputs</li> <li>• Check control wiring is correct</li> <li>• Check output wiring is undamaged</li> </ul>										
<b>Island</b>	<b>Island condition detected in regen mode</b>										
160	<p>The <i>Island</i> trip indicates that the AC mains is no longer present and the inverter would be on 'islanded' power supply if it continued to operate.</p> <p><b>Recommended actions:</b></p> <ul style="list-style-type: none"> <li>• Check the supply / supply connections to the regen drive</li> </ul>										
<b>Keypad Mode</b>	<b>Keypad has been removed when the drive is receiving the speed reference from the keypad</b>										
34	<p>The <i>Keypad Mode</i> trip indicates that the drive is in keypad mode [<i>Reference Selector</i> (01.014) = 4 or 6] and the keypad has been removed or disconnected from the drive.</p> <p><b>Recommended actions:</b></p> <ul style="list-style-type: none"> <li>• Re-install keypad and reset</li> <li>• Change <i>Reference Selector</i> (01.014) to select the reference from another source</li> </ul>										
<b>Line Sync</b>	<b>Synchronization to the power supply has been lost</b>										
39	<p>The <i>Line Sync</i> trip indicates that the inverter has lost the synchronization with the ac supply in Regen mode.</p> <p><b>Recommended actions:</b></p> <ul style="list-style-type: none"> <li>• Check the supply / supply connections to the regen drive</li> </ul>										
<b>Low Load</b>	<b>The load on the drive has fallen below the low load detection level</b>										
38	<p>When the low load detector is active, the low load condition is detected when the <i>Percentage Load</i> (Pr <b>04.020</b>) falls below the threshold defined by the <i>Low Load Detection Level</i> (Pr <b>04.027</b>).</p> <p><i>Enable Trip On Low Load</i> (Pr <b>04.029</b>) defines the action taken when low load is detected. If <i>Enable Trip On Low Load</i> (Pr <b>04.029</b>) = 0, a Low Load warning is displayed and <i>Low Load Detected Alarm</i> (Pr <b>10.062</b>) = 1. If <i>Enable Trip On Low Load</i> (Pr <b>04.029</b>) = 1 no warning is given, but a Low Load trip is initiated.</p> <p><b>Recommended actions:</b></p> <ul style="list-style-type: none"> <li>• Check the load on the motor has not changed</li> </ul>										
<b>Motor Too Hot</b>	<b>Output current overload timed out (I<sup>2</sup>t)</b>										
20	<p>The <i>Motor Too Hot</i> trip indicates a motor thermal overload based on the output current (Pr <b>05.007</b>) and motor thermal time constant (Pr <b>04.015</b>). Pr <b>04.019</b> displays the motor temperature as a percentage of the maximum value. The drive will trip on <i>Motor Too Hot</i> when Pr <b>04.019</b> gets to 100 %.</p> <p><b>Recommended actions:</b></p> <ul style="list-style-type: none"> <li>• Ensure the load is not jammed / sticking</li> <li>• Check the load on the motor has not changed</li> <li>• If seen during an auto-tune test in RFC-S mode, ensure the motor rated current in Pr <b>05.007</b> is ≤ Heavy duty current rating of the drive</li> <li>• Tune the rated speed parameter (RFC-A mode only)</li> <li>• Check feedback signal for noise</li> <li>• Ensure the motor rated current is not zero</li> </ul>										
<b>Name Plate</b>	<b>Electronic nameplate transfer has failed</b>										
176	<p>The <i>Name Plate</i> trip is initiated if an electronic name plate transfer between the drive and the motor has failed. The exact reason for the trip can be identified from the sub-trip number.</p> <table border="1"> <thead> <tr> <th>Sub-trip</th> <th>Reason</th> </tr> </thead> <tbody> <tr> <td>1</td> <td>Not enough memory space to complete the transfer</td> </tr> <tr> <td>2</td> <td>Communication with encoder failed</td> </tr> <tr> <td>3</td> <td>The transfer has failed</td> </tr> <tr> <td>4</td> <td>The checksum of the stored object has failed</td> </tr> </tbody> </table> <p><b>Recommended actions:</b></p> <ul style="list-style-type: none"> <li>• Ensure that the device encoder memory has at least 128 bytes to store the nameplate data</li> <li>• When writing the motor object (Pr <b>mm.000</b> = 11000), ensure that the device encoder memory has at least 256 bytes to store all the nameplate data.</li> <li>• When transferring between option module and encoder, ensure that the option slot has a feedback option module installed.</li> <li>• Check if the encoder has been initialized in <i>Position Feedback Initialized</i> (03.076).</li> <li>• Verify the encoder wiring.</li> </ul>	Sub-trip	Reason	1	Not enough memory space to complete the transfer	2	Communication with encoder failed	3	The transfer has failed	4	The checksum of the stored object has failed
Sub-trip	Reason										
1	Not enough memory space to complete the transfer										
2	Communication with encoder failed										
3	The transfer has failed										
4	The checksum of the stored object has failed										

Trip	Diagnosis																				
<b>Oht Brake</b>	<b>Braking IGBT over-temperature</b>																				
101	<p>The <i>Oht Brake</i> over-temperature trip indicates that braking IGBT over-temperature has been detected based on software thermal model.</p> <p><b>Recommended actions:</b></p> <ul style="list-style-type: none"> <li>Check braking resistor value is greater than or equal to the minimum resistance value</li> </ul>																				
<b>Oht Control</b>	<b>Control stage over temperature</b>																				
23	<p>This <i>Oht Control</i> trip indicates that a control stage over-temperature has been detected. From the sub-trip 'xyzz', the Thermistor location is identified by 'zz'.</p> <table border="1"> <thead> <tr> <th>Source</th> <th>xx</th> <th>y</th> <th>zz</th> <th>Description</th> </tr> </thead> <tbody> <tr> <td>Control system</td> <td>00</td> <td>0</td> <td>01</td> <td>Control board thermistor 1 over temperature</td> </tr> <tr> <td>Control system</td> <td>00</td> <td>0</td> <td>02</td> <td>Control board thermistor 2 over temperature</td> </tr> <tr> <td>Control system</td> <td>00</td> <td>0</td> <td>03</td> <td>I/O board thermistor over temperature</td> </tr> </tbody> </table> <p><b>Recommended actions:</b></p> <ul style="list-style-type: none"> <li>Check enclosure / drive fans are still functioning correctly</li> <li>Check enclosure ventilation paths</li> <li>Check enclosure door filters</li> <li>Increase ventilation</li> <li>Reduce the drive switching frequency</li> <li>Check ambient temperature</li> </ul>	Source	xx	y	zz	Description	Control system	00	0	01	Control board thermistor 1 over temperature	Control system	00	0	02	Control board thermistor 2 over temperature	Control system	00	0	03	I/O board thermistor over temperature
Source	xx	y	zz	Description																	
Control system	00	0	01	Control board thermistor 1 over temperature																	
Control system	00	0	02	Control board thermistor 2 over temperature																	
Control system	00	0	03	I/O board thermistor over temperature																	
<b>Oht dc bus</b>	<b>DC bus over temperature</b>																				
27	<p>The <i>Oht dc bus</i> trip indicates a DC bus component over temperature based on a software thermal model. The drive includes a thermal protection system to protect the DC bus components within the drive. This includes the effects of the output current and DC bus ripple. The estimated temperature is displayed as a percentage of the trip level in Pr <b>07.035</b>. If this parameter reaches 100 % then an <i>Oht dc bus</i> trip is initiated. The drive will attempt to stop the motor before tripping. If the motor does not stop in 10 seconds the drive trips immediately.</p> <table border="1"> <thead> <tr> <th>Source</th> <th>xx</th> <th>y</th> <th>zz</th> <th>Description</th> </tr> </thead> <tbody> <tr> <td>Control system</td> <td>00</td> <td>2</td> <td>00</td> <td>DC bus thermal model gives trip with sub-trip 0</td> </tr> </tbody> </table> <p><b>Recommended actions:</b></p> <ul style="list-style-type: none"> <li>Check the AC supply voltage balance and levels</li> <li>Check DC bus ripple level</li> <li>Reduce duty cycle</li> <li>Reduce motor load</li> <li>Check the output current stability. If unstable; <ul style="list-style-type: none"> <li>Check the motor map settings with motor nameplate (Pr <b>05.006</b>, Pr <b>05.007</b>, Pr <b>05.008</b>, Pr <b>05.009</b>, Pr <b>05.010</b>, Pr <b>05.011</b>) – (All Modes)</li> <li>Disable slip compensation (Pr <b>05.027</b> = 0) – (Open loop)</li> <li>Disable dynamic V to F operation (Pr <b>05.013</b> = 0) - (Open loop)</li> <li>Select fixed boost (Pr <b>05.014</b> = Fixed) – (Open loop)</li> <li>Select high stability space vector modulation (Pr <b>05.020</b> = 1) – (Open loop)</li> <li>Disconnect the load and complete a rotating auto-tune (Pr <b>05.012</b>) – (RFC-A, RFC-S)</li> <li>Auto-tune the rated speed value (Pr <b>05.016</b> = 1) – (RFC-A, RFC-S)</li> <li>Reduce speed loop gains (Pr <b>03.010</b>, Pr <b>03.011</b>, Pr <b>03.012</b>) – (RFC-A, RFC-S)</li> <li>Add a speed feedback filter value (Pr <b>03.042</b>) – (RFC-A, RFC-S)</li> <li>Add a current demand filter (Pr <b>04.012</b>) – (RFC-A, RFC-S)</li> <li>Check encoder signals for noise with an oscilloscope (RFC-A, RFC-S)</li> <li>Check encoder mechanical coupling - (RFC-A, RFC-S)</li> </ul> </li> </ul>	Source	xx	y	zz	Description	Control system	00	2	00	DC bus thermal model gives trip with sub-trip 0										
Source	xx	y	zz	Description																	
Control system	00	2	00	DC bus thermal model gives trip with sub-trip 0																	
<b>Oht Inverter</b>	<b>Inverter over temperature based on thermal model</b>																				
21	<p>This trip indicates that an IGBT junction over-temperature has been detected based on a software thermal model.</p> <table border="1"> <thead> <tr> <th>Source</th> <th>xx</th> <th>y</th> <th>zz</th> <th>Description</th> </tr> </thead> <tbody> <tr> <td>Control system</td> <td>00</td> <td>1</td> <td>00</td> <td>Inverter thermal model gives {Oht Inverter} trip with sub-trip 0</td> </tr> </tbody> </table> <p><b>Recommended actions:</b></p> <ul style="list-style-type: none"> <li>Reduce the selected drive switching frequency</li> <li>Ensure <i>Auto-switching Frequency Change Disable</i> (05.035) is set to OFF</li> <li>Reduce duty cycle</li> <li>Decrease acceleration / deceleration rates</li> <li>Reduce motor load</li> <li>Check DC bus ripple</li> <li>Ensure all three input phases are present and balanced</li> </ul>	Source	xx	y	zz	Description	Control system	00	1	00	Inverter thermal model gives {Oht Inverter} trip with sub-trip 0										
Source	xx	y	zz	Description																	
Control system	00	1	00	Inverter thermal model gives {Oht Inverter} trip with sub-trip 0																	

Trip	Diagnosis													
<b>Oht Power</b>	<b>Power stage over temperature</b>													
22	This trip indicates that a power stage over-temperature has been detected. From the sub-trip 'xyzz', the Thermistor location is identified by 'zz'.													
	<table border="1"> <thead> <tr> <th>Source</th> <th>xx</th> <th>y</th> <th>zz</th> <th>Description</th> </tr> </thead> <tbody> <tr> <td>Power system</td> <td>01</td> <td>0</td> <td>zz</td> <td>Thermistor location in the drive defined by zz</td> </tr> </tbody> </table>	Source	xx	y	zz	Description	Power system	01	0	zz	Thermistor location in the drive defined by zz			
	Source	xx	y	zz	Description									
Power system	01	0	zz	Thermistor location in the drive defined by zz										
<p><b>Recommended actions:</b></p> <ul style="list-style-type: none"> <li>• Check enclosure / drive fans are still functioning correctly</li> <li>• Force the heatsink fans to run at maximum speed</li> <li>• Check enclosure ventilation paths</li> <li>• Check enclosure door filters</li> <li>• Increase ventilation</li> <li>• Reduce the drive switching frequency</li> <li>• Reduce duty cycle</li> <li>• Decrease acceleration / deceleration rates</li> <li>• Reduce motor load</li> <li>• Check the derating tables and confirm the drive is correctly sized for the application.</li> <li>• Use a drive with larger current / power rating</li> </ul>														
<b>Oht Rectifier</b>	<b>Rectifier over temperature</b>													
102	The <i>Oht Rectifier</i> indicates that a rectifier over-temperature has been detected. The thermistor location can be identified from the sub-trip number.													
	<table border="1"> <thead> <tr> <th>Source</th> <th>xx</th> <th>y</th> <th>zz</th> <th>Description</th> </tr> </thead> <tbody> <tr> <td>Power system</td> <td>Power module number</td> <td>Rectifier number</td> <td>zz</td> <td>Thermistor location defined by zz</td> </tr> </tbody> </table>	Source	xx	y	zz	Description	Power system	Power module number	Rectifier number	zz	Thermistor location defined by zz			
	Source	xx	y	zz	Description									
Power system	Power module number	Rectifier number	zz	Thermistor location defined by zz										
<p><b>Recommend actions:</b></p> <ul style="list-style-type: none"> <li>• Check the motor and motor cable insulation with an insulation tester</li> <li>• Install an output line reactor or sinusoidal filter</li> <li>• Force the heatsink fans to run at maximum speeds by setting Pr <b>06.045</b> = 11</li> <li>• Check enclosure / drive fans are still functioning correctly</li> <li>• Check enclosure ventilation paths</li> <li>• Check enclosure door filters</li> <li>• Increase ventilation</li> <li>• Decrease acceleration / deceleration rates</li> <li>• Reduce duty cycle</li> <li>• Reduce motor load</li> </ul>														
<b>OI ac</b>	<b>Instantaneous output over current detected</b>													
3	The instantaneous drive output current has exceeded above VM_DRIVE_CURRENT_MAX.													
	<table border="1"> <thead> <tr> <th>Source</th> <th>xx</th> <th>y</th> <th>zz</th> <th>Description</th> </tr> </thead> <tbody> <tr> <td>Control system</td> <td>00</td> <td>Rectifier number</td> <td rowspan="2">00</td> <td rowspan="2">Instantaneous over-current trip when the measured a.c. current exceeds VM_DRIVE_CURRENT[MAX].</td> </tr> <tr> <td>Power system</td> <td>Power module number</td> <td>0</td> </tr> </tbody> </table>	Source	xx	y	zz	Description	Control system	00	Rectifier number	00	Instantaneous over-current trip when the measured a.c. current exceeds VM_DRIVE_CURRENT[MAX].	Power system	Power module number	0
	Source	xx	y	zz	Description									
Control system	00	Rectifier number	00	Instantaneous over-current trip when the measured a.c. current exceeds VM_DRIVE_CURRENT[MAX].										
Power system	Power module number	0												
<p><b>Recommended actions:</b></p> <ul style="list-style-type: none"> <li>• Acceleration/deceleration rate is too short</li> <li>• If seen during auto-tune reduce the voltage boost</li> <li>• Check for short circuit on the output cabling</li> <li>• Check integrity of the motor insulation using an insulation tester</li> <li>• Check feedback device wiring</li> <li>• Check feedback device mechanical coupling</li> <li>• Check feedback signals are free from noise</li> <li>• Is motor cable length within limits for the frame size</li> <li>• Reduce the values in the speed loop gain parameters - (Pr <b>03.010</b>, <b>03.011</b>, <b>03.012</b>) or (Pr <b>03.013</b>, <b>03.014</b>, <b>03.015</b>)</li> <li>• Has the phase angle autotune been completed? (RFC-S mode only)</li> <li>• Reduce the values in current loop gain parameters (RFC-A, RFC-S modes only)</li> </ul>														

Trip	Diagnosis										
<b>OI Brake</b>	<b>Braking IGBT over current detected: short circuit protection for the braking IGBT activated</b>										
4	The <i>OI Brake</i> trip indicates that over current has been detected in braking IGBT or braking IGBT protection has been activated.										
	<table border="1"> <thead> <tr> <th>Source</th> <th>xx</th> <th>y</th> <th>zz</th> <th>Description</th> </tr> </thead> <tbody> <tr> <td>Power system</td> <td>Power module number</td> <td>0</td> <td>00</td> <td>Braking IGBT instantaneous over-current trip</td> </tr> </tbody> </table>	Source	xx	y	zz	Description	Power system	Power module number	0	00	Braking IGBT instantaneous over-current trip
	Source	xx	y	zz	Description						
Power system	Power module number	0	00	Braking IGBT instantaneous over-current trip							
<p><b>Recommended actions:</b></p> <ul style="list-style-type: none"> <li>• Check brake resistor wiring</li> <li>• Check braking resistor value is greater than or equal to the minimum resistance value</li> <li>• Check braking resistor insulation</li> </ul>											
<b>OI dc</b>	<b>Power module over current detected from IGBT on state voltage monitoring</b>										
109	The <i>OI dc</i> trip indicates that the short circuit protection for the drive output stage has been activated.										
	<p><b>Recommended actions:</b></p> <ul style="list-style-type: none"> <li>• Disconnect the motor cable at the drive end and check the motor and cable insulation with an insulation tester</li> <li>• Replace the drive</li> </ul>										
<b>OI Snubber</b>	<b>Snubber over-current detected</b>										
92	The <i>OI Snubber</i> trip indicates that an over-current condition has been detected in the rectifier snubber circuit. The reason for the trip can be identified by the sub-trip number.										
	<table border="1"> <thead> <tr> <th>Source</th> <th>xx</th> <th>y</th> <th>zz</th> <th>Description</th> </tr> </thead> <tbody> <tr> <td>Power system</td> <td>Power module number</td> <td>Rectifier number</td> <td>00</td> <td>Rectifier snubber over-current trip detected.</td> </tr> </tbody> </table>	Source	xx	y	zz	Description	Power system	Power module number	Rectifier number	00	Rectifier snubber over-current trip detected.
	Source	xx	y	zz	Description						
Power system	Power module number	Rectifier number	00	Rectifier snubber over-current trip detected.							
<p><b>Recommended actions:</b></p> <ul style="list-style-type: none"> <li>• Ensure the internal EMC Filter is installed</li> <li>• Ensure the motor cable length does not exceed the maximum for selected switching frequency</li> <li>• Check for supply voltage imbalance</li> <li>• Check for supply disturbance such as notching from a DC drive</li> <li>• Check the motor and motor cable insulation with an insulation tester</li> <li>• Install an output line reactor or sinusoidal filter</li> </ul>											
<b>Option Disable</b>	<b>Option module does not acknowledge during drive mode changeover</b>										
215	The <i>Option Disable</i> trip indicates that the option module did not acknowledge notifying the drive that communications with the drive has been stopped during the drive mode changeover with in the allocated time.										
	<p><b>Recommended trip:</b></p> <ul style="list-style-type: none"> <li>• Reset the trip</li> <li>• If the trip persists replace the option module</li> </ul>										
<b>Out Phase Loss</b>	<b>Output phase loss detected</b>										
98	The <i>Out Phase Loss</i> trip indicates that phase loss has been detected at the drive output.										
	<table border="1"> <thead> <tr> <th>Sub-trip</th> <th>Reason</th> </tr> </thead> <tbody> <tr> <td>1</td> <td>U phase detected as disconnected when drive enabled to run.</td> </tr> <tr> <td>2</td> <td>V phase detected as disconnected when drive enabled to run.</td> </tr> <tr> <td>3</td> <td>W phase detected as disconnected when drive enabled to run.</td> </tr> <tr> <td>4</td> <td>Output phase loss detected when the drive is running.</td> </tr> </tbody> </table>	Sub-trip	Reason	1	U phase detected as disconnected when drive enabled to run.	2	V phase detected as disconnected when drive enabled to run.	3	W phase detected as disconnected when drive enabled to run.	4	Output phase loss detected when the drive is running.
	Sub-trip	Reason									
	1	U phase detected as disconnected when drive enabled to run.									
	2	V phase detected as disconnected when drive enabled to run.									
3	W phase detected as disconnected when drive enabled to run.										
4	Output phase loss detected when the drive is running.										
<b>NOTE</b>											
	If Pr <b>05.042</b> = 1 the physical output phases are reversed, and so sub-trip 3 refers to physical output phase V and sub-trip 2 refers to physical output phase W.										
	<p><b>Recommended actions:</b></p> <ul style="list-style-type: none"> <li>• Check motor and drive connections</li> <li>• To disable the trip set <i>Output Phase Loss Detection Enable</i> (06.059) = 0</li> </ul>										
<b>Over Frequency</b>	<b>Output frequency has exceeded the maximum frequency threshold</b>										
222	The <i>Over Frequency</i> trip indicates that the output frequency has exceeded 560 Hz for more than 4 ms.										

Trip	Diagnosis																															
<b>Over Speed</b>	<b>Motor speed has exceeded the over speed threshold</b>																															
7	<p>In open loop mode, if the <i>Output Frequency</i> (05.001) exceeds the threshold set in <i>Over Speed Threshold</i> (03.008) in either direction an <i>Over Speed</i> trip is produced. In RFC-A and RFC-S mode, if the Speed Feedback (03.002) exceeds the <i>Over Speed Threshold</i> in Pr <b>03.008</b> in either direction an <i>Over Speed</i> trip is produced. If Pr <b>03.008</b> is set to 0.0 the threshold is then equal to 1.2 x the value set in Pr <b>01.006</b>.</p> <p>In RFC-A and RFC-S mode, if an SSI encoder is being used and Pr <b>03.047</b> is set to 0 an <i>Over Speed</i> trip will be produced when the encoder passes through the boundary between its maximum position and zero.</p> <p><b>Recommended actions:</b></p> <ul style="list-style-type: none"> <li>Reduce the <i>Speed Controller Proportional Gain</i> (03.010) to reduce the speed overshoot (RFC-A, RFC-S modes only)</li> <li>If an SSI encoder is being used set Pr <b>03.047</b> to 1</li> </ul> <p>The above description relates to a standard Over Speed trip, however in RFC-S mode it is possible to produce an <i>Over Speed.1</i> trip. This is caused if the speed is allowed to exceed the safe level in RFC-S mode with flux weakening when <i>Enable High Speed Mode</i> (05.022) is set to one.</p>																															
<b>Over Volts</b>	<b>DC bus voltage has exceeded the peak level or maximum continuous level for 15 seconds</b>																															
2	<p>The <i>Over Volts</i> trip indicates that the DC bus voltage has exceeded the VM_DC_VOLTAGE[MAX] or VM_DC_VOLTAGE_SET[MAX] for 15 s. The trip threshold varies depending on voltage rating of the drive as shown below.</p> <table border="1"> <thead> <tr> <th>Voltage rating</th> <th>VM_DC_VOLTAGE[MAX]</th> <th>VM_DC_VOLTAGE_SET[MAX]</th> </tr> </thead> <tbody> <tr> <td>200</td> <td>415</td> <td>410</td> </tr> <tr> <td>400</td> <td>830</td> <td>815</td> </tr> <tr> <td>575</td> <td>990</td> <td>970</td> </tr> <tr> <td>690</td> <td>1190</td> <td>1175</td> </tr> </tbody> </table> <p><b>Sub-trip Identification</b></p> <table border="1"> <thead> <tr> <th>Source</th> <th>xx</th> <th>y</th> <th>zz</th> </tr> </thead> <tbody> <tr> <td>Control system</td> <td>00</td> <td>0</td> <td>01: Instantaneous trip when the DC bus voltage exceeds VM_DC_VOLTAGE[MAX].</td> </tr> <tr> <td>Control system</td> <td>00</td> <td>0</td> <td>02: Time delayed trip indicating that the DC bus voltage is above VM_DC_VOLTAGE_SET[MAX].</td> </tr> <tr> <td>Power system</td> <td>Power module number</td> <td>0</td> <td>00: Instantaneous trip when the DC bus voltage exceeds VM_DC_VOLTAGE[MAX].</td> </tr> </tbody> </table> <p><b>Recommended actions:</b></p> <ul style="list-style-type: none"> <li>Increase deceleration ramp (Pr <b>00.004</b>)</li> <li>Decrease the braking resistor value (staying above the minimum value)</li> <li>Check nominal AC supply level</li> <li>Check for supply disturbances which could cause the DC bus to rise</li> <li>Check motor insulation using a insulation tester</li> </ul>	Voltage rating	VM_DC_VOLTAGE[MAX]	VM_DC_VOLTAGE_SET[MAX]	200	415	410	400	830	815	575	990	970	690	1190	1175	Source	xx	y	zz	Control system	00	0	01: Instantaneous trip when the DC bus voltage exceeds VM_DC_VOLTAGE[MAX].	Control system	00	0	02: Time delayed trip indicating that the DC bus voltage is above VM_DC_VOLTAGE_SET[MAX].	Power system	Power module number	0	00: Instantaneous trip when the DC bus voltage exceeds VM_DC_VOLTAGE[MAX].
Voltage rating	VM_DC_VOLTAGE[MAX]	VM_DC_VOLTAGE_SET[MAX]																														
200	415	410																														
400	830	815																														
575	990	970																														
690	1190	1175																														
Source	xx	y	zz																													
Control system	00	0	01: Instantaneous trip when the DC bus voltage exceeds VM_DC_VOLTAGE[MAX].																													
Control system	00	0	02: Time delayed trip indicating that the DC bus voltage is above VM_DC_VOLTAGE_SET[MAX].																													
Power system	Power module number	0	00: Instantaneous trip when the DC bus voltage exceeds VM_DC_VOLTAGE[MAX].																													
<b>Phase Loss</b>	<b>Supply phase loss</b>																															
32	<p>The <i>Phase Loss</i> trip indicates that the drive has detected an input phase loss or large supply imbalance. The drive will attempt to stop the motor before this trip is initiated. If the motor cannot be stopped in 10 seconds the trip occurs immediately. The <i>Phase Loss</i> trip works by monitoring the ripple voltage on the DC bus of the drive, if the DC bus ripple exceeds the threshold, the drive will trip on Phase Loss. Potential causes of the DC bus ripple are input phase loss, Large supply impedance and severe output current instability.</p> <table border="1"> <thead> <tr> <th>Source</th> <th>xx</th> <th>y</th> <th>zz</th> </tr> </thead> <tbody> <tr> <td>Control system</td> <td>00</td> <td>0</td> <td>00: Phase loss detected based on control system feedback. The drive attempts to stop the drive before tripping unless bit 2 of <i>Action On Trip Detection</i> (10.037) is set to one.</td> </tr> <tr> <td>Power system</td> <td rowspan="2">Power module number</td> <td rowspan="2">Rectifier number</td> <td>00: Phase loss has been detected by the rectifier module</td> </tr> <tr> <td>Control system</td> <td>01: Mains loss has been detected by the rectifier module in a multi-power module system, where this must be treated as a phase loss condition to prevent damage to the drive.</td> </tr> </tbody> </table> <p>Input phase loss detection can be disabled when the drive is required to operate from the DC supply or from a single phase supply in <i>Input Phase Loss Detection Mode</i> (06.047).</p> <p><b>Recommended actions:</b></p> <ul style="list-style-type: none"> <li>Check the AC supply voltage balance and level at full load</li> <li>Check the DC bus ripple level with an isolated oscilloscope</li> <li>Check the output current stability</li> <li>Reduce the duty cycle</li> <li>Reduce the motor load</li> <li>Disable the phase loss detection, set Pr <b>06.047</b> to 2.</li> </ul>	Source	xx	y	zz	Control system	00	0	00: Phase loss detected based on control system feedback. The drive attempts to stop the drive before tripping unless bit 2 of <i>Action On Trip Detection</i> (10.037) is set to one.	Power system	Power module number	Rectifier number	00: Phase loss has been detected by the rectifier module	Control system	01: Mains loss has been detected by the rectifier module in a multi-power module system, where this must be treated as a phase loss condition to prevent damage to the drive.																	
Source	xx	y	zz																													
Control system	00	0	00: Phase loss detected based on control system feedback. The drive attempts to stop the drive before tripping unless bit 2 of <i>Action On Trip Detection</i> (10.037) is set to one.																													
Power system	Power module number	Rectifier number	00: Phase loss has been detected by the rectifier module																													
Control system			01: Mains loss has been detected by the rectifier module in a multi-power module system, where this must be treated as a phase loss condition to prevent damage to the drive.																													

Trip	Diagnosis																																																							
<b>Phasing Error</b>	<b>RFC-S mode phasing failure due to incorrect phase angle</b>																																																							
198	<p>The <i>Phasing Error</i> trip indicates that the phase offset angle in Pr <b>03.025</b> (or Pr <b>21.020</b> if the second motor map is being used) is incorrect and the drive is unable to control the motor correctly.</p> <p><b>Recommended actions:</b></p> <ul style="list-style-type: none"> <li>• Check the encoder wiring</li> <li>• Check the encoder signals for noise with an oscilloscope</li> <li>• Check the encoder mechanical coupling</li> <li>• Perform an auto-tune to measure the encoder phase angle or manually enter the correct phase angle into Pr <b>03.025</b></li> <li>• Spurious <i>Phasing Error</i> trips can sometimes be seen in very dynamic applications. This trip can be disabled by setting the over-speed threshold in Pr <b>03.008</b> to a value greater than zero.</li> </ul> <p>If sensorless control is being used this indicates that significant instability has occurred and the motor has accelerated without control.</p> <p><b>Recommended actions:</b></p> <ul style="list-style-type: none"> <li>• Ensure that the motor parameters are set-up correctly.</li> <li>• Reduce the speed controller gains.</li> </ul>																																																							
<b>Power Comms</b>	<b>Communication has been lost / errors detected between power, control and rectifier modules</b>																																																							
90	<p>The <i>Power Comms</i> trip is initiated if there is no communications between power, control or the rectifier module or if excessive communication errors have been detected. The reason for the trip can be identified by the sub-trip number.</p> <table border="1"> <thead> <tr> <th>Source</th> <th>xx</th> <th>y</th> <th>zz</th> </tr> </thead> <tbody> <tr> <td rowspan="2">Control system</td> <td rowspan="2">00</td> <td rowspan="2">0</td> <td>01: No communications between the control system and the power system</td> </tr> <tr> <td>02: Excessive communication errors between the control system and power system</td> </tr> <tr> <td>Power module number</td> <td></td> <td>Rectifier number</td> <td>00: Excessive communications errors detected by the rectifier module</td> </tr> </tbody> </table> <p><b>Recommended actions:</b></p> <ul style="list-style-type: none"> <li>• Hardware fault – Contact the supplier of the drive</li> </ul>	Source	xx	y	zz	Control system	00	0	01: No communications between the control system and the power system	02: Excessive communication errors between the control system and power system	Power module number		Rectifier number	00: Excessive communications errors detected by the rectifier module																																										
Source	xx	y	zz																																																					
Control system	00	0	01: No communications between the control system and the power system																																																					
			02: Excessive communication errors between the control system and power system																																																					
Power module number		Rectifier number	00: Excessive communications errors detected by the rectifier module																																																					
<b>Power Data</b>	<b>Power system configuration data error</b>																																																							
220	<p>The <i>Power Data</i> trip indicates that there is an error in the configuration data stored in the power system.</p> <table border="1"> <thead> <tr> <th>Source</th> <th>xx</th> <th>y</th> <th>zz</th> <th>Description</th> </tr> </thead> <tbody> <tr> <td>Control system</td> <td>00</td> <td>0</td> <td>01</td> <td>No data was obtained from the power board.</td> </tr> <tr> <td>Control system</td> <td>00</td> <td>0</td> <td>02</td> <td>There is no data table in node 1.</td> </tr> <tr> <td>Control system</td> <td>00</td> <td>0</td> <td>03</td> <td>The power system data table is bigger than the space available in the control pod to store it.</td> </tr> <tr> <td>Control system</td> <td>00</td> <td>0</td> <td>04</td> <td>The size of the table given in the table is incorrect.</td> </tr> <tr> <td>Control system</td> <td>00</td> <td>0</td> <td>05</td> <td>Table CRC error.</td> </tr> <tr> <td>Control system</td> <td>00</td> <td>0</td> <td>06</td> <td>The version number of the generator software that produced the table is too low.</td> </tr> <tr> <td>Control system</td> <td>00</td> <td>0</td> <td>07</td> <td>The power data table version does not match the power board hardware identifier</td> </tr> <tr> <td>Power system</td> <td>Power module number</td> <td>0</td> <td>00</td> <td>The power data table used internally by the power module has an error.</td> </tr> <tr> <td>Power system</td> <td>Power module number</td> <td>0</td> <td>01</td> <td>The power data table that is uploaded to the control system on power up has an error.</td> </tr> <tr> <td>Power system</td> <td>Power module number</td> <td>0</td> <td>02</td> <td>The power data table used internally by the power module does not match the hardware identification of the power module.</td> </tr> </tbody> </table> <p><b>Recommended actions:</b></p> <ul style="list-style-type: none"> <li>• Hardware fault – Contact the supplier of the drive</li> </ul>	Source	xx	y	zz	Description	Control system	00	0	01	No data was obtained from the power board.	Control system	00	0	02	There is no data table in node 1.	Control system	00	0	03	The power system data table is bigger than the space available in the control pod to store it.	Control system	00	0	04	The size of the table given in the table is incorrect.	Control system	00	0	05	Table CRC error.	Control system	00	0	06	The version number of the generator software that produced the table is too low.	Control system	00	0	07	The power data table version does not match the power board hardware identifier	Power system	Power module number	0	00	The power data table used internally by the power module has an error.	Power system	Power module number	0	01	The power data table that is uploaded to the control system on power up has an error.	Power system	Power module number	0	02	The power data table used internally by the power module does not match the hardware identification of the power module.
Source	xx	y	zz	Description																																																				
Control system	00	0	01	No data was obtained from the power board.																																																				
Control system	00	0	02	There is no data table in node 1.																																																				
Control system	00	0	03	The power system data table is bigger than the space available in the control pod to store it.																																																				
Control system	00	0	04	The size of the table given in the table is incorrect.																																																				
Control system	00	0	05	Table CRC error.																																																				
Control system	00	0	06	The version number of the generator software that produced the table is too low.																																																				
Control system	00	0	07	The power data table version does not match the power board hardware identifier																																																				
Power system	Power module number	0	00	The power data table used internally by the power module has an error.																																																				
Power system	Power module number	0	01	The power data table that is uploaded to the control system on power up has an error.																																																				
Power system	Power module number	0	02	The power data table used internally by the power module does not match the hardware identification of the power module.																																																				

Trip	Diagnosis													
<b>Power Down Save</b>	<b>Power down save error</b>													
37	<p>The <i>Power Down Save</i> trip indicates that an error has been detected in the power down save parameters saved in non-volatile memory.</p> <p><b>Recommended actions:</b></p> <ul style="list-style-type: none"> <li>Perform a 1001 save in Pr <b>mm.000</b> to ensure that the trip doesn't occur the next time the drive is powered up.</li> </ul>													
<b>PSU</b>	<b>Internal power supply fault</b>													
5	<p>The <i>PSU</i> trip indicates that one or more internal power supply rails are outside limits or overloaded.</p> <table border="1"> <thead> <tr> <th>Source</th> <th>xx</th> <th>y</th> <th>zz</th> <th>Description</th> </tr> </thead> <tbody> <tr> <td>Control system</td> <td>00</td> <td>0</td> <td rowspan="2">00</td> <td rowspan="2">Internal power supply overload.</td> </tr> <tr> <td>Power system</td> <td>Power module number</td> <td>Rectifier number</td> </tr> </tbody> </table> <p><b>Recommended actions:</b></p> <ul style="list-style-type: none"> <li>Remove any option modules and perform a reset</li> <li>Remove encoder connection and perform a reset</li> <li>Hardware fault within the drive – return the drive to the supplier</li> </ul>	Source	xx	y	zz	Description	Control system	00	0	00	Internal power supply overload.	Power system	Power module number	Rectifier number
Source	xx	y	zz	Description										
Control system	00	0	00	Internal power supply overload.										
Power system	Power module number	Rectifier number												
<b>PSU 24V</b>	<b>24V internal power supply overload</b>													
9	<p>The total user load of the drive and option modules has exceeded the internal 24 V power supply limit. The user load consists of the drive digital outputs and main encoder supply.</p> <p><b>Recommended actions:</b></p> <ul style="list-style-type: none"> <li>Reduce the load and reset</li> <li>Provide an external 24 V power supply on control terminal 2</li> <li>Remove all option modules</li> </ul>													
<b>Rating Mismatch</b>	<b>Power stage recognition: Multi module voltage or current rating mismatch</b>													
223	<p>The <i>Rating Mismatch</i> trip indicates that there is a voltage rating or current rating mismatch in a multi-module drive system. This trip is only applicable to modular drives that are connected in parallel. A mixture of power modules with different voltage or current ratings within the same multi-module drive system is not allowed and will cause a <i>Rating Mismatch</i> trip.</p> <p><b>Recommended action:</b></p> <ul style="list-style-type: none"> <li>Ensure that all modules in a multi-modular drive system are of the same frame size and rating (voltage and current)</li> <li>Hardware fault – Contact the supplier of the drive</li> </ul>													
<b>Reserved</b>	<b>Reserved trips</b>													
01 94 -95 103 – 108 170 – 173 228 - 247	<p>These trip numbers are reserved trip numbers for future use. These trips should not be used by the user application programs.</p> <table border="1"> <thead> <tr> <th>Trip Number</th> <th>Description</th> </tr> </thead> <tbody> <tr> <td>01</td> <td>Reserved resettable trip</td> </tr> <tr> <td>94 -95</td> <td>Reserved resettable trip</td> </tr> <tr> <td>103 - 108</td> <td>Reserved resettable trip</td> </tr> <tr> <td>170 - 173</td> <td>Reserved resettable trip</td> </tr> <tr> <td>228 - 247</td> <td>Reserved non-resettable trip</td> </tr> </tbody> </table>	Trip Number	Description	01	Reserved resettable trip	94 -95	Reserved resettable trip	103 - 108	Reserved resettable trip	170 - 173	Reserved resettable trip	228 - 247	Reserved non-resettable trip	
Trip Number	Description													
01	Reserved resettable trip													
94 -95	Reserved resettable trip													
103 - 108	Reserved resettable trip													
170 - 173	Reserved resettable trip													
228 - 247	Reserved non-resettable trip													
<b>Resistance</b>	<b>Measured resistance has exceeded the parameter range</b>													
33	<p>The <i>Resistance</i> trip indicates that the measured stator resistance during an auto-tune test has exceeded the maximum possible value of <i>Stator Resistance</i> (05.017).</p> <p>The stationary auto-tune is initiated using the auto-tune function (Pr <b>05.012</b>) or in open loop vector mode (Pr <b>05.014</b>) on the first run command after power up in mode 4 (Ur_I) or on every run command in modes 0 (Ur_S) or 3 (Ur_Auto). This trip can occur if the motor is very small in comparison to the rating of the drive.</p> <p><b>Recommended actions:</b></p> <ul style="list-style-type: none"> <li>Check the motor cable / connections</li> <li>Check the integrity of the motor stator winding using an insulation tester</li> <li>Check the motor phase to phase resistance at the drive terminals</li> <li>Check the motor phase to phase resistance at the motor terminals</li> <li>Ensure the stator resistance of the motor falls within the range of the drive model</li> <li>Select fixed boost mode (Pr <b>05.014</b> = Fixed) and verify the output current waveforms with an oscilloscope</li> <li>Replace the motor</li> </ul>													

Trip	Diagnosis																																																																																																																																	
<b>Slot4 Different</b>	<b>Ethernet interface in slot 4 has changed (Unidrive HS70 / HS72)</b>																																																																																																																																	
254	The <i>Slot4 Different</i> trip indicates that the Ethernet interface in slot 4 has changed / not found. The reason for the trip can be identified by the sub-trip number.																																																																																																																																	
	<table border="1"> <thead> <tr> <th>Sub-trip</th> <th>Reason</th> </tr> </thead> <tbody> <tr> <td>1</td> <td>No module was installed previously</td> </tr> <tr> <td>2</td> <td>A module with the same identifier is installed, but the set-up menu for this option slot has been changed, and so default parameters have been loaded for this menu.</td> </tr> <tr> <td>3</td> <td>A module with the same identifier is installed, but the applications menu for this option slot has been changed, and so default parameters have been loaded for this menu.</td> </tr> <tr> <td>4</td> <td>A module with the same identifier is installed, but the set-up and applications menu for this option slot have been changed, and so default parameters have been loaded for these menus.</td> </tr> <tr> <td>&gt;99</td> <td>Shows the identifier of the module previously installed.</td> </tr> </tbody> </table>	Sub-trip	Reason	1	No module was installed previously	2	A module with the same identifier is installed, but the set-up menu for this option slot has been changed, and so default parameters have been loaded for this menu.	3	A module with the same identifier is installed, but the applications menu for this option slot has been changed, and so default parameters have been loaded for this menu.	4	A module with the same identifier is installed, but the set-up and applications menu for this option slot have been changed, and so default parameters have been loaded for these menus.	>99	Shows the identifier of the module previously installed.																																																																																																																					
	Sub-trip	Reason																																																																																																																																
	1	No module was installed previously																																																																																																																																
	2	A module with the same identifier is installed, but the set-up menu for this option slot has been changed, and so default parameters have been loaded for this menu.																																																																																																																																
3	A module with the same identifier is installed, but the applications menu for this option slot has been changed, and so default parameters have been loaded for this menu.																																																																																																																																	
4	A module with the same identifier is installed, but the set-up and applications menu for this option slot have been changed, and so default parameters have been loaded for these menus.																																																																																																																																	
>99	Shows the identifier of the module previously installed.																																																																																																																																	
<b>Recommended actions:</b>																																																																																																																																		
	<ul style="list-style-type: none"> <li>To confirm that the parameter changes detected is acceptable, reset the trip and perform a parameter save to ensure that the trip doesn't occur the next time the drive is powered up.</li> <li>If the trip persists - Contact the supplier of the drive.</li> </ul>																																																																																																																																	
<b>Slot4 Error</b>	<b>Ethernet interface in slot 4 has detected a fault (Unidrive HS70 / HS72)</b>																																																																																																																																	
252	The <i>Slot4 Error</i> trip indicates that the Ethernet interface in slot 4 on the drive has detected an error. The reason for the trip can be identified by the sub-trip number.																																																																																																																																	
	<table border="1"> <thead> <tr> <th>Sub-trip</th> <th>Trip string</th> <th>Description</th> </tr> </thead> <tbody> <tr><td>100</td><td>Link Loss</td><td>Network link has been lost</td></tr> <tr><td>101</td><td>E/IP Timeout</td><td>An EtherNet/IP RPI timeout trip has occurred</td></tr> <tr><td>102</td><td>E/IP Read Param</td><td>Invalid read consistency parameter</td></tr> <tr><td>103</td><td>E/IP Write Param</td><td>Invalid write consistency parameter</td></tr> <tr><td>104</td><td>E/IP Fault</td><td>An unexpected EtherNet/IP error has occurred</td></tr> <tr><td>105</td><td>Modbus Timeout</td><td>The Modbus connection has timed out</td></tr> <tr><td>106</td><td>DA-RT Timeout</td><td>DA-RX Rx link has timeout</td></tr> <tr><td>107</td><td>DA-RT Rx Late</td><td>Rx data was received late</td></tr> <tr><td>108</td><td>INIT Switch</td><td></td></tr> <tr><td>109</td><td>INIT PTP</td><td></td></tr> <tr><td>110</td><td>INIT DA-RT</td><td></td></tr> <tr><td>111</td><td>INIT Modbus</td><td></td></tr> <tr><td>112</td><td>INIT SMTP</td><td></td></tr> <tr><td>113</td><td>INIT EtherNet/IP</td><td></td></tr> <tr><td>114</td><td>INIT TCP/IP</td><td></td></tr> <tr><td>115</td><td>Ethernet Failure</td><td></td></tr> <tr><td>200</td><td>Software Fault</td><td>Software Fault</td></tr> <tr><td>201</td><td>BG Overrun</td><td>Background task overrun</td></tr> <tr><td>202</td><td>Firmware Invalid</td><td>Firmware is not compatible for the hardware version</td></tr> <tr><td>203</td><td>Drive Unknown</td><td>Unknown drive type</td></tr> <tr><td>204</td><td>DriveUnsupported</td><td>Unsupported drive type</td></tr> <tr><td>205</td><td>Mode Unknown</td><td>Unknown drive mode</td></tr> <tr><td>206</td><td>Mode Unsupported</td><td>Unsupported drive mode</td></tr> <tr><td>207</td><td>FLASH Error</td><td>Corrupted Non-volatile FLASH</td></tr> <tr><td>208</td><td>Database Init</td><td>Database initialization error</td></tr> <tr><td>209</td><td>File System Init</td><td>File system initialization error</td></tr> <tr><td>210</td><td>Mem Allocation</td><td>Memory allocation error</td></tr> <tr><td>211</td><td>Filesystem Error</td><td>File system error</td></tr> <tr><td>212</td><td>Config Save</td><td>Configuration file save error</td></tr> <tr><td>213</td><td>Over Temperature</td><td>Option module over temperature</td></tr> <tr><td>214</td><td>Drive Timeout</td><td>The drive has not responded within watchdog period</td></tr> <tr><td>215</td><td>eCMP Comms Error</td><td>eCMP communication failure</td></tr> <tr><td>216</td><td>TO eCMP Slot1</td><td>eCMP communication to slot 1 timeout</td></tr> <tr><td>217</td><td>TO eCMP Slot2</td><td>eCMP communication to slot 2 timeout</td></tr> <tr><td>218</td><td>TO eCMP Slot3</td><td>eCMP communication to slot 3 timeout</td></tr> <tr><td>219</td><td>TO eCMP Slot4</td><td>eCMP communication to slot 4 timeout</td></tr> <tr><td>220</td><td>I/O Overload</td><td>Digital output current demand too high</td></tr> <tr><td>221</td><td>Factory Settings</td><td>Missing factory settings</td></tr> <tr><td>222</td><td>Functional Test</td><td>Functional test failure</td></tr> <tr><td>223</td><td>Config Restore</td><td>Configuration file restore error</td></tr> <tr><td>224</td><td>Self Test Error</td><td>Power on self test error</td></tr> <tr><td>225</td><td>Runtime Config</td><td>Runtime configuration error</td></tr> </tbody> </table>	Sub-trip	Trip string	Description	100	Link Loss	Network link has been lost	101	E/IP Timeout	An EtherNet/IP RPI timeout trip has occurred	102	E/IP Read Param	Invalid read consistency parameter	103	E/IP Write Param	Invalid write consistency parameter	104	E/IP Fault	An unexpected EtherNet/IP error has occurred	105	Modbus Timeout	The Modbus connection has timed out	106	DA-RT Timeout	DA-RX Rx link has timeout	107	DA-RT Rx Late	Rx data was received late	108	INIT Switch		109	INIT PTP		110	INIT DA-RT		111	INIT Modbus		112	INIT SMTP		113	INIT EtherNet/IP		114	INIT TCP/IP		115	Ethernet Failure		200	Software Fault	Software Fault	201	BG Overrun	Background task overrun	202	Firmware Invalid	Firmware is not compatible for the hardware version	203	Drive Unknown	Unknown drive type	204	DriveUnsupported	Unsupported drive type	205	Mode Unknown	Unknown drive mode	206	Mode Unsupported	Unsupported drive mode	207	FLASH Error	Corrupted Non-volatile FLASH	208	Database Init	Database initialization error	209	File System Init	File system initialization error	210	Mem Allocation	Memory allocation error	211	Filesystem Error	File system error	212	Config Save	Configuration file save error	213	Over Temperature	Option module over temperature	214	Drive Timeout	The drive has not responded within watchdog period	215	eCMP Comms Error	eCMP communication failure	216	TO eCMP Slot1	eCMP communication to slot 1 timeout	217	TO eCMP Slot2	eCMP communication to slot 2 timeout	218	TO eCMP Slot3	eCMP communication to slot 3 timeout	219	TO eCMP Slot4	eCMP communication to slot 4 timeout	220	I/O Overload	Digital output current demand too high	221	Factory Settings	Missing factory settings	222	Functional Test	Functional test failure	223	Config Restore	Configuration file restore error	224	Self Test Error	Power on self test error	225	Runtime Config	Runtime configuration error
	Sub-trip	Trip string	Description																																																																																																																															
	100	Link Loss	Network link has been lost																																																																																																																															
	101	E/IP Timeout	An EtherNet/IP RPI timeout trip has occurred																																																																																																																															
	102	E/IP Read Param	Invalid read consistency parameter																																																																																																																															
	103	E/IP Write Param	Invalid write consistency parameter																																																																																																																															
	104	E/IP Fault	An unexpected EtherNet/IP error has occurred																																																																																																																															
	105	Modbus Timeout	The Modbus connection has timed out																																																																																																																															
	106	DA-RT Timeout	DA-RX Rx link has timeout																																																																																																																															
	107	DA-RT Rx Late	Rx data was received late																																																																																																																															
	108	INIT Switch																																																																																																																																
	109	INIT PTP																																																																																																																																
	110	INIT DA-RT																																																																																																																																
	111	INIT Modbus																																																																																																																																
	112	INIT SMTP																																																																																																																																
	113	INIT EtherNet/IP																																																																																																																																
	114	INIT TCP/IP																																																																																																																																
	115	Ethernet Failure																																																																																																																																
	200	Software Fault	Software Fault																																																																																																																															
	201	BG Overrun	Background task overrun																																																																																																																															
	202	Firmware Invalid	Firmware is not compatible for the hardware version																																																																																																																															
	203	Drive Unknown	Unknown drive type																																																																																																																															
	204	DriveUnsupported	Unsupported drive type																																																																																																																															
	205	Mode Unknown	Unknown drive mode																																																																																																																															
206	Mode Unsupported	Unsupported drive mode																																																																																																																																
207	FLASH Error	Corrupted Non-volatile FLASH																																																																																																																																
208	Database Init	Database initialization error																																																																																																																																
209	File System Init	File system initialization error																																																																																																																																
210	Mem Allocation	Memory allocation error																																																																																																																																
211	Filesystem Error	File system error																																																																																																																																
212	Config Save	Configuration file save error																																																																																																																																
213	Over Temperature	Option module over temperature																																																																																																																																
214	Drive Timeout	The drive has not responded within watchdog period																																																																																																																																
215	eCMP Comms Error	eCMP communication failure																																																																																																																																
216	TO eCMP Slot1	eCMP communication to slot 1 timeout																																																																																																																																
217	TO eCMP Slot2	eCMP communication to slot 2 timeout																																																																																																																																
218	TO eCMP Slot3	eCMP communication to slot 3 timeout																																																																																																																																
219	TO eCMP Slot4	eCMP communication to slot 4 timeout																																																																																																																																
220	I/O Overload	Digital output current demand too high																																																																																																																																
221	Factory Settings	Missing factory settings																																																																																																																																
222	Functional Test	Functional test failure																																																																																																																																
223	Config Restore	Configuration file restore error																																																																																																																																
224	Self Test Error	Power on self test error																																																																																																																																
225	Runtime Config	Runtime configuration error																																																																																																																																
<b>Recommended actions:</b>																																																																																																																																		
	<ul style="list-style-type: none"> <li>Identify the reason for the trip from the trip string or from sub-trip number and resolve the error.</li> <li>Reset the trip, If the trip persists, Hardware fault - Contact the supplier of the drive.</li> </ul>																																																																																																																																	

Trip	Diagnosis																				
<b>Slot4 HF</b>	<b>Ethernet interface in slot 4 hardware fault (Unidrive HS70 / HS72)</b>																				
250	The <i>Slot4 HF</i> trip indicates that the Ethernet interface in slot 4 on the drive has detected an error. The reason for the error can be identified by the sub-trip number.																				
	<table border="1"> <thead> <tr> <th>Sub-trip</th> <th>Reason</th> </tr> </thead> <tbody> <tr> <td>1</td> <td>The module category cannot be identified</td> </tr> <tr> <td>2</td> <td>All the required customized menu table information has not been supplied or the tables supplied are corrupt</td> </tr> <tr> <td>3</td> <td>There is insufficient memory available to allocate the comms buffers for this module</td> </tr> <tr> <td>4</td> <td>The module has not indicated that it is running correctly during drive power-up</td> </tr> <tr> <td>5</td> <td>Module has been removed after power-up or it has stopped working</td> </tr> <tr> <td>6</td> <td>The module has not indicated that it has stopped accessing drive parameters during a drive mode change</td> </tr> <tr> <td>7</td> <td>The module has failed to acknowledge that a request has been made to reset the drive processor</td> </tr> <tr> <td>8</td> <td>The drive failed to correctly read the menu table from the module during drive power up</td> </tr> <tr> <td>9</td> <td>The drive failed to upload menu tables from the module and timed out (5 s)</td> </tr> </tbody> </table>	Sub-trip	Reason	1	The module category cannot be identified	2	All the required customized menu table information has not been supplied or the tables supplied are corrupt	3	There is insufficient memory available to allocate the comms buffers for this module	4	The module has not indicated that it is running correctly during drive power-up	5	Module has been removed after power-up or it has stopped working	6	The module has not indicated that it has stopped accessing drive parameters during a drive mode change	7	The module has failed to acknowledge that a request has been made to reset the drive processor	8	The drive failed to correctly read the menu table from the module during drive power up	9	The drive failed to upload menu tables from the module and timed out (5 s)
	Sub-trip	Reason																			
	1	The module category cannot be identified																			
	2	All the required customized menu table information has not been supplied or the tables supplied are corrupt																			
	3	There is insufficient memory available to allocate the comms buffers for this module																			
	4	The module has not indicated that it is running correctly during drive power-up																			
	5	Module has been removed after power-up or it has stopped working																			
	6	The module has not indicated that it has stopped accessing drive parameters during a drive mode change																			
	7	The module has failed to acknowledge that a request has been made to reset the drive processor																			
8	The drive failed to correctly read the menu table from the module during drive power up																				
9	The drive failed to upload menu tables from the module and timed out (5 s)																				
<b>Recommended actions:</b>																					
<ul style="list-style-type: none"> <li>Hardware fault - Contact the supplier of the drive.</li> </ul>																					
<b>Slot4 Not Fitted</b>	<b>Ethernet interface in slot 4 has been removed (Unidrive HS70 / HS72)</b>																				
253	The <i>Slot4 Not Fitted</i> trip indicates that the Ethernet interface in slot 4 on the drive has been removed since the last power-up. <b>Recommended actions:</b> <ul style="list-style-type: none"> <li>Hardware fault - Contact the supplier of the drive.</li> </ul>																				
<b>Slot4 Watchdog</b>	<b>Ethernet interface watchdog service error (Unidrive HS70 / HS72)</b>																				
251	The <i>Slot4 Watchdog</i> trip indicates that the Ethernet interface installed in slot 4 has started the option watchdog function and then failed to service the watchdog correctly. <b>Recommended actions:</b> <ul style="list-style-type: none"> <li>Hardware fault - Contact the supplier of the drive.</li> </ul>																				
<b>Slot App Menu</b>	<b>Application menu Customization conflict error</b>																				
216	The <i>Slot App Menu</i> trip indicates that more than one option slot has requested to customize the application menus 18, 19 and 20. The sub-trip number indicates which option slot has been allowed to customize the menus. <b>Recommended actions:</b> <ul style="list-style-type: none"> <li>Ensure that only one of the Application modules is configured to customize the application menus 18, 19 and 20</li> </ul>																				
<b>SlotX Different</b>	<b>Option module in option slot X has changed</b>																				
204 209 214	The <i>SlotX Different</i> trip indicates that the option module in option slot X on the drive is a different type to that installed when parameters were last saved on the drive. The reason for the trip can be identified by the sub-trip number.																				
	<table border="1"> <thead> <tr> <th>Sub-trip</th> <th>Reason</th> </tr> </thead> <tbody> <tr> <td>1</td> <td>No module was installed previously</td> </tr> <tr> <td>2</td> <td>A module with the same identifier is installed, but the set-up menu for this option slot has been changed, and so default parameters have been loaded for this menu.</td> </tr> <tr> <td>3</td> <td>A module with the same identifier is installed, but the applications menu for this option slot has been changed, and so default parameters have been loaded for this menu.</td> </tr> <tr> <td>4</td> <td>A module with the same identifier is installed, but the set-up and applications menu for this option slot have been changed, and so default parameters have been loaded for these menus.</td> </tr> <tr> <td>&gt;99</td> <td>Shows the identifier of the module previously installed.</td> </tr> </tbody> </table>	Sub-trip	Reason	1	No module was installed previously	2	A module with the same identifier is installed, but the set-up menu for this option slot has been changed, and so default parameters have been loaded for this menu.	3	A module with the same identifier is installed, but the applications menu for this option slot has been changed, and so default parameters have been loaded for this menu.	4	A module with the same identifier is installed, but the set-up and applications menu for this option slot have been changed, and so default parameters have been loaded for these menus.	>99	Shows the identifier of the module previously installed.								
	Sub-trip	Reason																			
	1	No module was installed previously																			
	2	A module with the same identifier is installed, but the set-up menu for this option slot has been changed, and so default parameters have been loaded for this menu.																			
	3	A module with the same identifier is installed, but the applications menu for this option slot has been changed, and so default parameters have been loaded for this menu.																			
4	A module with the same identifier is installed, but the set-up and applications menu for this option slot have been changed, and so default parameters have been loaded for these menus.																				
>99	Shows the identifier of the module previously installed.																				
<b>Recommended actions:</b>																					
<ul style="list-style-type: none"> <li>Turn off the power, ensure the correct option modules are installed in the correct option slots and re-apply the power.</li> <li>Confirm that the currently installed option module is correct, ensure option module parameters are set correctly and perform a user save in Pr <b>mm.000</b>.</li> </ul>																					
<b>SlotX Error</b>	<b>Option module in option slot X has detected a fault</b>																				
202 207 212	The <i>SlotX Error</i> trip indicates that the option module in option slot X on the drive has detected an error. The reason for the error can be identified by the sub-trip number. <b>Recommended actions:</b> <ul style="list-style-type: none"> <li>See relevant <i>Option Module User Guide</i> for details of the trip</li> </ul>																				

Trip	Diagnosis																				
<b>SlotX HF</b>	<b>Option module X hardware fault</b>																				
200 205 210	The <i>SlotX HF</i> trip indicates that the option module in option slot X on the drive has indicated a hardware fault. The possible causes of the trip can be identified by the sub-trip number.																				
	<table border="1"> <thead> <tr> <th>Sub-trip</th> <th>Reason</th> </tr> </thead> <tbody> <tr> <td>1</td> <td>The module category cannot be identified</td> </tr> <tr> <td>2</td> <td>All the required customized menu table information has not been supplied or the tables supplied are corrupt</td> </tr> <tr> <td>3</td> <td>There is insufficient memory available to allocate the comms buffers for this module</td> </tr> <tr> <td>4</td> <td>The module has not indicated that it is running correctly during drive power-up</td> </tr> <tr> <td>5</td> <td>Module has been removed after power-up or it has stopped working</td> </tr> <tr> <td>6</td> <td>The module has not indicated that it has stopped accessing drive parameters during a drive mode change</td> </tr> <tr> <td>7</td> <td>The module has failed to acknowledge that a request has been made to reset the drive processor</td> </tr> <tr> <td>8</td> <td>The drive failed to correctly read the menu table from the module during drive power up</td> </tr> <tr> <td>9</td> <td>The drive failed to upload menu tables from the module and timed out (5 s)</td> </tr> </tbody> </table>	Sub-trip	Reason	1	The module category cannot be identified	2	All the required customized menu table information has not been supplied or the tables supplied are corrupt	3	There is insufficient memory available to allocate the comms buffers for this module	4	The module has not indicated that it is running correctly during drive power-up	5	Module has been removed after power-up or it has stopped working	6	The module has not indicated that it has stopped accessing drive parameters during a drive mode change	7	The module has failed to acknowledge that a request has been made to reset the drive processor	8	The drive failed to correctly read the menu table from the module during drive power up	9	The drive failed to upload menu tables from the module and timed out (5 s)
	Sub-trip	Reason																			
	1	The module category cannot be identified																			
	2	All the required customized menu table information has not been supplied or the tables supplied are corrupt																			
	3	There is insufficient memory available to allocate the comms buffers for this module																			
	4	The module has not indicated that it is running correctly during drive power-up																			
	5	Module has been removed after power-up or it has stopped working																			
	6	The module has not indicated that it has stopped accessing drive parameters during a drive mode change																			
	7	The module has failed to acknowledge that a request has been made to reset the drive processor																			
8	The drive failed to correctly read the menu table from the module during drive power up																				
9	The drive failed to upload menu tables from the module and timed out (5 s)																				
<b>Recommended actions:</b>																					
<ul style="list-style-type: none"> <li>• Ensure the option module is installed correctly</li> <li>• Replace the option module</li> <li>• Replace the drive</li> </ul>																					
<b>SlotX Not Fitted</b>	<b>Option module in option slot X has been removed</b>																				
203 208 213	<p>The <i>SlotX Not Fitted</i> trip indicates that the option module in option slot X on the drive has been removed since the last power up.</p> <p><b>Recommended actions:</b></p> <ul style="list-style-type: none"> <li>• Ensure the option module is installed correctly.</li> <li>• Re-install the option module.</li> <li>• To confirm that the removed option module is no longer required perform a save function in Pr <b>mm.000</b>.</li> </ul>																				
<b>SlotX Watchdog</b>	<b>Option module watchdog function service error</b>																				
201 206 211	<p>The <i>SlotX Watchdog</i> trip indicates that the option module installed in Slot X has started the option watchdog function and then failed to service the watchdog correctly.</p> <p><b>Recommended actions:</b></p> <ul style="list-style-type: none"> <li>• Replace the option module</li> </ul>																				
<b>Soft Start</b>	<b>Soft start relay failed to close, soft start monitor failed</b>																				
226	<p>The <i>Soft Start</i> trip indicates that the soft start relay in the drive failed to close or the soft start monitoring circuit has failed.</p> <p><b>Recommended actions:</b></p> <ul style="list-style-type: none"> <li>• Hardware fault – Contact the supplier of the drive</li> </ul>																				
<b>Stored HF</b>	<b>Hardware trip has occurred during last power down</b>																				
221	<p>The <i>Stored HF</i> trip indicates that a hardware trip (HF01 –HF17) has occurred and the drive has been power cycled. The sub-trip number identifies the HF trip i.e. stored HF.17.</p> <p><b>Recommended actions:</b></p> <ul style="list-style-type: none"> <li>• Enter 1299 in Pr <b>mm.000</b> and press reset to clear the trip</li> </ul>																				

Trip	Diagnosis																																																												
<b>Sub-array RAM</b>	<b>RAM allocation error</b>																																																												
227	<p>The Sub-array RAM indicates that an option module, derivative image or user program image has requested more parameter RAM than is allowed. The RAM allocation is checked in order of resulting sub-trip numbers, and so the failure with the highest sub-trip number is given. The sub-trip is calculated as (parameter size) + (parameter type) + sub-array number.</p> <table border="1"> <thead> <tr> <th>Parameter size</th> <th>Value</th> <th>Parameter type</th> <th>Value</th> </tr> </thead> <tbody> <tr> <td>1 bit</td> <td>1000</td> <td>Volatile</td> <td>0</td> </tr> <tr> <td>8 bit</td> <td>2000</td> <td>User save</td> <td>100</td> </tr> <tr> <td>16 bit</td> <td>3000</td> <td>Power-down save</td> <td>200</td> </tr> <tr> <td>32 bit</td> <td>4000</td> <td></td> <td></td> </tr> <tr> <td>64 bit</td> <td>5000</td> <td></td> <td></td> </tr> </tbody> </table> <table border="1"> <thead> <tr> <th>Sub-array</th> <th>Menus</th> <th>Value</th> </tr> </thead> <tbody> <tr> <td>Applications menus</td> <td>18-20</td> <td>1</td> </tr> <tr> <td>Derivative image</td> <td>29</td> <td>2</td> </tr> <tr> <td>User program image</td> <td>30</td> <td>3</td> </tr> <tr> <td>Option slot 1 set-up</td> <td>15</td> <td>4</td> </tr> <tr> <td>Option slot 1 applications</td> <td>25</td> <td>5</td> </tr> <tr> <td>Option slot 2 set-up</td> <td>16</td> <td>6</td> </tr> <tr> <td>Option slot 2 applications</td> <td>26</td> <td>7</td> </tr> <tr> <td>Option slot 3 set-up</td> <td>17</td> <td>8</td> </tr> <tr> <td>Option slot 3 applications</td> <td>27</td> <td>9</td> </tr> <tr> <td>Option slot 4 set-up</td> <td>24</td> <td>10</td> </tr> <tr> <td>Option slot 4 applications</td> <td>28</td> <td>11</td> </tr> </tbody> </table>	Parameter size	Value	Parameter type	Value	1 bit	1000	Volatile	0	8 bit	2000	User save	100	16 bit	3000	Power-down save	200	32 bit	4000			64 bit	5000			Sub-array	Menus	Value	Applications menus	18-20	1	Derivative image	29	2	User program image	30	3	Option slot 1 set-up	15	4	Option slot 1 applications	25	5	Option slot 2 set-up	16	6	Option slot 2 applications	26	7	Option slot 3 set-up	17	8	Option slot 3 applications	27	9	Option slot 4 set-up	24	10	Option slot 4 applications	28	11
Parameter size	Value	Parameter type	Value																																																										
1 bit	1000	Volatile	0																																																										
8 bit	2000	User save	100																																																										
16 bit	3000	Power-down save	200																																																										
32 bit	4000																																																												
64 bit	5000																																																												
Sub-array	Menus	Value																																																											
Applications menus	18-20	1																																																											
Derivative image	29	2																																																											
User program image	30	3																																																											
Option slot 1 set-up	15	4																																																											
Option slot 1 applications	25	5																																																											
Option slot 2 set-up	16	6																																																											
Option slot 2 applications	26	7																																																											
Option slot 3 set-up	17	8																																																											
Option slot 3 applications	27	9																																																											
Option slot 4 set-up	24	10																																																											
Option slot 4 applications	28	11																																																											
<b>Temp Feedback</b>	<b>Internal thermistor has failed</b>																																																												
218	<p>The <i>Temp Feedback</i> trip indicates that an internal thermistor has failed. The thermistor location can be identified by the sub-trip number.</p> <table border="1"> <thead> <tr> <th>Source</th> <th>xx</th> <th>y</th> <th>Zz</th> </tr> </thead> <tbody> <tr> <td>Control PCB</td> <td>00</td> <td>00</td> <td>01: Control PCB thermistor 1 02: Control PCB thermistor 2 03: I/O PCB thermistor</td> </tr> <tr> <td>Power system</td> <td>Power module number</td> <td>0</td> <td>00: Temperature feedback provided via power system comms.</td> </tr> <tr> <td></td> <td></td> <td></td> <td> <table border="1"> <thead> <tr> <th></th> <th>Frame 7</th> <th>Frame 8</th> <th>Frame 9E &amp; 10</th> </tr> </thead> <tbody> <tr> <td>21:</td> <td>Rectifier thermistor</td> <td>Power PCB thermistor 1</td> <td>SMPS thermistor</td> </tr> <tr> <td>22:</td> <td>Power PCB thermistor</td> <td>Power PCB thermistor 2</td> <td>Heat Sink Fan SMPS thermistor</td> </tr> <tr> <td>23:</td> <td>Power PCB thermistor</td> <td>Rectifier thermistor</td> <td>Power PCB thermistor</td> </tr> </tbody> </table> </td> </tr> <tr> <td>Power system</td> <td>Power module number</td> <td>Rectifier number</td> <td>Always zero</td> </tr> </tbody> </table> <p><b>Recommended actions:</b></p> <ul style="list-style-type: none"> <li>• Hardware fault – Contact the supplier of the drive</li> </ul>	Source	xx	y	Zz	Control PCB	00	00	01: Control PCB thermistor 1 02: Control PCB thermistor 2 03: I/O PCB thermistor	Power system	Power module number	0	00: Temperature feedback provided via power system comms.				<table border="1"> <thead> <tr> <th></th> <th>Frame 7</th> <th>Frame 8</th> <th>Frame 9E &amp; 10</th> </tr> </thead> <tbody> <tr> <td>21:</td> <td>Rectifier thermistor</td> <td>Power PCB thermistor 1</td> <td>SMPS thermistor</td> </tr> <tr> <td>22:</td> <td>Power PCB thermistor</td> <td>Power PCB thermistor 2</td> <td>Heat Sink Fan SMPS thermistor</td> </tr> <tr> <td>23:</td> <td>Power PCB thermistor</td> <td>Rectifier thermistor</td> <td>Power PCB thermistor</td> </tr> </tbody> </table>		Frame 7	Frame 8	Frame 9E & 10	21:	Rectifier thermistor	Power PCB thermistor 1	SMPS thermistor	22:	Power PCB thermistor	Power PCB thermistor 2	Heat Sink Fan SMPS thermistor	23:	Power PCB thermistor	Rectifier thermistor	Power PCB thermistor	Power system	Power module number	Rectifier number	Always zero																								
Source	xx	y	Zz																																																										
Control PCB	00	00	01: Control PCB thermistor 1 02: Control PCB thermistor 2 03: I/O PCB thermistor																																																										
Power system	Power module number	0	00: Temperature feedback provided via power system comms.																																																										
			<table border="1"> <thead> <tr> <th></th> <th>Frame 7</th> <th>Frame 8</th> <th>Frame 9E &amp; 10</th> </tr> </thead> <tbody> <tr> <td>21:</td> <td>Rectifier thermistor</td> <td>Power PCB thermistor 1</td> <td>SMPS thermistor</td> </tr> <tr> <td>22:</td> <td>Power PCB thermistor</td> <td>Power PCB thermistor 2</td> <td>Heat Sink Fan SMPS thermistor</td> </tr> <tr> <td>23:</td> <td>Power PCB thermistor</td> <td>Rectifier thermistor</td> <td>Power PCB thermistor</td> </tr> </tbody> </table>		Frame 7	Frame 8	Frame 9E & 10	21:	Rectifier thermistor	Power PCB thermistor 1	SMPS thermistor	22:	Power PCB thermistor	Power PCB thermistor 2	Heat Sink Fan SMPS thermistor	23:	Power PCB thermistor	Rectifier thermistor	Power PCB thermistor																																										
	Frame 7	Frame 8	Frame 9E & 10																																																										
21:	Rectifier thermistor	Power PCB thermistor 1	SMPS thermistor																																																										
22:	Power PCB thermistor	Power PCB thermistor 2	Heat Sink Fan SMPS thermistor																																																										
23:	Power PCB thermistor	Rectifier thermistor	Power PCB thermistor																																																										
Power system	Power module number	Rectifier number	Always zero																																																										
<b>Th Brake Res</b>	<b>Brake resistor over temperature</b>																																																												
10	<p>The <i>Th Brake Res</i> is initiated, If hardware based braking resistor thermal monitoring is connected and the resistor overheats. If the braking resistor is not used then this trip must be disabled with bit 3 of Action <i>On Trip Detection</i> (10.037) to prevent this trip.</p> <p><b>Recommended actions:</b></p> <ul style="list-style-type: none"> <li>• Check brake resistor wiring</li> <li>• Check braking resistor value is greater than or equal to the minimum resistance value</li> <li>• Check braking resistor insulation</li> </ul>																																																												

Trip	Diagnosis						
<b>Th Short Circuit</b>	<b>Motor thermistor short circuit</b>						
25	The <i>Th Short Circuit</i> trip indicates that the motor thermistor connected to the drive is short circuit or low impedance. The location of the trip can be identified by the sub-trip number.						
	<table border="1"> <thead> <tr> <th>Sub-trip</th> <th>Reason</th> </tr> </thead> <tbody> <tr> <td>1</td> <td><i>P1 Thermistor Short Circuit Detect</i> (03.123) = 1 and the resistance of the thermistor connected to the drive P1 position feedback interface is less than 50 <math>\Omega</math>.</td> </tr> <tr> <td>2</td> <td><i>Analog Input 3 Mode</i> (07.015) = 7 and the resistance of the thermistor connected to analog input 3 is less than 50 <math>\Omega</math> (<i>Unidrive HS70 / HS71 only</i>).</td> </tr> </tbody> </table>	Sub-trip	Reason	1	<i>P1 Thermistor Short Circuit Detect</i> (03.123) = 1 and the resistance of the thermistor connected to the drive P1 position feedback interface is less than 50 $\Omega$ .	2	<i>Analog Input 3 Mode</i> (07.015) = 7 and the resistance of the thermistor connected to analog input 3 is less than 50 $\Omega$ ( <i>Unidrive HS70 / HS71 only</i> ).
	Sub-trip	Reason					
	1	<i>P1 Thermistor Short Circuit Detect</i> (03.123) = 1 and the resistance of the thermistor connected to the drive P1 position feedback interface is less than 50 $\Omega$ .					
2	<i>Analog Input 3 Mode</i> (07.015) = 7 and the resistance of the thermistor connected to analog input 3 is less than 50 $\Omega$ ( <i>Unidrive HS70 / HS71 only</i> ).						
<b>Recommended actions:</b> <ul style="list-style-type: none"> <li>• Check thermistor continuity</li> <li>• Replace motor / motor thermistor</li> </ul>							
<b>Thermistor</b>	<b>Motor thermistor over-temperature</b>						
24	The <i>Thermistor</i> trip indicates that the motor thermistor connected to the drive has indicated a motor over temperature. The location of the trip can be identified by the sub-trip number						
	<table border="1"> <thead> <tr> <th>Sub-trip</th> <th>Reason</th> </tr> </thead> <tbody> <tr> <td>1</td> <td>Trip initiated from P1 position feedback interface</td> </tr> <tr> <td>2</td> <td>Trip initiated from analog input 3 (<i>Unidrive HS70 / HS71 only</i>).</td> </tr> </tbody> </table>	Sub-trip	Reason	1	Trip initiated from P1 position feedback interface	2	Trip initiated from analog input 3 ( <i>Unidrive HS70 / HS71 only</i> ).
	Sub-trip	Reason					
	1	Trip initiated from P1 position feedback interface					
2	Trip initiated from analog input 3 ( <i>Unidrive HS70 / HS71 only</i> ).						
<b>Recommended actions:</b> <ul style="list-style-type: none"> <li>• Check motor temperature</li> <li>• Check thermistor continuity</li> </ul>							
<b>Undefined</b>	<b>Drive has tripped and the cause of the trip is Undefined</b>						
110	The <i>Undefined</i> trip indicates that the power system has generated but did not identify the trip the power system. The cause of the trip is unknown. <b>Recommended actions:</b> <ul style="list-style-type: none"> <li>• Hardware fault – return the drive to the supplier</li> </ul>						
<b>User 24V</b>	<b>User 24 V supply is not present on control terminals (1,2)</b>						
91	A <i>User 24 V</i> trip is initiated, if <i>User Supply Select</i> (Pr <b>06.072</b> ) is set to 1 or <i>Low Under Voltage Threshold Select</i> (06.067) = 1 and no user 24 V supply is present on control terminals 1 and 2. <b>Recommended actions:</b> <ul style="list-style-type: none"> <li>• Ensure the user 24 V supply is present on control terminals 1 (0 V) and 2 (24 V)</li> </ul>						

Trip	Diagnosis		
<b>User Program</b>	<b>On board user program error</b>		
<b>249</b>	The <i>User Program</i> trip indicates that an error has been detected in the onboard user program image. The reason for the trip can be identified by the sub-trip number.		
	Sub-trip	Reason	Comments
	1	Divide by zero	
	2	Undefined trip	
	3	Attempted fast parameter access set-up with non-existent parameter	
	4	Attempted access to non-existent parameter	
	5	Attempted write to read-only parameter	
	6	Attempted and over-range write	
	7	Attempted read from write-only parameter	
	30	The image has failed because either its CRC is incorrect, or there are less than 6 bytes in	Occurs when the drive powers-up or the image is programmed. The image tasks will not run
	31	The image requires more RAM for heap and stack than can be provided by the drive.	As 30
	32	The image requires an OS function call that is higher than the maximum allowed	As 30
	33	The ID code within the image is not valid	As 30
	34	The derivative image has been changed for an image with a different derivative number.	As 30
	40	The timed task has not completed in time and has been suspended	
	41	Undefined function called, i.e. a function in the host system vector table that has not been	As 40
	51	Core menu customization table CRC check failed	As 30
	52	Customized menu table CRC check failed	As 30
	53	Customized menu table changed	Occurs when the drive powers-up or the image is programmed and the table has changed. Defaults are loaded for the derivative menu and the trip will keep occurring until drive parameters are saved.
	61	The option module installed in slot 1 is not allowed with the derivative image	As 30
	62	The option module installed in slot 2 is not allowed with the derivative image	As 30
	63	The option module installed in slot 3 is not allowed with the derivative image	As 30
	64	The option module installed in slot 4 is not allowed with the derivative image	As 30
	70	An option module that is required by the derivative image is not installed in any slot.	As 30
	71	An option module specifically required to be installed in slot 1 not present	As 30
	72	An option module specifically required to be installed in slot 2 not present	As 30
	73	An option module specifically required to be installed in slot 3 not present	As 30
74	An option module specifically required to be installed in slot 4 not present	As 30	
80	Image is not compatible with the control board	Initiated from within the image code	
81	Image is not compatible with the control board serial number	As 80	

Trip	Diagnosis
<b>User Prog Trip</b>	<b>Trip generated by an onboard user program</b>
<b>96</b>	This trip can be initiated from within an onboard user program using a function call which defines the sub-trip number. <b>Recommended actions:</b> <ul style="list-style-type: none"> <li>• Check the user program</li> </ul>
<b>User Save</b>	<b>User Save error / not completed</b>
<b>36</b>	The <i>User Save</i> trip indicates that an error has been detected in the user save parameters saved in non-volatile memory. For example, following a user save command, if the power to the drive was removed when the user parameters were being saved. <b>Recommended actions:</b> <ul style="list-style-type: none"> <li>• Perform a user save in Pr <b>mm.000</b> to ensure that the trip doesn't occur the next time the drive is powered up.</li> <li>• Ensure that the drive has enough time to complete the save before removing the power to the drive.</li> </ul>
<b>User Trip</b>	<b>User generated trip</b>
<b>40 -89 112 -159</b>	These trips are not generated by the drive and are to be used by the user to trip the drive through an application program. <b>Recommended actions:</b> <ul style="list-style-type: none"> <li>• Check the user program</li> </ul>
<b>Volts Range</b>	<b>Supply voltage out of range detected in Regen mode</b>
<b>169</b>	The <i>Volts Range</i> trip is initiated, if the <i>Regen Minimum Voltage</i> (03.026) is set to a non-zero value and the supply voltage is outside the range defined by <i>Regen Maximum Voltage</i> (03.027) and <i>Regen Minimum Voltage</i> (03.026) for more than 100 ms. <b>Recommended actions:</b> <ul style="list-style-type: none"> <li>• Ensure the supply voltage is operating within the drive specification.</li> <li>• Ensure Pr <b>03.026</b> and Pr <b>03.027</b> are set correctly</li> <li>• Check the supply voltage waveform using an oscilloscope</li> <li>• Reduce the level of supply disturbance</li> <li>• Set <i>Maximum Voltage</i> (03.027) to zero to disable the trip.</li> </ul>
<b>Watchdog</b>	<b>Control word watchdog has timed out</b>
<b>30</b>	The <i>Watchdog</i> trip indicates that the control word has been enabled and has timed out <b>Recommended actions:</b>

**Table 12-5 Serial communications look up table**

No	Trip	No	Trip	No	Trip
1	Reserved 001	92	OI Snubber	198	Phasing Error
2	Over Volts	93	Inductor Too Hot	199	Destination
3	OI ac	94 - 95	Reserved 93 -95	200	Slot1 HF
4	OI Brake	96	User Prog Trip	201	Slot1 Watchdog
5	PSU	97	Data Changing	202	Slot1 Error
6	External Trip	98	Out Phase Loss	203	Slot1 Not installed
7	Over Speed	99	CAM	204	Slot1 Different
8	Inductance	100	Reset	205	Slot2 HF
9	PSU24	101	OHT Brake	206	Slot2 Watchdog
10	Th Brake Res	102	OHT Rectifier	207	Slot2 Error
11	Autotune 1	103 - 108	Reserved 103 - 108	208	Slot2 Not installed
12	Autotune 2	109	OI dc	209	Slot2 Different
13	Autotune 3	110	Undefined	210	Slot3 HF
14	Autotune 4	111	Configuration	211	Slot3 Watchdog
15	Autotune 5	112 - 167	User Trip 112 - 167	212	Slot3 Error
16	Autotune 6	168	Frequency Range	213	Slot3 Not installed
17	Autotune 7	169	Voltage Range	214	Slot3 Different
18	Autotune Stopped	170 - 173	Reserved 170 - 173	215	Option Disable
19	Brake R Too Hot	174	Card Slot	216	Slot App Menu
20	Motor Too Hot	175	Card Product	217	App Menu Changed
21	OHT Inverter	176	Name Plate	218	Temp Feedback
22	OHT Power	177	Card Boot	219	An Output Calib
23	OHT Control	178	Card Busy	220	Power Data
24	Thermistor	179	Card Data Exists	221	Stored HF
25	Th Short Circuit	180	Card Option	222	Over Frequency
26	I/O Overload	181	Card Read Only	223	Rating Mismatch
27	OHT dc bus	182	Card Error	224	Drive Size
28	An Input Loss 1	183	Card No Data	225	Current Offset
29	An Input Loss 2	184	Card Full	226	Soft Start
30	Watchdog	185	Card Access	227	Sub-array RAM
31	EEPROM Fail	186	Card Rating	228 - 247	Reserved 228 - 247
32	Phase Loss	187	Card Drive Mode	248	Derivative Image
33	Resistance	188	Card Compare	249	User Program
34	Keypad Mode	189	Encoder 1	250	Slot4 HF
35	Control Word	190	Encoder 2	251	Slot4 Watchdog
36	User Save	191	Encoder 3	252	Slot4 Error
37	Power Down Save	192	Encoder 4	253	Slot4 Not installed
38	Low Load	193	Encoder 5	254	Slot4 Different
39	Line Sync	194	Encoder 6	255	Reset Logs
40 -89	User Trip 40 - 89	195	Encoder 7		
90	Power Comms	196	Encoder 8		
91	User 24V	197	Encoder 9		

The trips can be grouped into the following categories. It should be noted that a trip can only occur when the drive is not tripped or is already tripped but with a trip with a lower priority number.

**Table 12-6 Trip categories**

Priority	Category	Trips	Comments
1	Internal faults	HF01, HF02, HF03, HF04, HF05, HF06, HF07, HF08, HF09, HF10, HF11, HF12, HF13, HF14, HF15, HF16, HF17, HF18, HF19, HF20	These indicate internal problems and cannot be reset. All drive features are inactive after any of these trips occur. If an KI-Keypad is installed it will show the trip, but the keypad will not function.
1	Stored HF trip	{Stored HF}	This trip cannot be cleared unless 1299 is entered into <i>Parameter (mm.000)</i> and a reset is initiated.
2	Non-resettable trips	Trip numbers 218 to 247, {Slot1 HF}, {Slot2 HF}, {Slot3 HF} or {Slot4 HF}	These trips cannot be reset.
3	Volatile memory failure	{EEPROM Fail}	This can only be reset if Parameter <b>mm.000</b> is set to 1233 or 1244, or if <i>Load Defaults (11.043)</i> is set to a non-zero value.
4	NV Media Card trips	Trip numbers 174, 175 and 177 to 188	These trips are priority 5 during power-up.
4	Internal 24V and position feedback interface power supply	{PSU 24} and {Encoder 1}	These trips can override {Encoder 2} to {Encoder 6} trips.
5	Trips with extended reset times	{OI ac}, {OI Brake}, and OI dc}	These trips cannot be reset until 10 s after the trip was initiated.
5	Phase loss and d.c. link power circuit protection	{Phase Loss} and {Oht dc bus}	The drive will attempt to stop the motor before tripping if a {Phase Loss}.000 trip occurs unless this feature has been disabled (see <i>Action On Trip Detection (10.037)</i> ). The drive will always attempt to stop the motor before tripping if an {Oht dc bus} occurs.
5	Standard trips	All other trips	

## 12.5 Internal / Hardware trips

Trips {HF01} to {HF20} are internal faults that do not have trip numbers. If one of these trips occurs, the main drive processor has detected an irrecoverable error. All drive functions are stopped and the trip message will be displayed on the drive keypad. If a non permanent trip occurs this may be reset by power cycling the drive. On power up after it has been power cycled the drive will trip on Stored HF. Enter 1299 in **mm.000** to clear the Stored HF trip.

## 12.6 Alarm indications

In any mode, an alarm is an indication given on the display by alternating the alarm string with the drive status string on the first row and showing the alarm symbol in the last character in the first row. If an action is not taken to eliminate any alarm except "Auto Tune and Limit Switch" the drive may eventually trip. Alarms are not displayed when a parameter is being edited, but the user will still see the alarm character on the upper row.

**Table 12-7 Alarm indications**

Alarm string	Description
<b>Brake Resistor</b>	Brake resistor overload. <i>Braking Resistor Thermal Accumulator</i> (10.039) in the drive has reached 75.0 % of the value at which the drive will trip.
<b>Motor Overload</b>	<i>Motor Protection Accumulator</i> (04.019) in the drive has reached 75.0 % of the value at which the drive will trip and the load on the drive is >100 %.
<b>Ind Overload</b>	Regen inductor overload. <i>Inductor Protection Accumulator</i> (04.019) in the drive has reached 75.0 % of the value at which the drive will trip and the load on the drive is >100 %.
<b>Drive Overload</b>	Drive over temperature. <i>Percentage Of Drive Thermal Trip Level</i> (07.036) in the drive is greater than 90 %.
<b>Auto Tune</b>	The autotune procedure has been initialized and an autotune in progress.
<b>Limit Switch</b>	Limit switch active. Indicates that a limit switch is active and that is causing the motor to be stopped.

## 12.7 Status indications

**Table 12-8 Status indications**

Upper row string	Description	Drive output stage
<b>Inhibit</b>	The drive is inhibited and cannot be run. The SAFE TORQUE OFF signal is not applied to SAFE TORQUE OFF terminals or Pr <b>06.015</b> is set to 0	Disabled
<b>Ready</b>	The drive is ready to run. The drive enable is active, but the drive inverter is not active because the final drive run is not active	Disabled
<b>Stop</b>	The drive is stopped / holding zero speed.	Enabled
<b>Run</b>	The drive is active and running	Enabled
<b>Scan</b>	The drive is enabled in Regen mode and is trying to synchronize to the supply	Enabled
<b>Supply Loss</b>	Supply loss condition has been detected	Enabled
<b>Deceleration</b>	The motor is being decelerated to zero speed / frequency because the final drive run has been deactivated.	Enabled
<b>dc injection</b>	The drive is applying dc injection braking	Enabled
<b>Position</b>	Positioning / position control is active during an orientation stop	Enabled
<b>Trip</b>	The drive has tripped and no longer controlling the motor. The trip code appears in the lower display	Disabled
<b>Active</b>	The regen unit is enabled and synchronized to the supply	Enabled
<b>Under Voltage</b>	The drive is in the under voltage state either in low voltage or high voltage mode	Disabled

**Table 12-9 Option module and NV Media Card and other status indications at power-up**

First row string	Second row string	Status
<b>Booting</b>	<b>Parameters</b>	Parameters are being loaded
Drive parameters are being loaded from a NV Media Card		
<b>Booting</b>	<b>User Program</b>	User program being loaded
User program is being loaded from a NV Media Card to the drive		
<b>Booting</b>	<b>Option Program</b>	User program being loaded
User program is being loaded from a NV Media Card to the option module in slot X		
<b>Writing To</b>	<b>NV Card</b>	Data being written to NV Media Card
Data is being written to a NV Media Card to ensure that its copy of the drive parameters is correct because the drive is in Auto or Boot mode		
<b>Waiting For</b>	<b>Power System</b>	Waiting for power stage
The drive is waiting for the processor in the power stage to respond after power-up		
<b>Waiting For</b>	<b>Options</b>	Waiting for an option module
The drive is waiting for the Options Modules to respond after power-up		
<b>Uploading From</b>	<b>Options</b>	Loading parameter database
At power-up it may be necessary to update the parameter database held by the drive because an option module has changed or because an applications module has requested changes to the parameter structure. This may involve data transfer between the drive an option modules. During this period 'Uploading From Options' is displayed		

## 12.8 Programming error indications

Following are the error message displayed on the drive keypad when an error occurs during programming of drive firmware.

**Table 12-10 Programming error indications**

Error String	Reason	Solution
<b>Error 1</b>	There is not enough drive memory requested by all the option modules.	Power down drive and remove some of the option modules until the message disappears.
<b>Error 2</b>	At least one option module did not acknowledge the reset request.	Power cycle drive
<b>Error 3</b>	The boot loader failed to erase the processor flash	Power cycle drive and try again. If problem persists, return drive
<b>Error 4</b>	The boot loader failed to program the processor flash	Power cycle drive and try again. If problem persists, return drive
<b>Error 5</b>	One option module did not initialize correctly. Option module did not set Ready to Run flag.	Remove faulty option module.

## 12.9 Displaying the trip history

The drive retains a log of the last ten trips that have occurred. *Trip 0* (10.020) to *Trip 9* (10.029) store the most recent 10 trips that have occurred where *Trip 0* (10.020) is the most recent and *Trip 9* (10.029) is the oldest. When a new trip occurs it is written to *Trip 0* (10.020) and all the other trips move down the log, with oldest being lost. The date and time when each trip occurs are also stored in the date and time log, i.e. *Trip 0 Date* (10.041) to *Trip 9 Time* (10.060). The date and time are taken from *Date* (06.016) and *Time* (06.017). Some trips have sub-trip numbers which give more detail about the reason for the trip. If a trip has a sub-trip number its value is stored in the sub-trip log, i.e. *Trip 0 Sub-trip Number* (10.070) to *Trip 9 Sub-trip Number* (10.079). If the trip does not have a sub-trip number then zero is stored in the sub-trip log.

If any parameter between Pr **10.020** and Pr **10.029** inclusive is read by serial communication, then the trip number in Table 12-5 is the value transmitted.

### NOTE

The trip logs can be reset by writing a value of 255 in Pr **10.038**.

## 12.10 Behaviour of the drive when tripped

If the drive trips, the output of the drive is disabled so the load coasts to a stop. If any trip occurs the following read only parameters are frozen until the trip is cleared. This is to help in diagnose the cause of the trip.

Parameter	Description
<b>01.001</b>	Frequency / speed reference
<b>01.002</b>	Pre-skip filter reference
<b>01.003</b>	Pre-ramp reference
<b>02.001</b>	Post-ramp reference
<b>03.001</b>	Frequency slaving demand / Final speed ref
<b>03.002</b>	Speed feedback
<b>03.003</b>	Speed error
<b>03.004</b>	Speed controller output
<b>04.001</b>	Current magnitude
<b>04.002</b>	Active current
<b>04.017</b>	Reactive current
<b>05.001</b>	Output frequency
<b>05.002</b>	Output voltage
<b>05.003</b>	Power
<b>05.005</b>	DC bus voltage
<b>07.001</b>	Analog input 1*
<b>07.002</b>	Analog input 2*
<b>07.003</b>	Analog input 3*

\*On Unidrive HS70 / HS71 only.

If the parameters are not required to be frozen then this can be disabled by setting bit 4 of Pr **10.037**.

## 13 UL listing information

### 13.1 General

Drive sizes 3, 4, 5 and 6 have been assessed to meet both UL and cUL requirements.

UL listings can be viewed online at [www.UL.com](http://www.UL.com). The UL file number is E171230.

### 13.2 Mounting

Drives can be installed in the following configurations as detailed in the Drive Installation Guide:

- Standard or surface mounted.
- Through-hole mounted.
- Tile mounted. The drive is mounted sideways with the side panel against the mounting surface. This configuration reduces the overall depth of the installation. A Tile mounting kit is available. See UL listed accessories.
- Bookcase mounted. Drives are mounted side by side with no space between them. This configuration minimises the overall width of the installation.

### 13.3 Environment

Drives are able to meet the following UL/ NEMA environmental ratings:

- Type 1. The drive must either be installed with a UL Type 1 kit or be installed in a Type 1 enclosure.
- Type 12. The drive must be installed in a Type 12 enclosure.
- If the drive is through-hole mounted inside a Type 12 enclosure, then both the High-IP insert and the Type 12 sealing kit must be installed in order to provide protection against ingress of dirt and water. See the Drive Installation Guide for more details.
- The remote keypad is rated to both UL Type 1 and UL Type 12
- Drives must be installed in a pollution degree 2 environment or better.

### 13.4 Electrical installation

The following precautions must be observed when installing drives to UL requirements:

- Drives are rated for use at 40 °C, 50 °C and 55 °C ambient temperature except where indicated otherwise in the *Drive Installation Guide*.
- For operation up to 50 °C, the temperature rating of the power cables must be at least 60 °C.
- For operation up to 55 °C, the temperature rating of the power cables must be at least 75 °C.
- If the drive control stage is powered from an external power supply (+24 V), the power supply must be listed or recognized to UL class 2 with appropriate fusing, see section 3.2.1 *24 Vdc supply* on page 16.
- Ground connections must use UL listed closed loop (ring) terminals.

### 13.5 UL listed accessories

The following options are UL listed

- |                        |                             |
|------------------------|-----------------------------|
| • KI-Keypad            | • Tile mounting kit         |
| • KI-Keypad RTC        | • Metal conduit entry plate |
| • KI-Keypad Advanced   | • Type 12 sealing kit       |
| • SI-PROFIBUS          | • SD card kit               |
| • SI-DeviceNet         | • UL Type 1 kit             |
| • SI-CANopen           |                             |
| • SI-Applications Plus |                             |
| • SI-Register          |                             |

### 13.6 Motor overload protection

- The drives are installed with solid state motor overload protection.
- The default overload protection level is less than 150 % of full load rated current for open loop operation.
- The default overload protection level is less than 175 % of full load rated current for closed loop vector or servo mode operation.
- In order for the motor protection to work correctly, the motor rated current must be entered into Pr **00.046** or Pr **05.007**
- The protection level may be adjusted below 150 % if required. See section 7.3 *Current limits* on page 86.

### 13.7 Motor overspeed protection

The drive is installed with solid state motor overspeed protection. However, this feature does not provide the level of protection provided by an independent, high-integrity overspeed protection device.

### 13.8 Thermal memory retention

Drives incorporate thermal memory retention that complies fully with the requirements of UL508C.

The drive is provided with motor load and speed sensitive overload protection with thermal memory retention that complies with the US National Electrical Code (NFPA 70) clause 430.126, and Underwriters Laboratories Standard UL508C, clause 20.1.11 (a). The purpose of this protection is to protect both drive and motor from dangerous overheating in the event of repeated overload or failure to start, even if the power to the drive is removed between overload events.

For a full explanation of the thermal protection system, refer to section 7.4 *Motor thermal protection* on page 86.

In order to comply with UL requirements for thermal memory retention it is necessary to set the *Thermal Protection Mode* (Pr 04.016) to zero; and the *Low Speed Protection Mode* (Pr 04.025) must be set to 1 if the drive is operated in Heavy Duty mode.

Alternatively, an external thermal sensor or switch may be used as a means of motor and drive overload protection that complies with the requirements of UL508C, clause 20.1.11 (b). This protection method is particularly recommended where independent forced cooling of the motor is used, because of the risk of overheating if the cooling is lost.

#### External thermal sensor

The drive is provided with a means to accept and act upon a signal from a thermal sensor or switch imbedded in the motor or from an external protective relay. Refer to section 3.2.3 *Unidrive HS70 / HS71 control terminal specification* on page 18.

### 13.9 Electrical Ratings

- Drives are listed for connection to an AC supply capable of delivering no more than 100 kA symmetrical amperes at 264 Vac rms maximum (200 V drives), 528 Vac rms maximum (400 V drives) or 600 Vac rms maximum (575 V and 690 V drives).
- Drives are listed for Over Voltage CAT III.
- Power, current, fuse and circuit breaker ratings are given in the *Drive Installation Guide*.
- Unless indicated otherwise in the *Drive Installation Guide*, fuses may be any UL listed Class J or CC with a voltage rating of at least 600 VAC.
- Unless indicated otherwise in the *Drive Installation Guide*, circuit breakers may be any UL listed type, category control number: DIVQ or DIVQ7, with a voltage rating of at least 600 Vac.

### 13.10 cUL requirements for 575 V frame size 7 and 8

For size 7 and 8 575Vac models only (07500440, 07500550, 08500630, 08500860), the following must be adhered to in order to comply with cUL approval requirements:

Transient surge suppression shall be installed on the line side of this equipment and shall be rated 575 Vac (phase to ground), 575 Vac (phase to phase), suitable for overvoltage category III, and shall provide protection for a rated impulse withstand voltage peak of 6 kV and a clamping voltage of maximum 2400 V.

# Index

## Symbols

+10V user output.....	18
+24V external input.....	18, 20, 22, 23
+24V user output.....	19, 22

## Numerics

0V common.....	18, 22
----------------	--------

## A

Acceleration.....	50, 66, 67, 68, 69
Accuracy.....	192
Acoustic noise.....	192
Advanced menus.....	35
Advanced parameters.....	96
Alarm.....	223
Alarm Indications.....	223
Altitude.....	191
Analog input 2.....	19
Analog input 3.....	19
Analog output 1.....	19
Analog output 2.....	19
Autotune.....	78

## B

Basic requirements.....	61
-------------------------	----

## C

Cautions.....	6
Control connections.....	16
Control terminal specification.....	18, 22
Cooling method.....	191
Current limit.....	50
Current limits.....	86
Current loop gains.....	84

## D

Deceleration.....	53, 66, 67, 68, 69
Defaults (restoring parameter).....	37
Destination parameter.....	16, 21
Diagnostics.....	194
Digital I/O 1.....	20, 22
Digital I/O 2.....	20, 22
Digital I/O 3.....	20
Digital Input 1.....	20, 22
Digital Input 2.....	20, 22
Digital Input 3.....	20
Dimensions (overall).....	192
Display.....	32
Display messages.....	36
Drive enable.....	20, 23
Drive features.....	11

## E

Electromagnetic compatibility (EMC).....	193
EMC filters (optional external).....	193
Emission.....	193
Encoder connections.....	23
Encoder feedback limits.....	87
Encoder types.....	24

## F

Field weakening (constant power) operation.....	87
Fixed V/F mode.....	10

## G

Getting Started.....	32
----------------------	----

## H

High speed operation.....	87
Humidity.....	191

## I

IP Rating (Ingress protection).....	191
-------------------------------------	-----

## K

Keypad operation.....	32
-----------------------	----

## L

Line reactors.....	191
--------------------	-----

## M

Maximum speed / frequency.....	88, 192
Menu 0.....	35
Menu 01 - Frequency / speed reference.....	108
Menu 02 - Ramps.....	112
Menu 03 - Slave frequency, speed feedback and speed control.....	115
Menu 04 - Torque and current control.....	126
Menu 05 - Motor control.....	130
Menu 06 - Sequencer and clock.....	137
Menu 07 - Analog I/O.....	141
Menu 08 - Digital I/O.....	144
Menu 09 - Programmable logic, motorized pot and binary sum.....	150
Menu 10 - Status and trips.....	156
Menu 11 - General drive set-up.....	158
Menu 12 - Threshold detectors and variable selectors.....	160
Menu 13 - Standard motion controller.....	168
Menu 14 - User PID controller.....	172
Menu 18 - Application menu 1.....	177
Menu 19 - Application menu 2.....	177
Menu 20 - Application menu 3.....	177
Menu 21 - Second motor parameters.....	178
Menu 22 - Additional Menu 0 set-up.....	180
Menu structure.....	34
Minimum connections to get the motor running in any operating mode.....	62
Mode parameter.....	16, 21
Monitoring.....	52
Motor (running the motor).....	61
Motor number of poles.....	77
Motor parameters.....	58
Motor rated current.....	77
Motor rated current (maximum).....	86
Motor rated frequency.....	77
Motor rated power factor.....	77
Motor rated speed.....	77
Motor rated voltage.....	77
Motor requirements.....	191
Motor thermal protection.....	86

<b>N</b>		<b>S</b>	
NEMA rating .....	191, 192	SAFE TORQUE OFF .....	29
Notes .....	6	SAFE TORQUE OFF data .....	192
NV media card operation .....	89	SAFE TORQUE OFF/drive enable .....	20, 23
<b>O</b>		Safety Information .....	6
Onboard PLC .....	94	Saving parameters .....	37
Open loop mode .....	10	Serial comms lead .....	16
Open loop vector mode .....	10	Serial communications connections .....	15
Operating mode (changing) .....	37, 61	Serial communications look-up table .....	196
Operating modes .....	10	Serial communications port isolation .....	15
Operating-mode selection .....	59	Single line descriptions .....	41
Optimization .....	77	Speed feedback .....	61
Option Module .....	176	Speed limits .....	48
Options .....	13	Speed loop gains .....	82, 84, 85
Output frequency .....	192	Speed range .....	192
<b>P</b>		Speed reference selection .....	50
Parameter access level .....	37	Speed-loop PID gains .....	51
Parameter ranges .....	99	Start up time .....	192
Parameter security .....	37	Starts per hour .....	192
Parameter x.00 .....	50	Status .....	223
Position feedback .....	61	Status Indications .....	223
Position feedback module category parameters .....	176	Status information .....	60
Precision reference Analog input 1 .....	18	Storage .....	191
Product information .....	8	Supply requirements .....	191
<b>Q</b>		Switching frequency .....	87, 88
Quadratic V/F mode .....	10	<b>T</b>	
Quick start commissioning .....	70	Technical data .....	191
Quick start commissioning / Start-up .....	66	Temperature .....	191
Quick start connections .....	61	Trip .....	194
<b>R</b>		Trip History .....	224
Ramps .....	50	Trip Indications .....	194
Ratings .....	8	<b>U</b>	
Reactor current ratings .....	191	UL Listing Information .....	225
Relay contacts .....	20, 23	User Security .....	37
Resolution .....	192	<b>V</b>	
RFC-A mode .....	10	Vibration .....	192
RFC-S mode .....	10	Voltage boost .....	51
		Voltage mode .....	78, 79
		<b>W</b>	
		Warnings .....	6



**0478-0231-01**